

T-CBN SERIES

TUNGALOY

Negative relief ang., G class,
80° rhombic CBN insert with corner angle 70°.

INSERT

2QP-GNGA

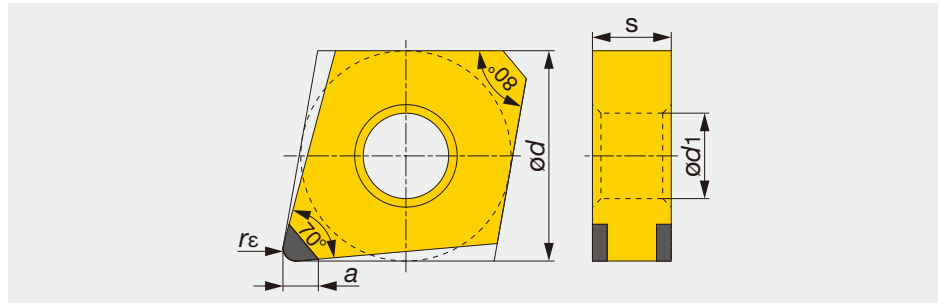
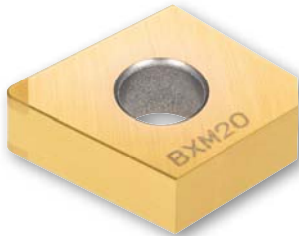

Rhombic, 70°

Designation	Stocked grades				I.C.dia ϕd	Thick- ness s	Hole dia $\phi d1$	Corner radius r_ϵ	CBN Length a
	Coated	Non-coated							
	BXM20	BX360	BX470	BX930					
2QP-GNGA120404	✓	✓			12.7	4.76	5.16	0.4	2.3
2QP-GNGA120408	✓	✓	✓	✓	12.7	4.76	5.16	0.8	2.2
2QP-GNGA120412	✓	✓	✓	✓	12.7	4.76	5.16	1.2	2.4

✓ : Stocked items

STANDARD CUTTING CONDITIONS

ISO	Workpiece materials	Grade	Cutting speed V_c (m/min)	Depth of cut a_p (mm)	Feed f (mm/rev)
K	Grey cast iron	BX930 BX470	300 - 1200	0.05 - 0.50	0.05 - 0.30
	Ductile cast iron	BX930	100 - 500	0.05 - 0.50	0.05 - 0.30
H	Hardened steel	BXM20	70 - 220	0.05 - 0.30	0.05 - 0.25
	Sintered metal	BX470	80 - 300	0.05 - 0.50	0.05 - 0.25