

MODEL IN SCALE 1:2

Pipes for tubing and drill

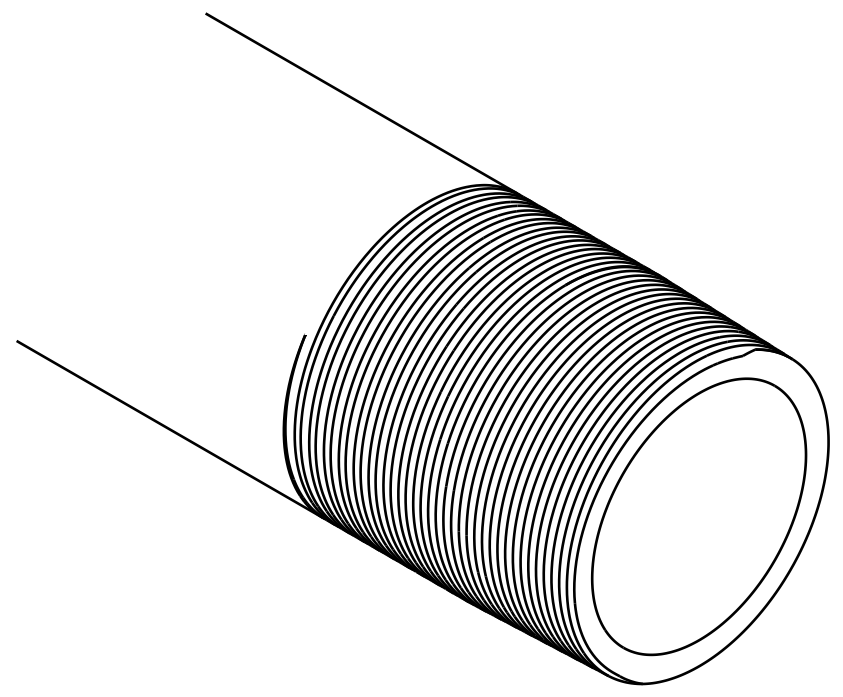

Couplings

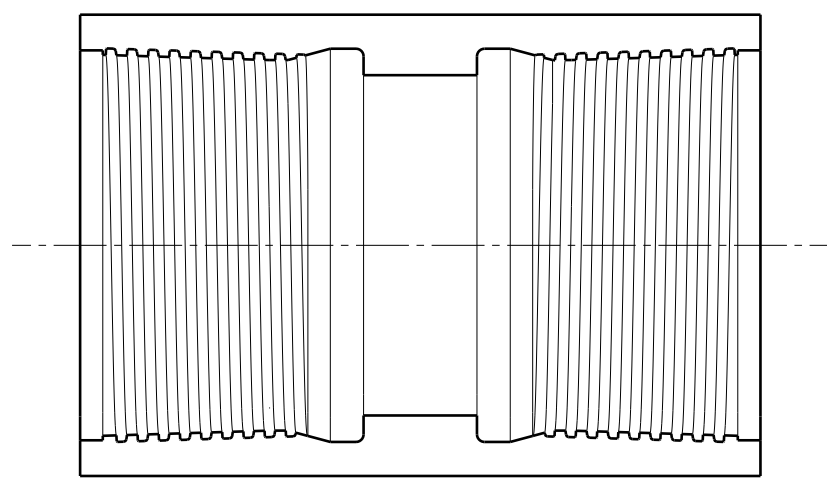
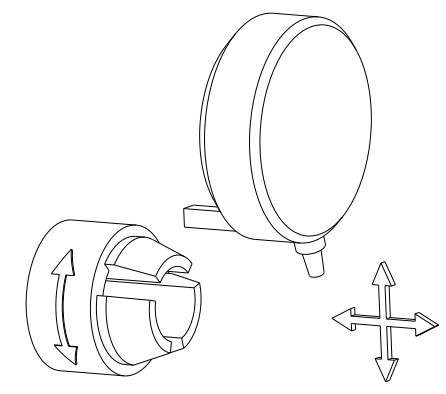
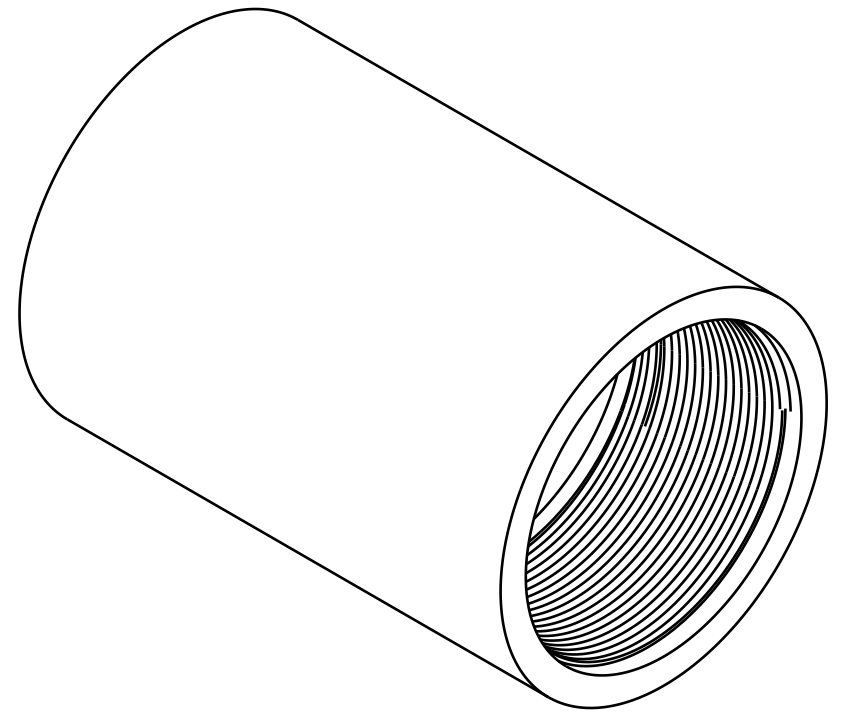

WORK : PIPE

WORKPIECE MATERIAL :
Carbon / Chromium steel

MACHINE : Horizontal Lathe

Unspecified Tolerances	Draw		Customer: TUNGALOY	Japan	
	Design		Designation: LAYOUT PIPE		
Dim.s:	Check		Process		Page 1
	Appr.		Concept	Layout.	Rev. No. 1
Angles:	Scale		-		Reg.No. 62317/1
	© 2019 Tungaloy Corporation - Copyrights Notice		FL-40032545		A3L

MODEL IN SCALE 1:2 TOOLS IN SCALE 1:2

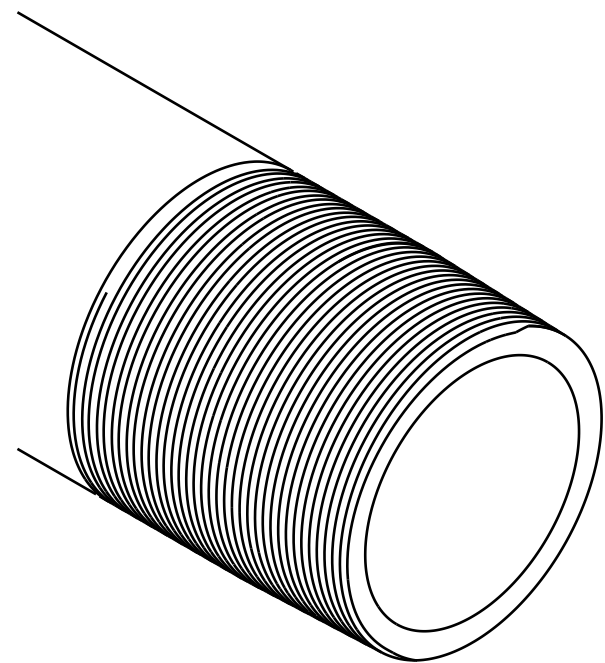
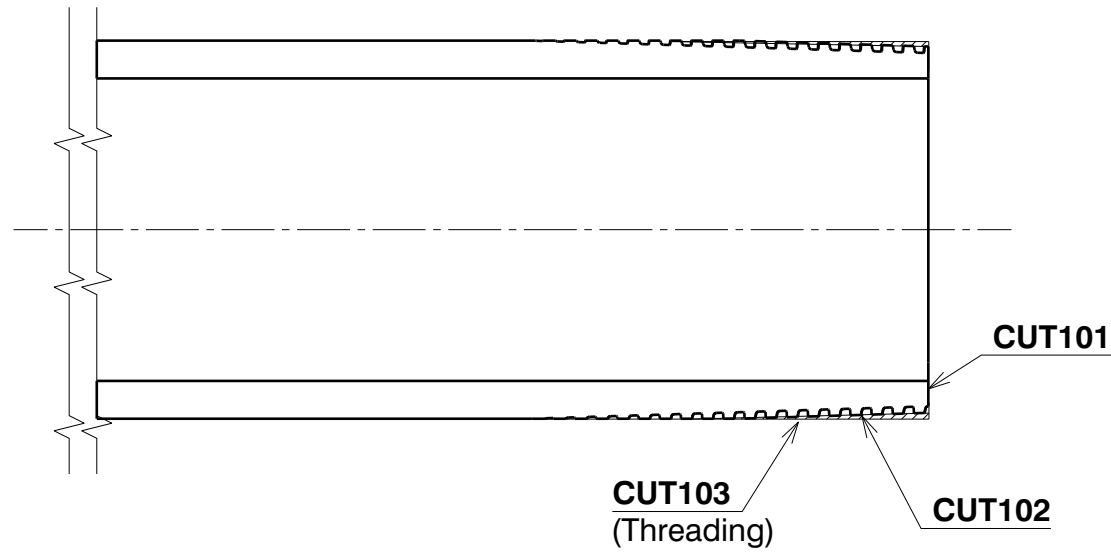

TungCap TungTurn-Jet

CUT 101/102
O.D. Turning Rough
Face Turning Rough
 C6PCLNR45065-12-CHP
 CNMG120412-THS T9215

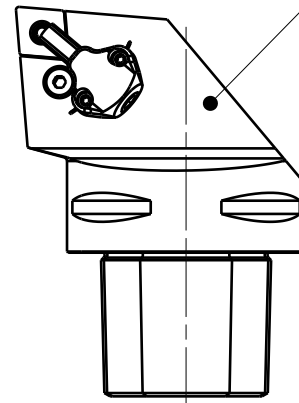

TungCap TurnTenFeed

CUT 102
O.D. Turning Rough
 C6ASHR251-J
 PPXOR2525M11-HD
 POMG110612-MNW T9215

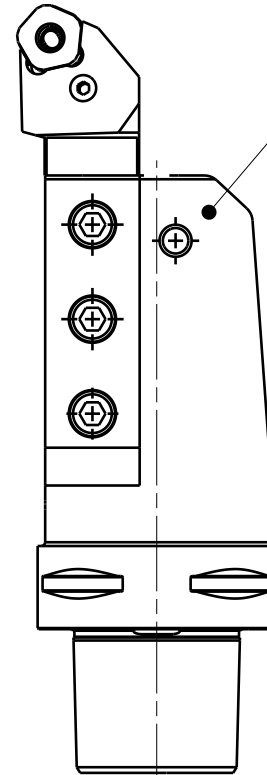

TungCap Fix Rturn

CUT 101/102
O.D. Turning Rough
Face Turning Rough
 C6ASHR251-J
 SRGCR2525M12-6F
 RCMT1204M0-6RS T9215

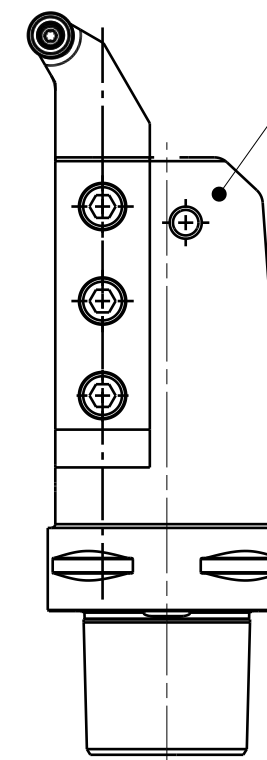

TungCap Chaser insert

CUT 103
O.D. Threading Rough
 C6-JT-RF35L65 (special)
 CNGA-5B75-3E AH725

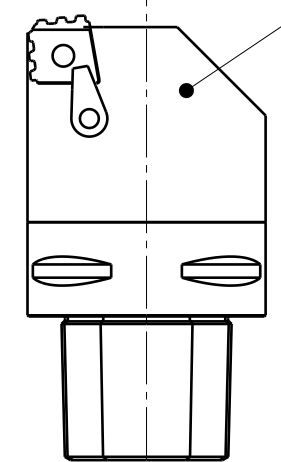

TungCap Chaser insert

CUT 102/103
O.D. Turning & Threading Rough
 C8-JT-RF45L80 (special)
 RCMT2006M0-RS T9225
 CR-5B75-4E AH725

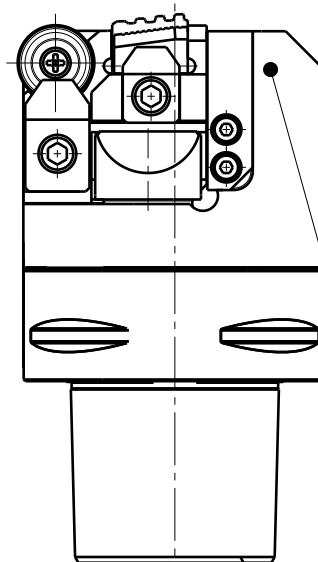

TungCap Chaser insert

CUT 103
O.D. Threading Rough
 C6-JT-RF35L65 (special)
 CR-5B75-4E AH725

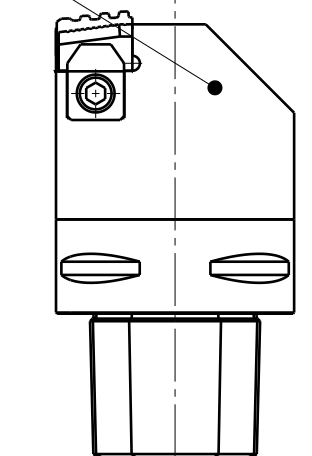

Lathe: O.D turning & Threading

Unspecified Tolerances	Draw		Customer: TUNGALOY	Japan	
	Design				
Dim.s:	Check		Process	Layout.	Page 1 Of 1
	Appr.				
Angles:	Scale		-	-	Reg. No. 62317/1

MODEL IN SCALE 1:2 TOOLS IN SCALE 1:2

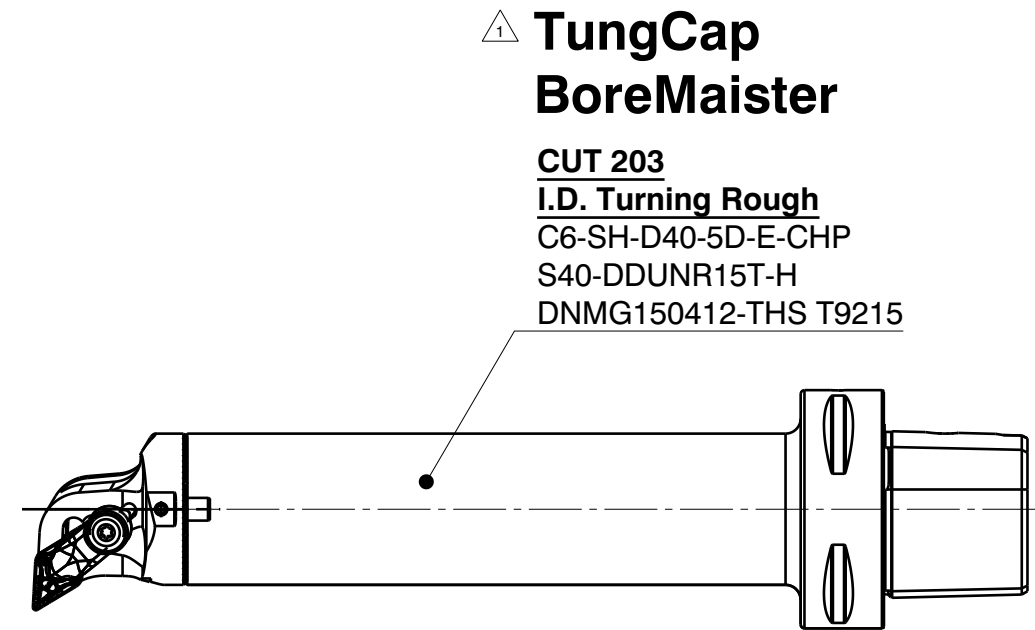
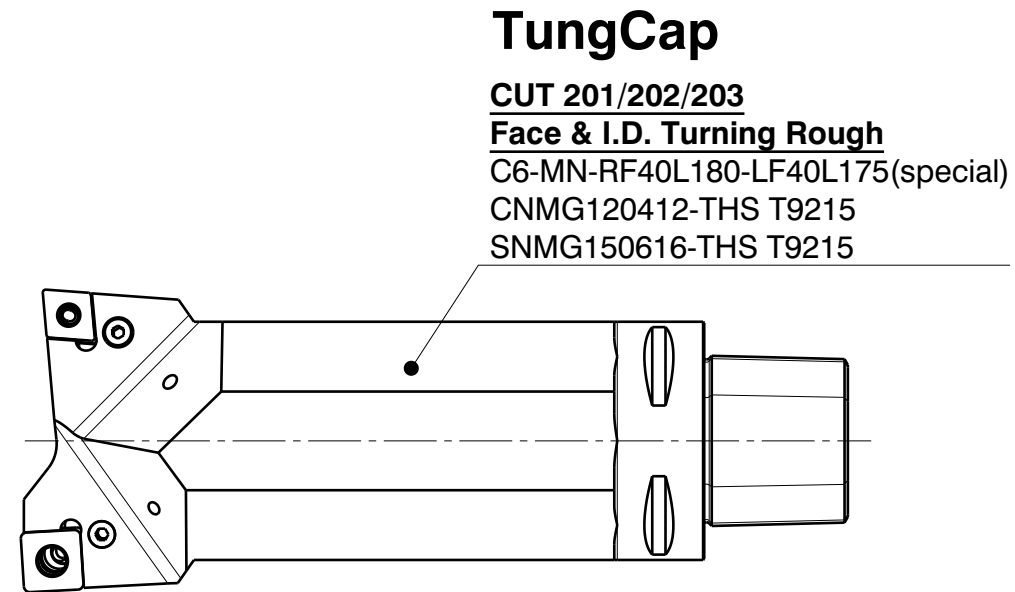
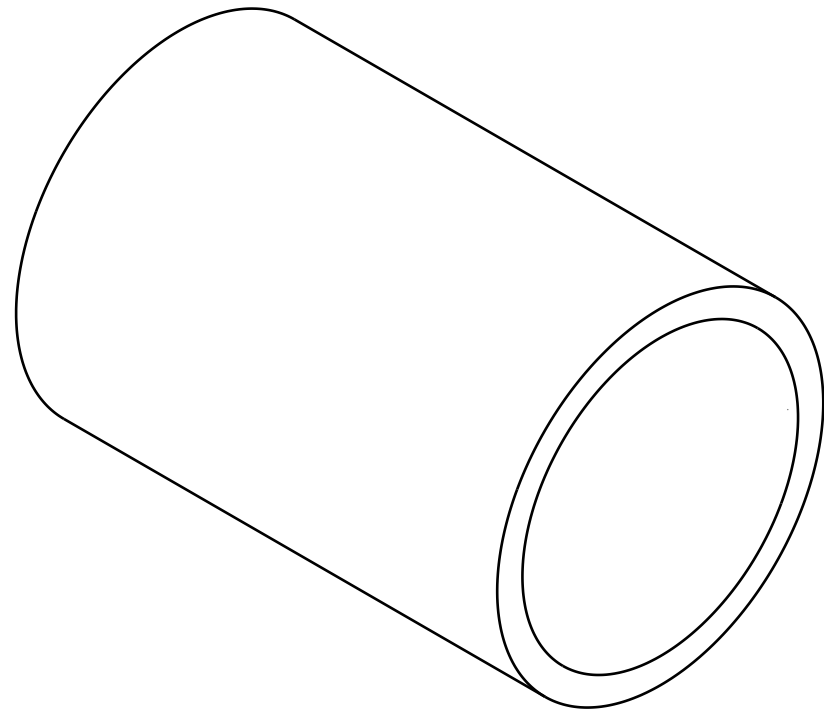
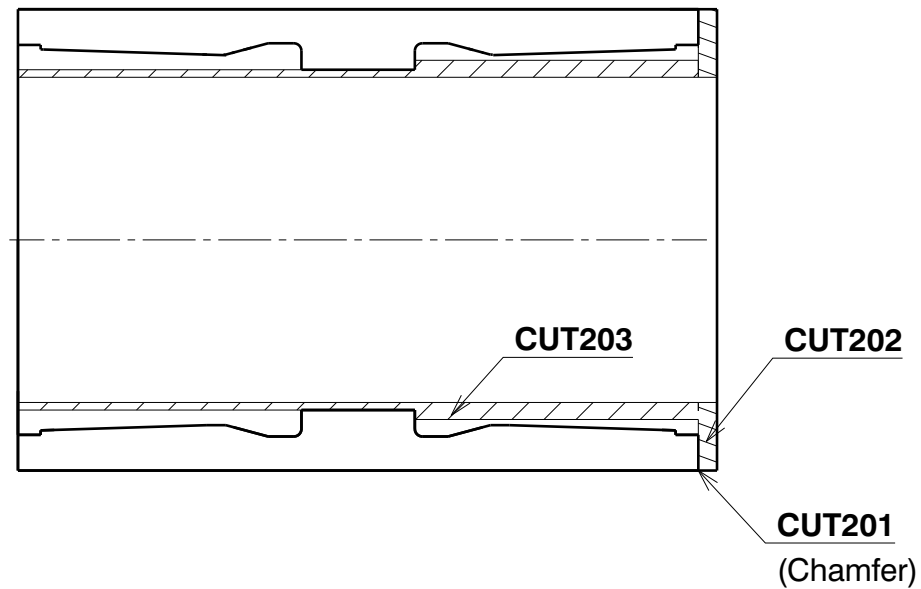

Lathe: Parting-off

Face & I.D Rough turning

Unspecified Tolerances	Draw		Customer: TUNGALOY	Japan	
	Design		Designation: LAYOUT OP200-PIPE		
Dim.s:	Check		Process		Page 1
	Appr.		Concept	Layout.	Of 1
Angles:	Scale		-		Rev. No. 1
	© 2019 Tungaloy Corporation - Copyrights Notice		FL-40032545		Reg. No. 62317/1

MODEL IN SCALE 1:2 TOOLS IN SCALE 1:2

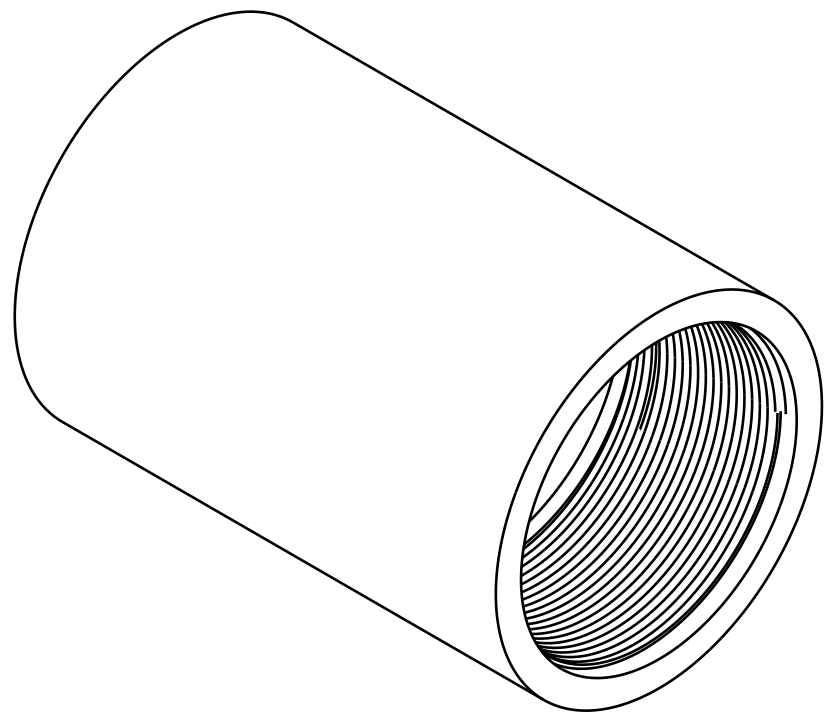
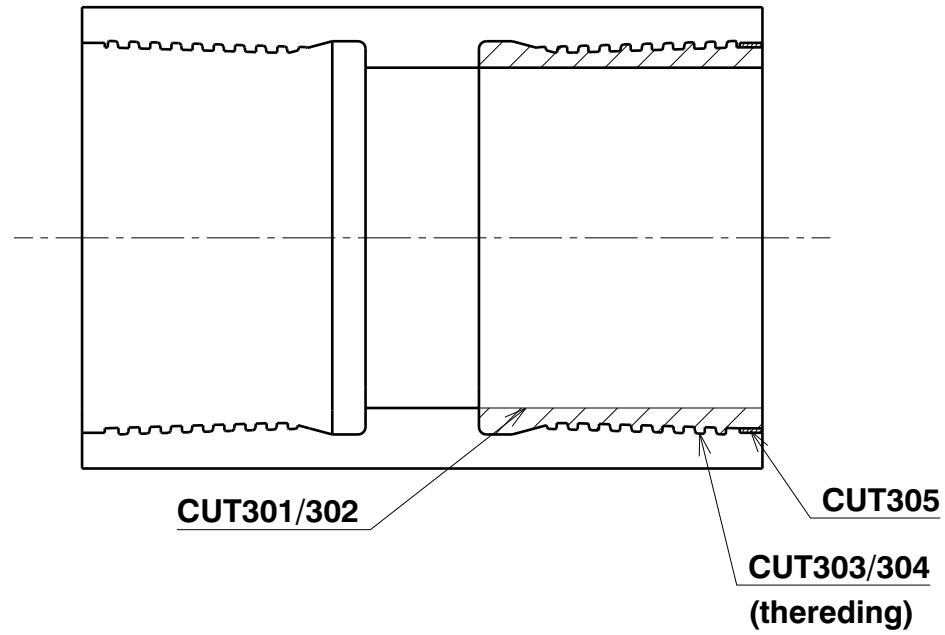

I.D turning & Threading

TungCap Chaser insert

CUT 301/302/303
I.D. Turning Rough/Finish & Threading Rough
 C6-MN-RF40L140-LF40L140(special)
 DNMG150612-THS T9215
 CR-5B75-3I AH725

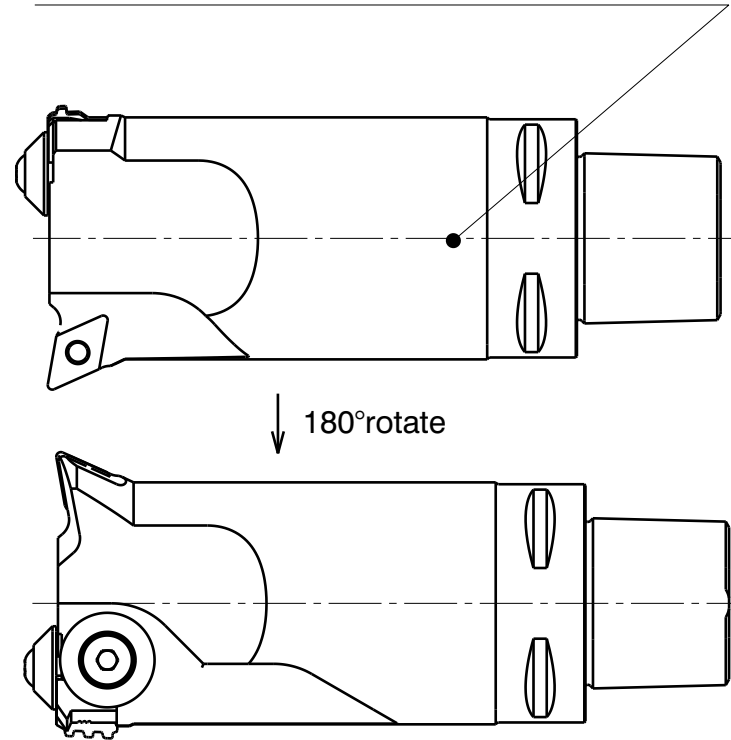

TungCap Chaser insert

CUT 304/305
I.D. Turning Finish & I.D. Threading Finish
 C6-MN-RF38L140-LF40L140(special)
 SCMT120408-PS T9215
 CR-5B75-3I AH725

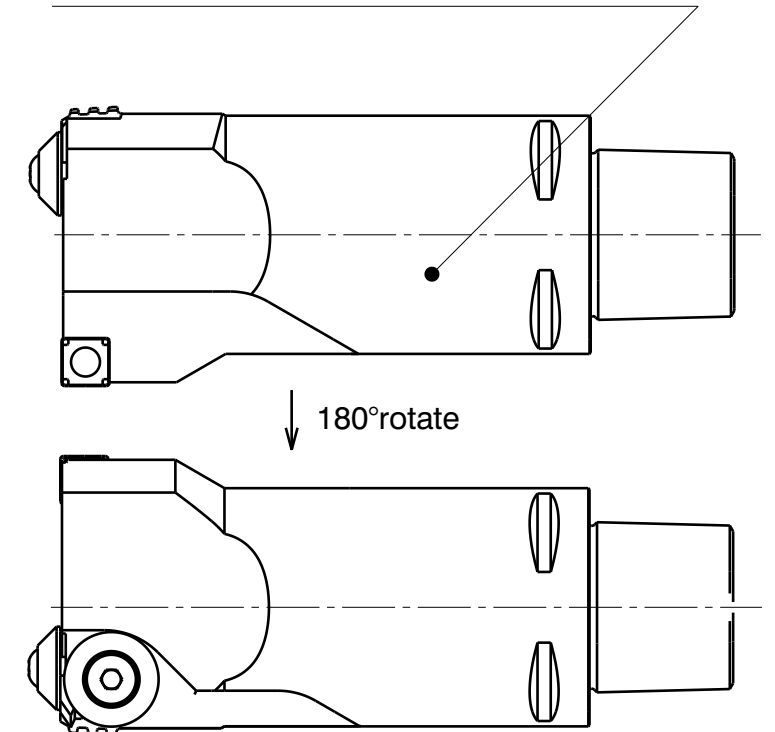

⚠ TungCap BoreMaister Chaser insert

CUT 303/304
I.D. Thread Rough/Finish
 C6-SH-D40-5D-E-CHP
 S40-JS-RF27L32-H(special)
 CR-5B75-3I AH725

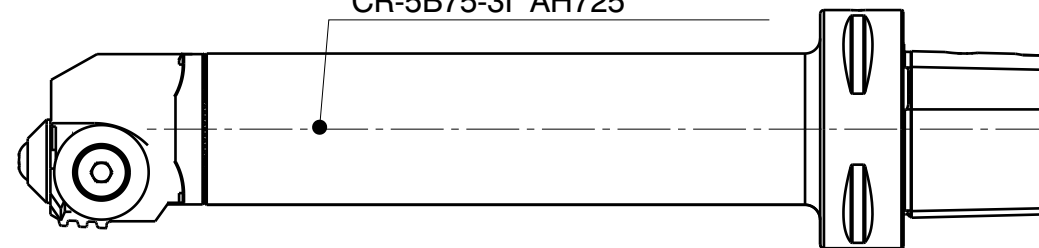

Unspecified Tolerances	Draw		Customer: TUNGALOY	Japan	
Dim.s:	Design		Designation:	LAYOUT OP300-PIPE	
Angles:	Check		Process	Concept	Page 1 Of 1
	Appr.			Layout.	Rev. No.
	Scale				1
					Reg.No. 62317/1
					A3L

