

MODEL IN SCALE 1:1

Machine : Horizontal Lathe  
Turret : 25x25

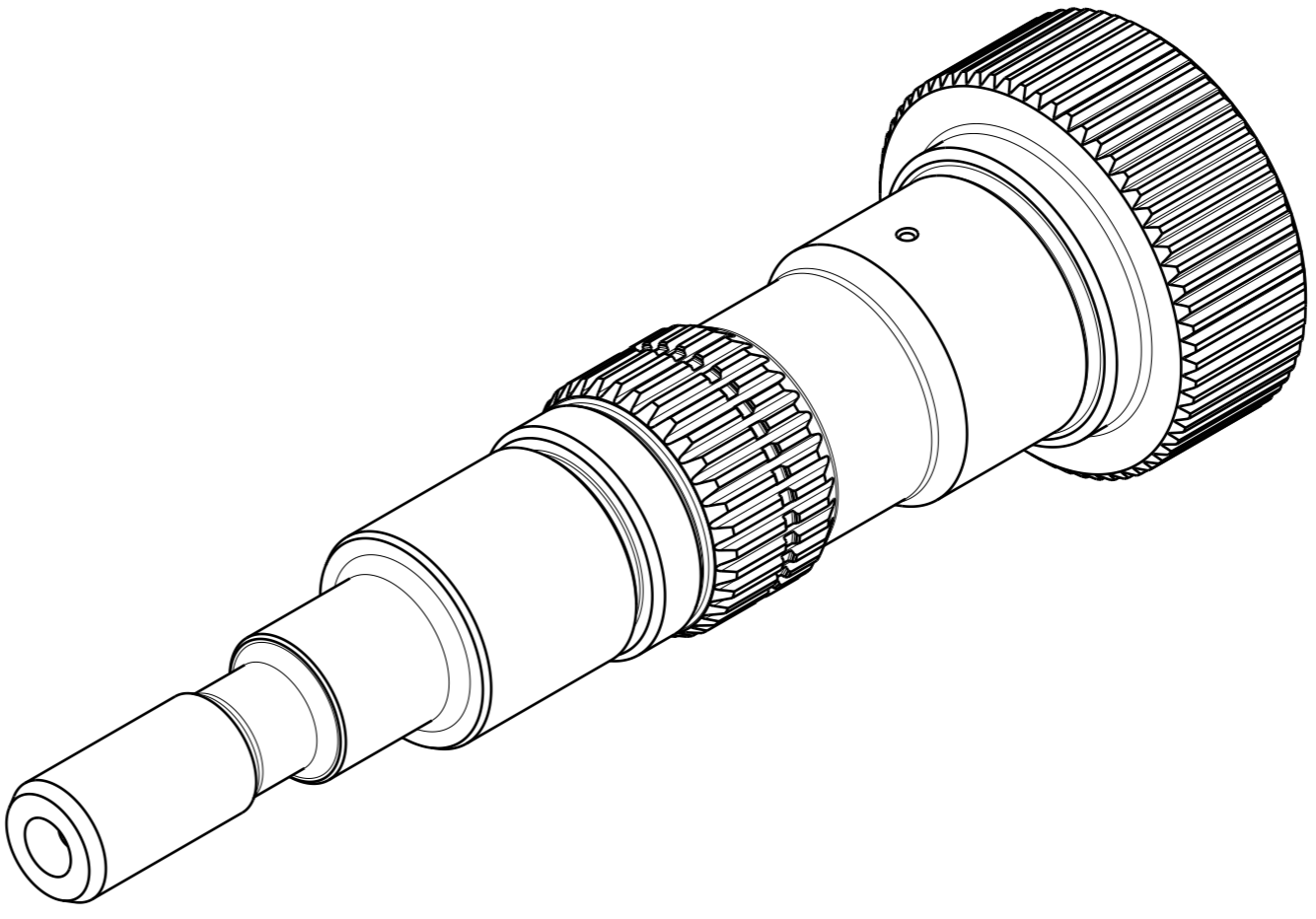

Machine : Vertical M/C

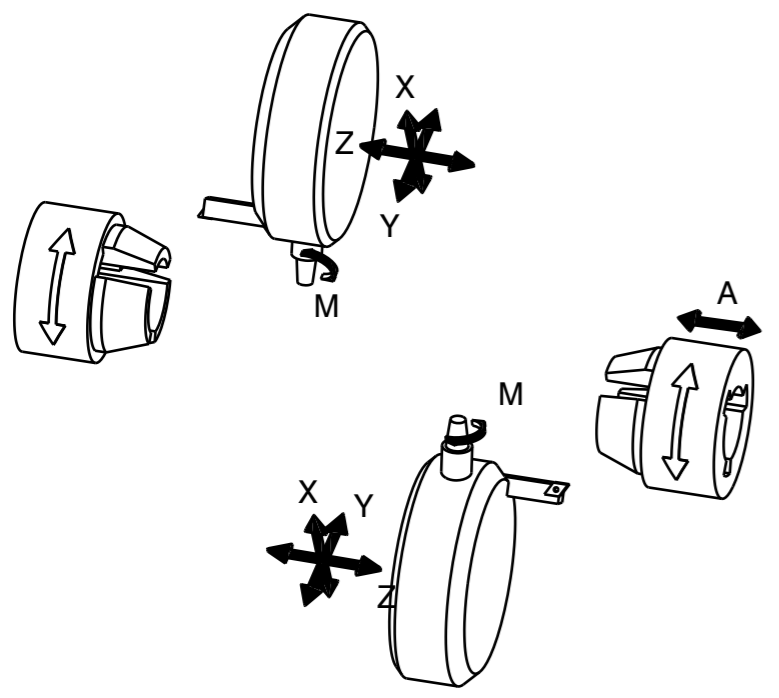
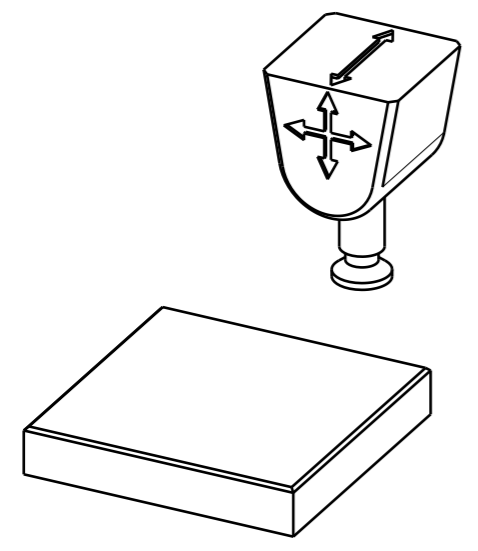

WORK : Shaft

WORKPIECE MATERIAL - Chromium steel

Unspecified Tolerances		Customer: TUNGALOY	Japan		
Dim.s:	-.	Designation:	LAYOUT-SHAFT-59663/1	Dwg. No. 32446144-HCL	
Angles:	-.	Process	Lead Drawing	Layout.	Page 1 Rev. No. 0
					Of 1
					Reg. No. 59663/1
					A3L

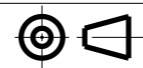

© 2019 Tungaloy Corporation  
- Copyrights Notice



MODEL IN SCALE 1:1 TOOLS IN SCALE 1:1

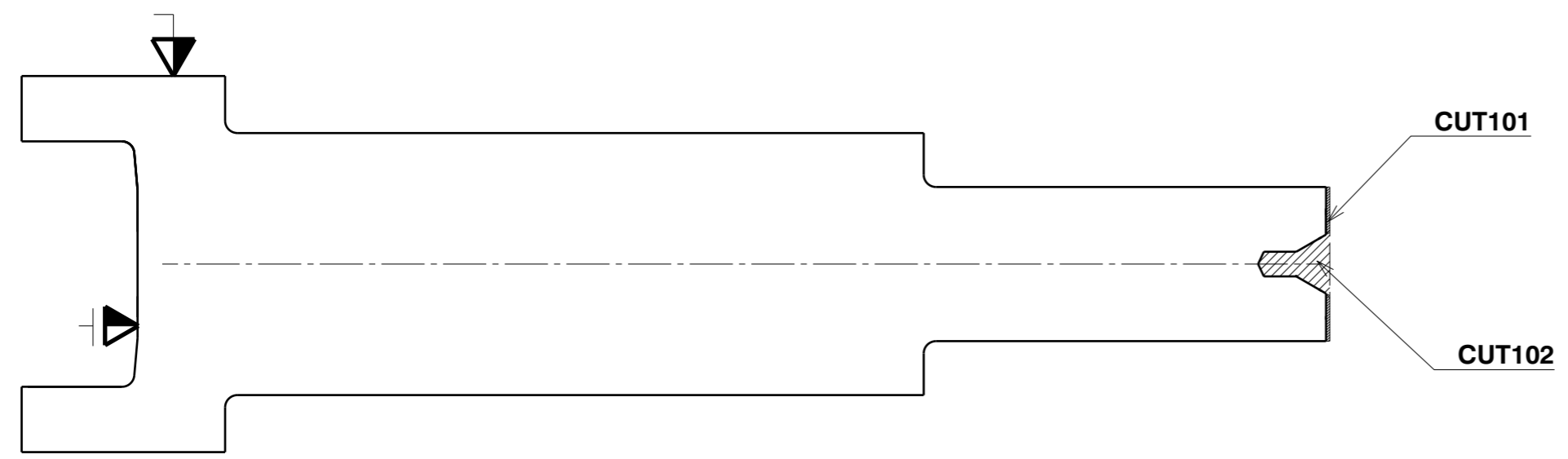

**DoPent**  
**CUT 101/103**  
**Face Milling Finish**  
 TEN09R100M31.7-12  
 PNMU0905GNEN-MJ AH3135

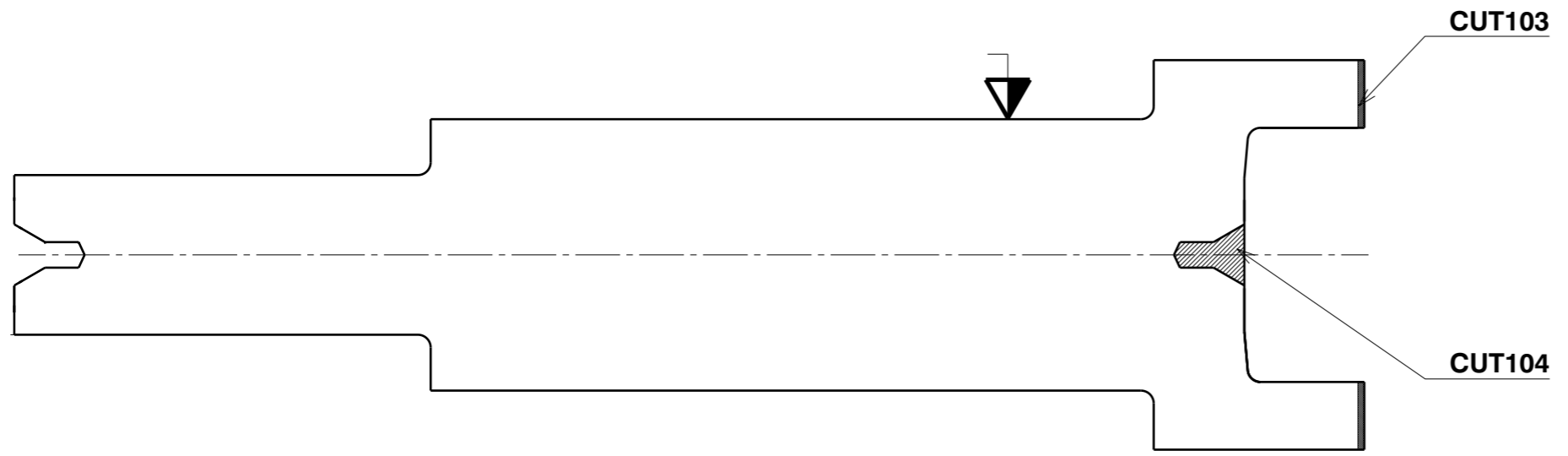
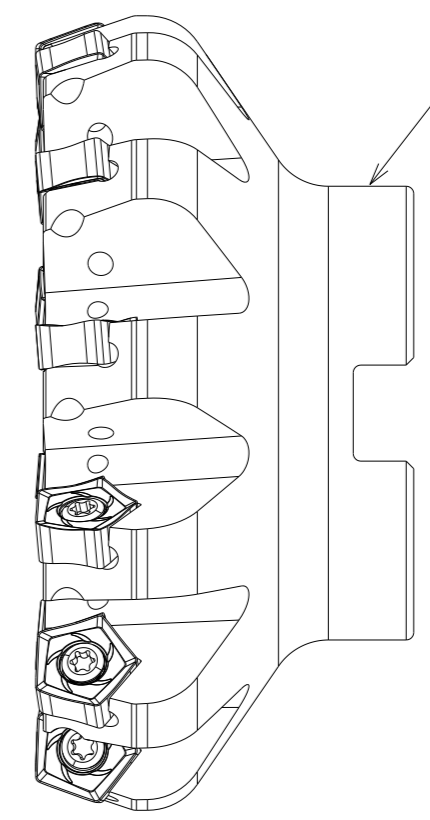

**TungMeister**  
**CUT 102/104**  
**Center drill Rough**  
 VSSD12L070S08-W-A  
 VDP513L07.2A30-02S08AH725

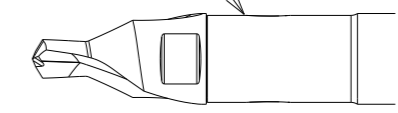

**M/C : Face milling and center hole making**

Unspecified Tolerances	Draw		Customer: TUNGALOY	Japan	
	Design				
Dim.s: -.-	Check		Designation: LAYOUT-OP100-SHAFT-59663/1		Dwg.No. 32446144-HC
	Angles: -.-	Appr.		Process	Page 1 Of 1
	Scale		Concept	Layout.	Rev. No.
	© 2019 Tungaloy Corporation - Copyrights Notice			-.-	Reg.No. 59663/1
			FL-40026486		

MODEL IN SCALE 1:1 TOOLS IN SCALE 1:1

### TungTurn-Jet T9200

**CUT 201/202**  
**OD Turning Rough**  
ACLNL2525X-12-CHP-MC  
CNMG120412-TM T9215

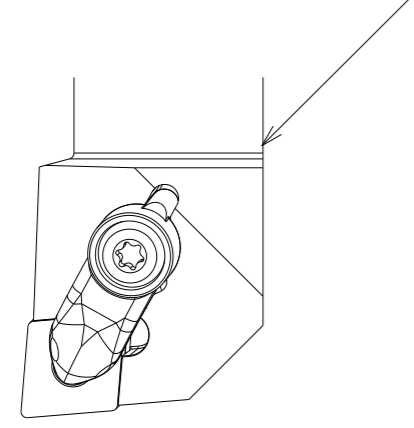

### TungTurn-Jet T9200

**CUT 201/202**  
**OD Turning Rough**  
PCLNL2525M12-CHP  
CNMG120412-TM T9215

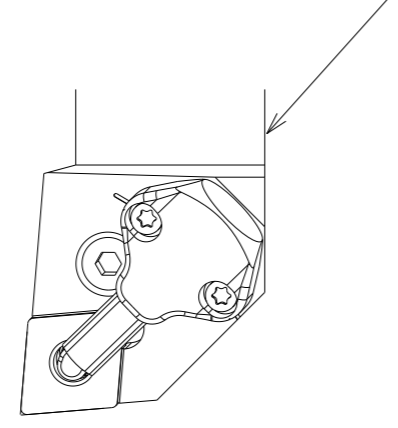

### TungTurn-Jet ISO-EcoTurn T9200

**CUT 201/202**  
**OD Turning Rough**  
PCLNL2525M0904-CHP  
CNMG090412E-TM T9215

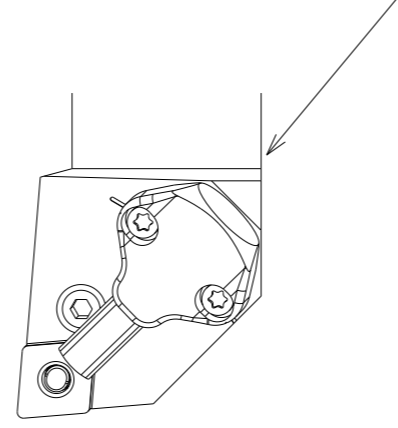

### TungTurn-Jet ISO-EcoTurn T9200

**CUT 203**  
**OD Turning Finish**  
PDJNL2525M1104-CHP  
DNMG110408E-TSF T9215

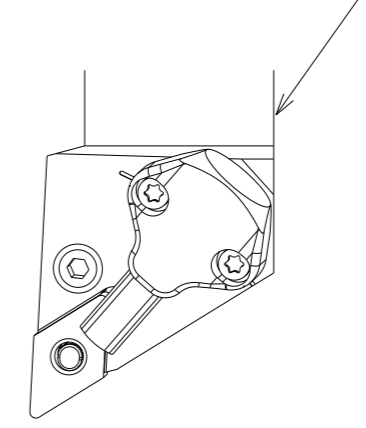

### TungTurn-Jet ISO-EcoTurn T9200

**CUT 204**  
**OD Turning Finish**  
PCLNR2525M0904-CHP  
CNMG090408E-TSF T9215

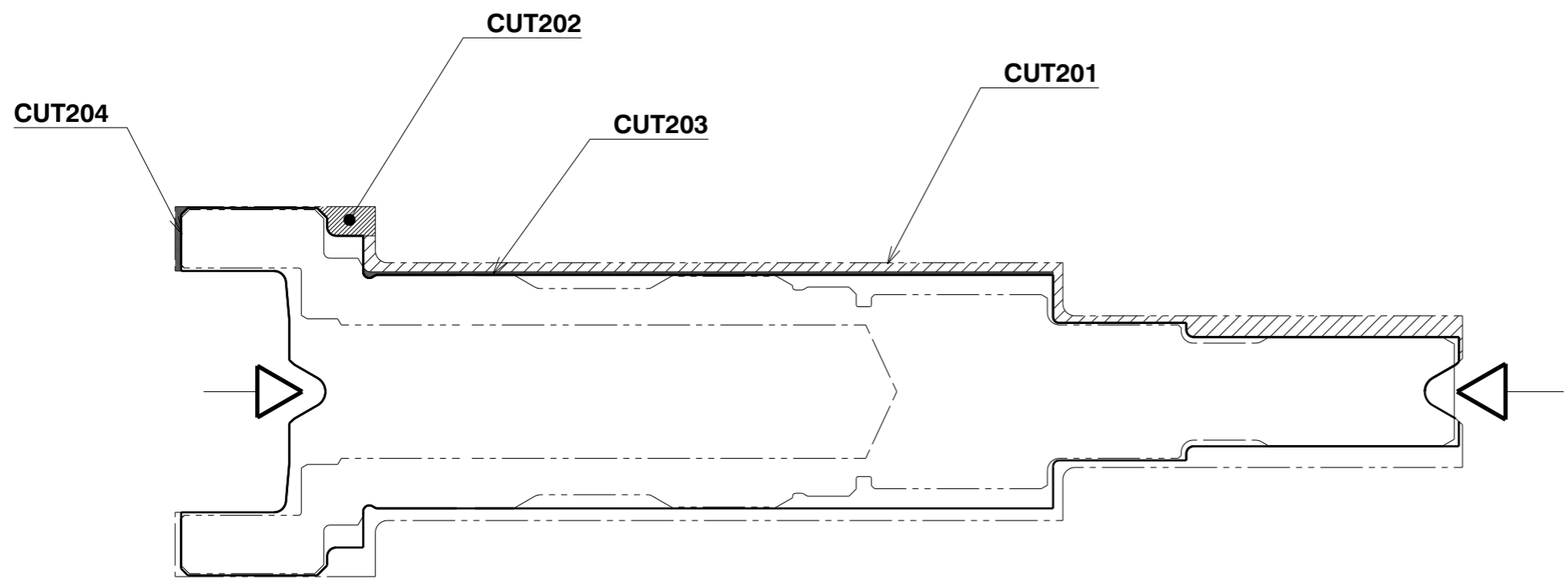
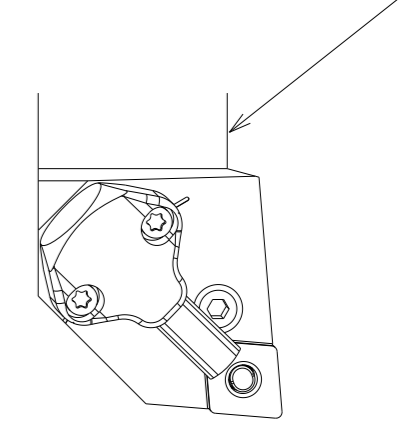

# Lathe : O.D.

Unspecified Tolerances	Draw		Customer: TUNGALOY	Japan	
	Design				
Dim.s:	Check		Designation:		Dwg.No.
	Appr.		LAYOUT-OP200-SHAFT-59663/1		32446144-HC1
Angles:	Scale		Process	Layout.	Page 1
			Concept		Of 1
	© 2019 Tungaloy Corporation - Copyrights Notice		-		Rev. No.
			FL-40026486		0
			Reg.No.		A3L
			59663/1		

MODEL IN SCALE 1:1 TOOLS IN SCALE 1:1

**TungSix-Drill**  
**CUT 301**  
**ID Rough**  
 TDS450F40-2  
 WWMU11X512R-DJ AH9030

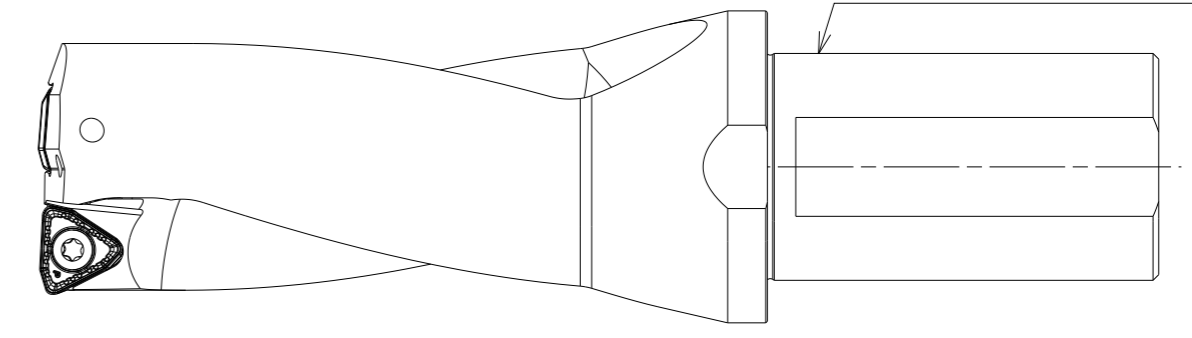

**DrillMeister**  
**CUT 302**  
**Hole making Rough**  
 TID220F25-1.5  
 DMP220 AH725

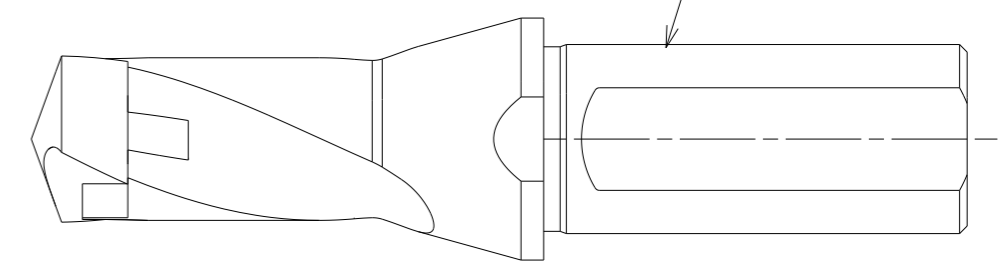

**TungBoreMini**  
**CUT 301/302**  
**ID Turning Rough**  
 TID220F25-1.5  
 XOMU08T304-PS AH725

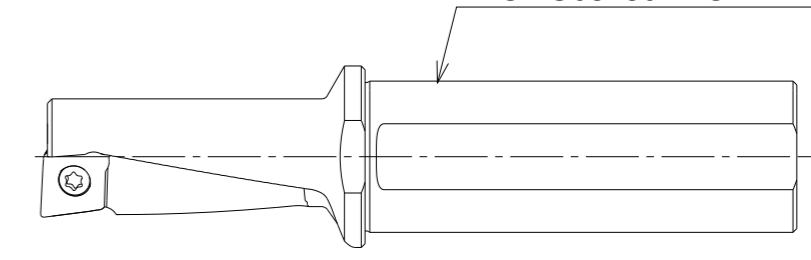

**MiniForceTurn**  
**CUT 303**  
**ID Turnig Finish**  
 A16Q-SDXXL07-D200  
 DXGU070304R-TS

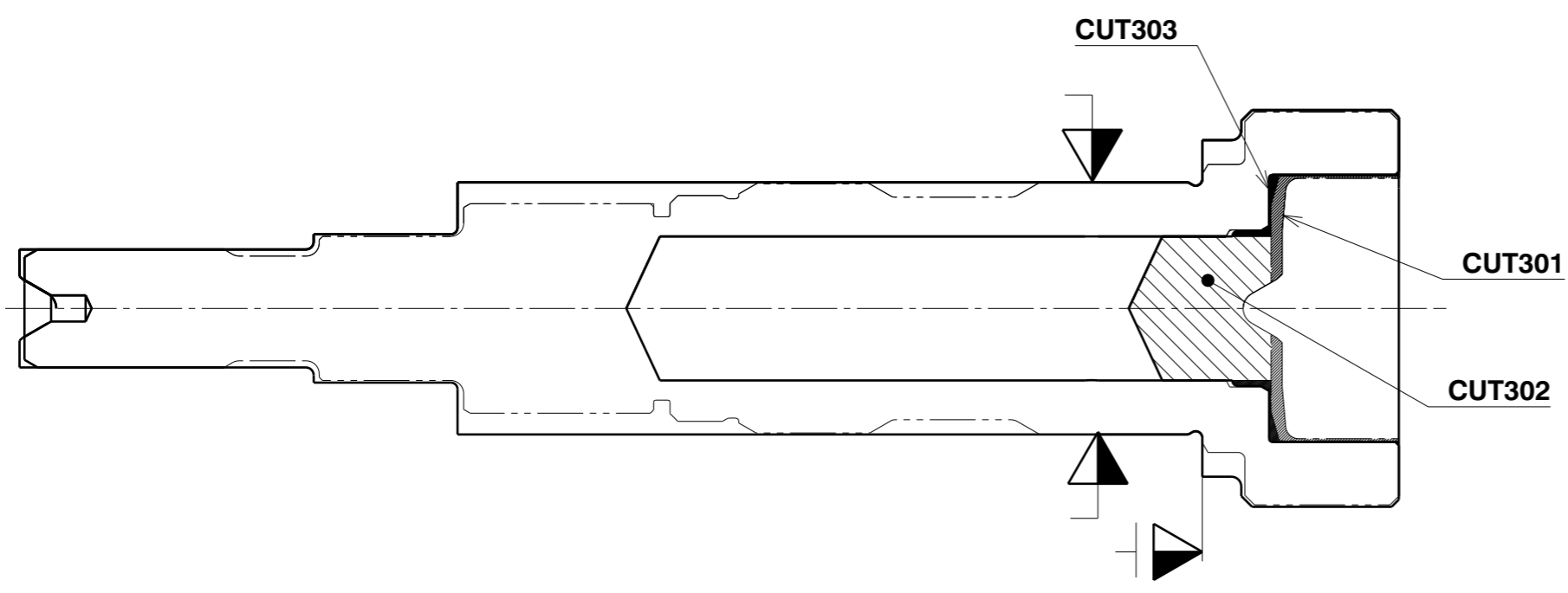
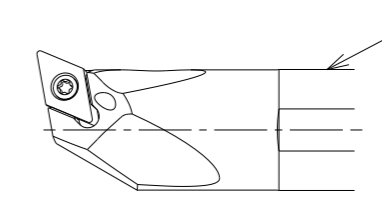

**Lathe : I.D.**

Unspecified Tolerances	Draw		Customer: TUNGALOY	Japan	
	Design				
Dim.s:	Check		Designation:		Dwg.No.
	Appr.		LAYOUT-OP300-SHAFT-59663/1		32446144-HC2
Angles:	Scale		Process	Layout.	Page 1
			Concept		Of 1
					Rev. No.
					0
					Reg.No.
					59663/1
					A3L

© 2019 Tungaloy Corporation  
 Copyrights Notice



FL-40026486

MODEL IN SCALE 1:1 TOOLS IN SCALE 1:1

**CUT 401/402/403**  
**OD Turning Finish**  
 PDJNL2525M1104-CHP  
 DNMG110408E-TSF T9215

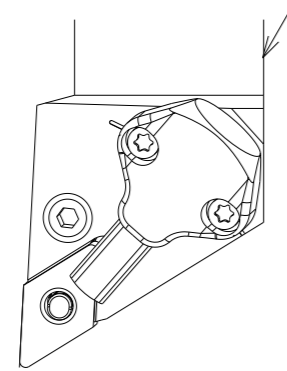

**TungTurn-Jet**  
**ISO-EcoTurn**

**CUT 404/405/406**  
**OD Turning Finish**  
 PVJNL2525M1204-CHP  
 VNMG120408E-TSF T9215

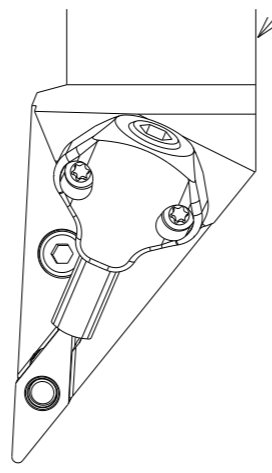

**CUT 407**  
**OD Turning Finish**  
 SYQBL2525M16  
 YWMT16T408-ZF T9225

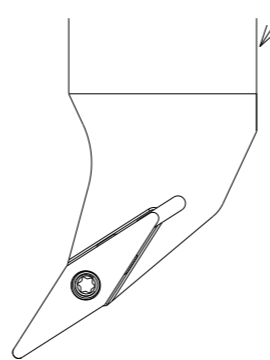

**Y-Pro**

**CUT 408**  
**OD Turning Finish**  
 STCL2525Z18-CHP  
 TCS18R200-020 AH7025

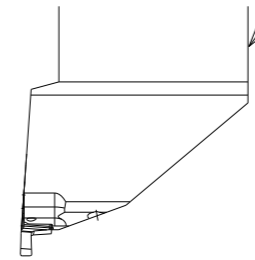

**TetraMiniCut**

**CUT 409**  
**OD Turning Finish**  
 STCL2525-27-CHP  
 TCM27-250-030 AH725

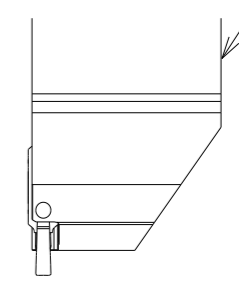

**TetraForceCut**

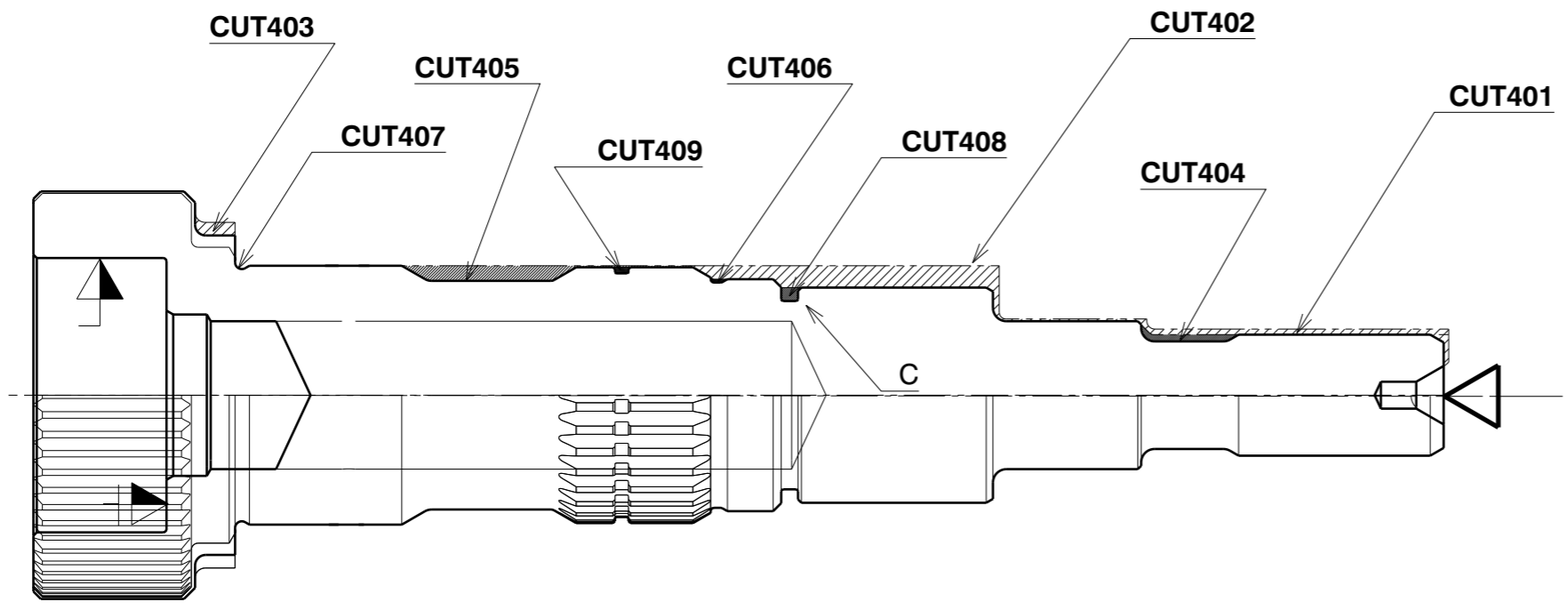

**Lathe : O.D.**

Unspecified Tolerances	Draw		Customer: TUNGALOY	Japan	
Dim.s: --	Design		Designation: LAYOUT-OP400-SHAFT-59663/1		
Angles: --	Check		Process	Layout.	Page 1 Rev. No. 0
	Appr.		Concept		Reg.No. 59663/1
	Scale		--		A3L
			FL-40026486		

MODEL IN SCALE 1:1 TOOLS IN SCALE 1:1

**DrillMeister**  
**CUT 501**  
**Hole making Finish**  
 TID230F32-5  
 DMP230 AH725

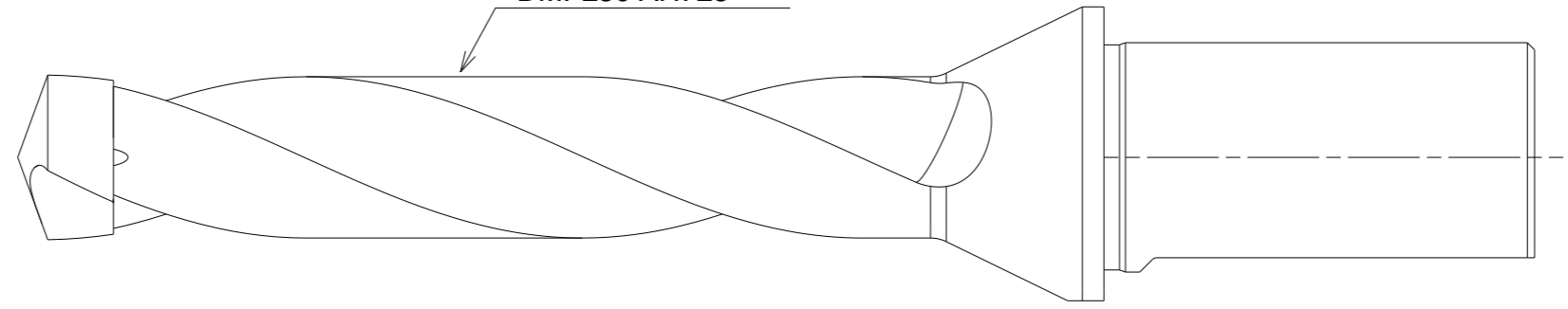

**CUT 502**  
**Centering & Chamfering Finish**  
 VER11CL006S05-S  
 VCP080L07.7A45-02S05

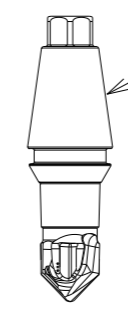

**TungMeister**

**CUT 503**  
**Holemaking Finish**  
 DSM0200G05 YH180



**GigaMiniDrill**

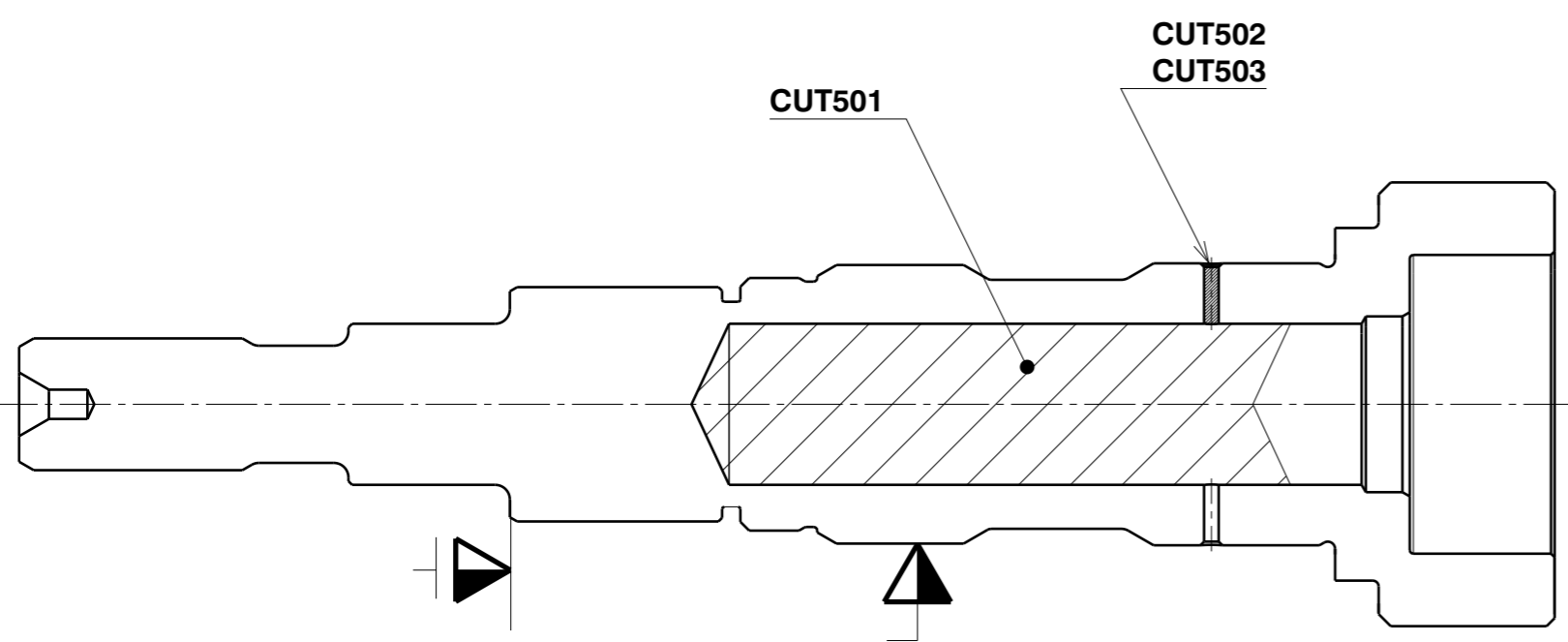

**Hole making**

Unspecified Tolerances	Draw		Customer: TUNGALOY	Japan	
	Design		Designation: LAYOUT-OP500-SHAFT-59663/1		
Dim.s: -.-	Check		Process		Page 1
Angles: -.-	Appr.		Concept		Of 1
	Scale		-		Rev. No. 0
	© 2019 Tungaloy Corporation - Copyrights Notice		FL-40026486		Reg. No. 59663/1
					A3L

MODEL IN SCALE 1:1 TOOLS IN SCALE 1:1

**CUT 801**  
**OD Turning Finish**  
 ACLNL2525X-12-CHP-MC  
 2QP-GNGG120404-HP BXA20

**CUT 802**  
**OD Turning Finish**  
 DCLNR2525M12  
 4QS-CNGA120408-H BXA20

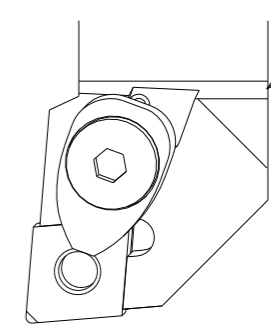
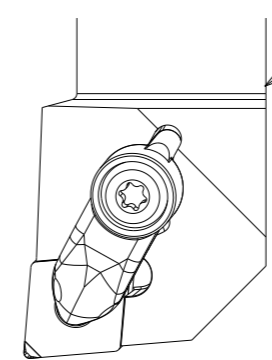

**TungTurn-Jet**  
**T-CBN BXA**

**TungTurn-Jet**  
**T-CBN WavyJoint BXA**

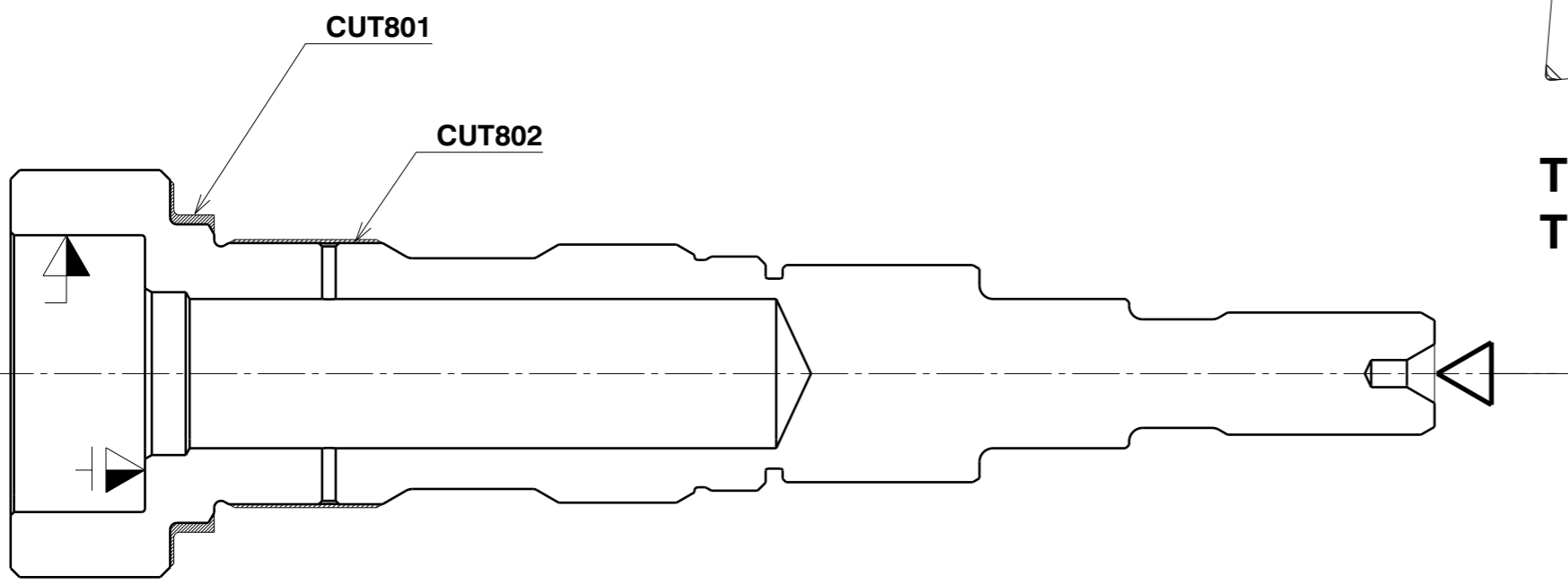

**StreamJetBar**  
**T-CBN BXA**

**CUT 901**  
**ID Tugning Finish**  
 A16K-SCLCL09-D200  
 2QP-CCGW09T304 BXA20

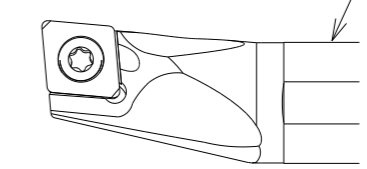

CUT901

**Lathe : Hard turning**

Unspecified Tolerances	Draw		Customer: TUNGALOY	Japan	
	Design				
Dim.s:	Check		Designation:		Dwg.No.
	Appr.		LAYOUT-OP800-SHAFT-59663/1		32446144-HC5
Angles:	Scale		Process		Page 1
			Concept		Rev. No. 0
			Layout.		Of 1
			-		Reg.No.
			FL-40026486		59663/1
					A3L



© 2019 Tungaloy Corporation  
 Copyrights Notice

