

**MODEL IN SCALE 1:1**

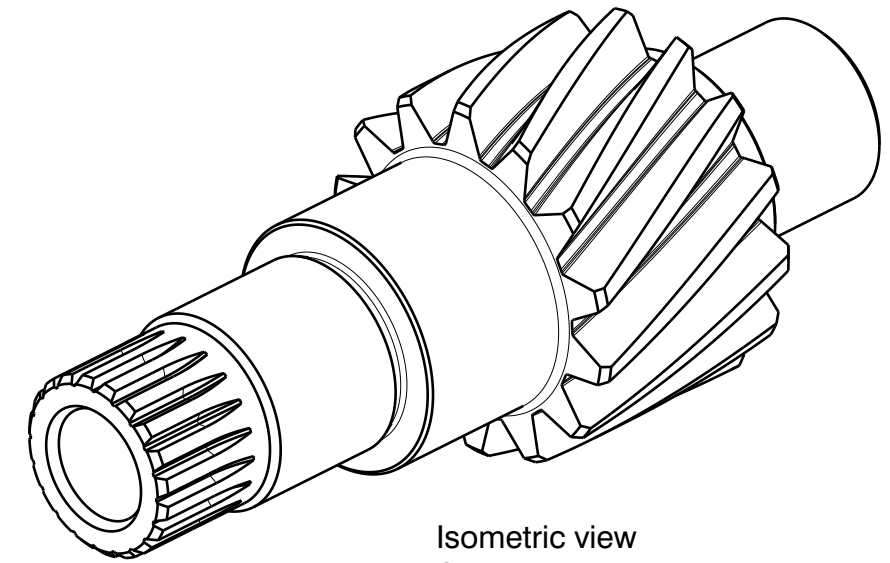

Isometric view  
Scale: 1:1

Machine : Centering Machine

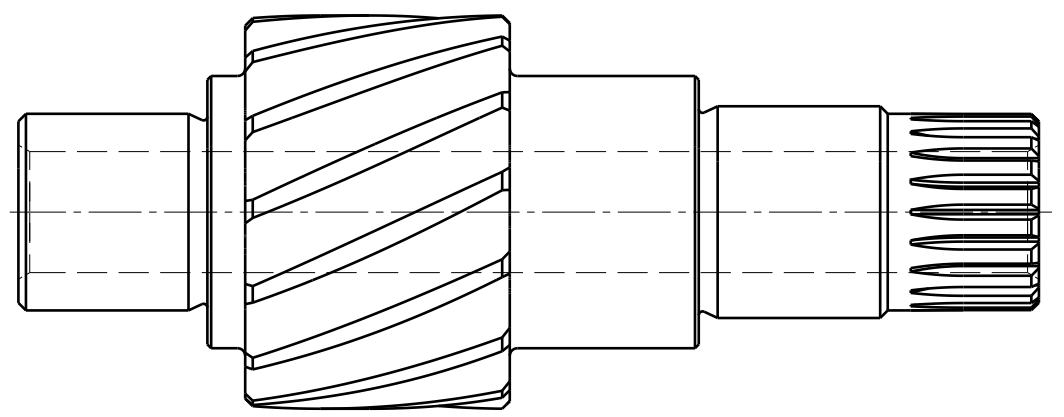
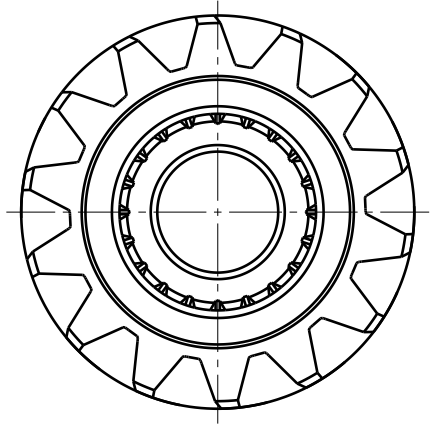
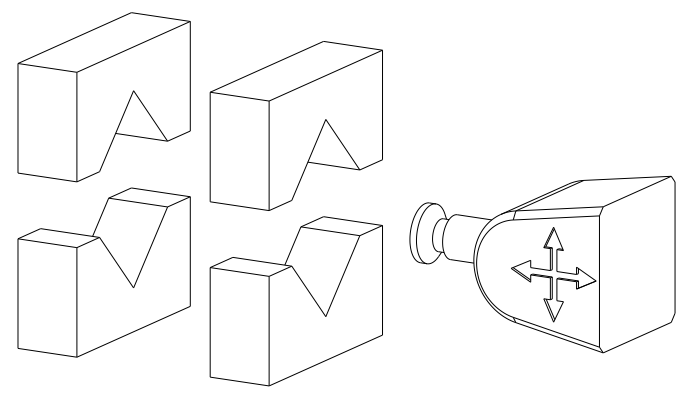

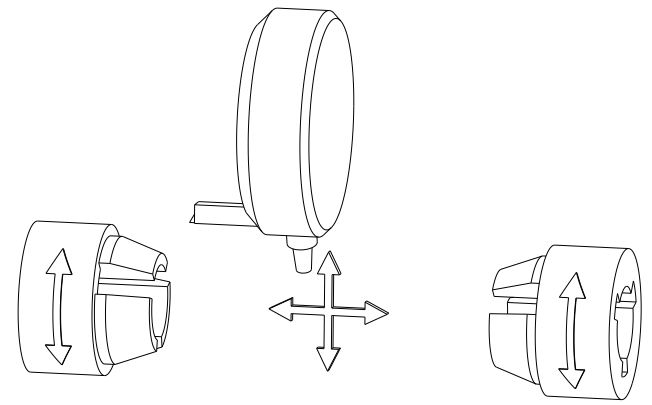

Machine : Horizontal Lathe



**WORK : MOTOR DRIVE**

**WORKPIECE MATERIAL : Chromium steel**

Unspecified Tolerances	Draw		Customer: TUNGALOY	Japan	
	Design		Designation: LAYOUT-MOTOR DRIVE-71877		
Dim.s: --	Check		Process		Page 1
	Appr.		Lead Drawing		Rev. No. 0
Angles: --	Scale		Layout.		Of 1
			-		Reg.No. 71877/1
	© 2023 Tungaloy Corporation - Copyrights Notice		FL-40054246		A3L

MODEL IN SCALE 1:1 TOOLS IN SCALE 1:2

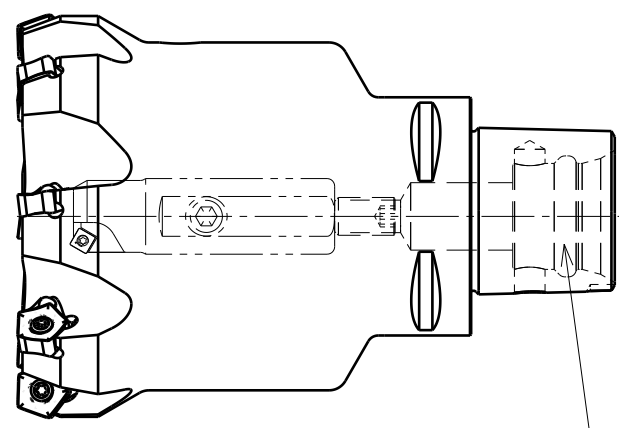

**CUT101/102/103/104**  
**Face milling Finish / O.D. I.D. Chamfering**  
 C6-KAF100C70Z8 (Special)  
 KBM-15A30L70S20 (Special)  
 SDMT050204PN-MJ AH725  
 Cartridge (Special)  
 SPMN120408 AH120  
 PNCU0905GNEN-MJ AH3225

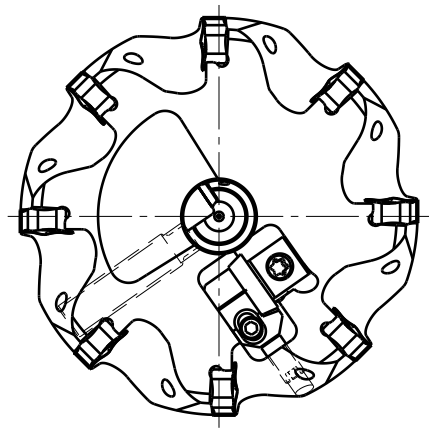

**TungCap**  
**DoPent**  
**TungQuad**

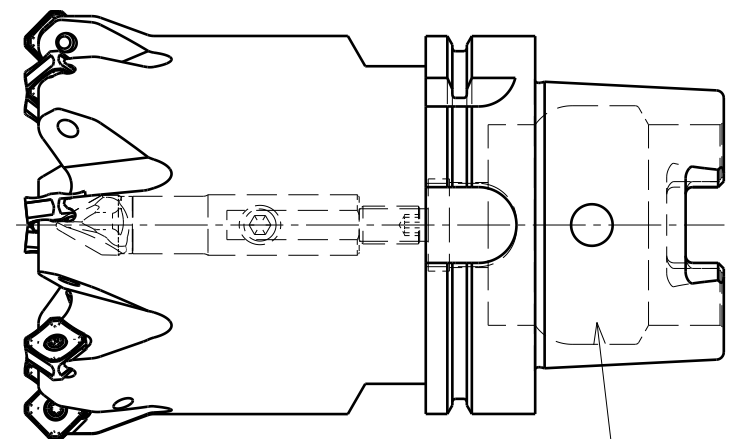

**CUT101/102/103/104**  
**Face milling Finish / O.D. I.D. Chamfering**  
 HSKA100-KAF100C45Z8 (Special)  
 VSSD16L100S10-S-T2 (Special)  
 VCP160L15.0A30-02S10AH725  
 Cartridge (Special)  
 SPMN120408 AH120  
 SNGU1307ANEN-MJ AH3225

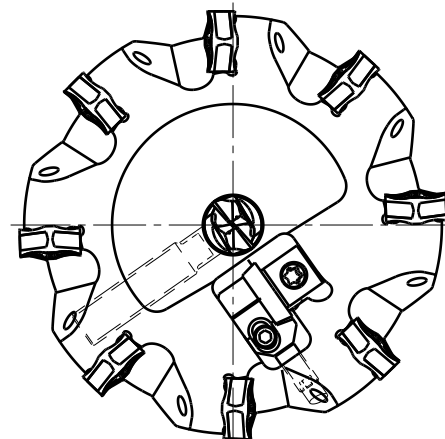

**DoTriple-Mill**  
**TungMeister**

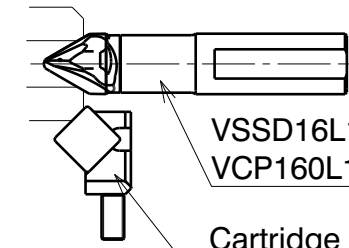

VSSD16L100S10-S-T2 (Special)  
 VCP160L15.0A30-02S10AH725  
 Cartridge (Special)  
 SPMN120408 AH120

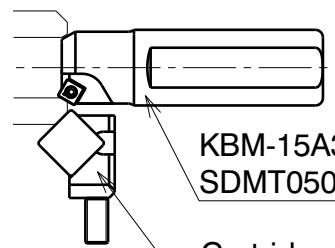

KBM-15A30L70S20 (Special)  
 SDMT050204PN-MJ AH725  
 Cartridge (Special)  
 SPMN120408 AH120

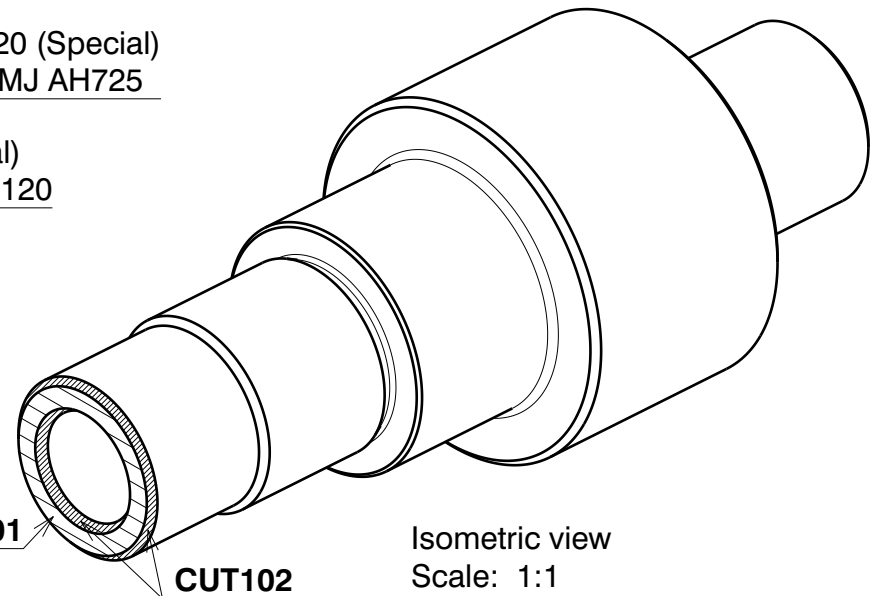

CUT101 CUT102 Isometric view Scale: 1:1

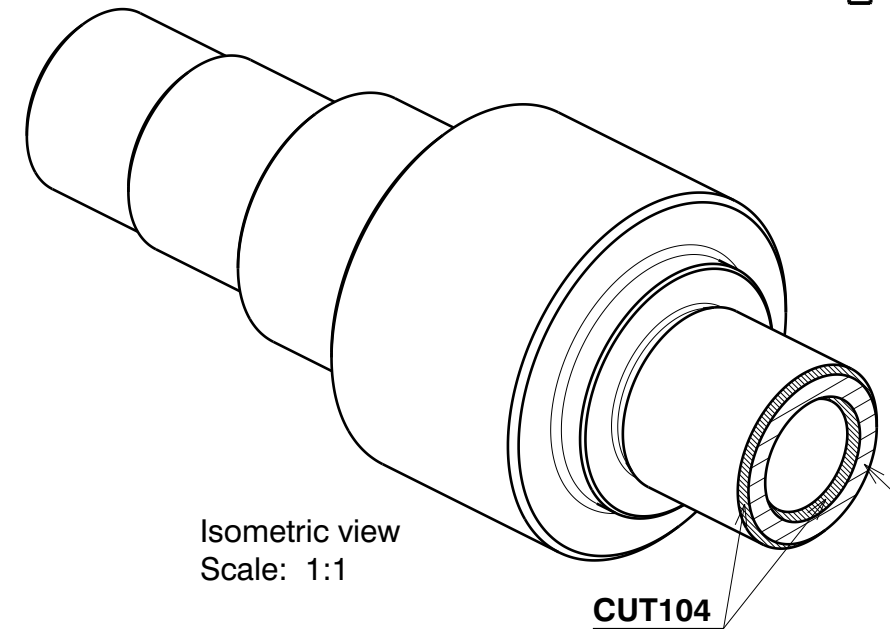

CUT103 CUT104 Isometric view Scale: 1:1

**Centering Machine**  
**Face milling and O.D. I.D. Chamfering**

Unspecified Tolerances	Draw		Customer: TUNGALOY	Japan	
Dim.s:	Design		Designation:		
Angles:	Check		LAYOUT-MOTOR DRIVE-71877		Page 1 Rev. 1
	Appr.		Process	Layout.	Of 1 No. 1
	Scale		Concept		Reg.No. 71877/1
					A3L
			FL-40054246		

MODEL IN SCALE 1:1 TOOLS IN SCALE 1:1

**CUT201**  
**OD turning Rough**  
 ATXOR2525M25-A  
 6C-TOMG250608M-TM T9215

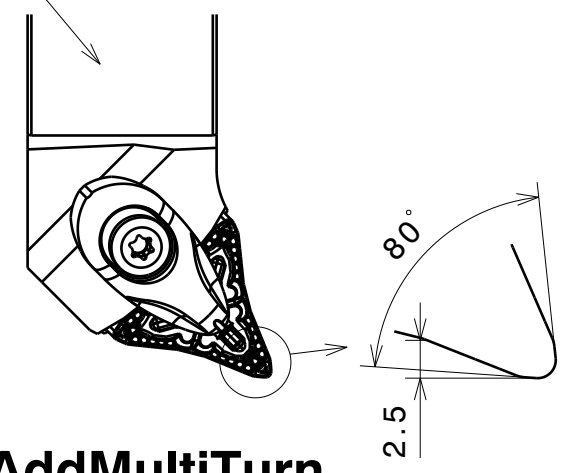

**AddMultiTurn**  
**T9200**

**CUT202**  
**OD turning Rough**  
 ATXOL2525M25-A  
 6C-TOMG250608M-TM T9215

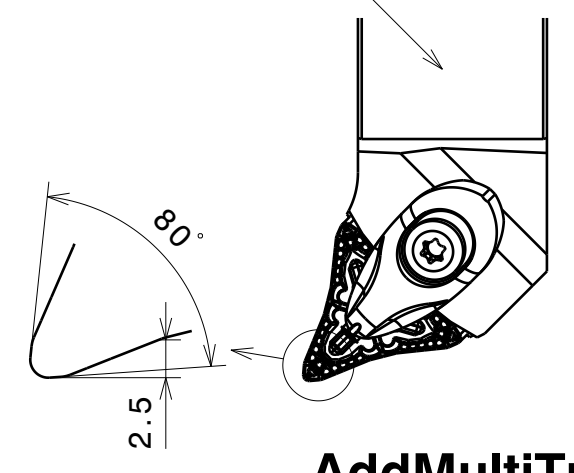

**AddMultiTurn**  
**T9200**

**CUT203**  
**OD turning Finish**  
 ATXOR2525M25-A  
 6V-TOMG250608F-TSF T9215

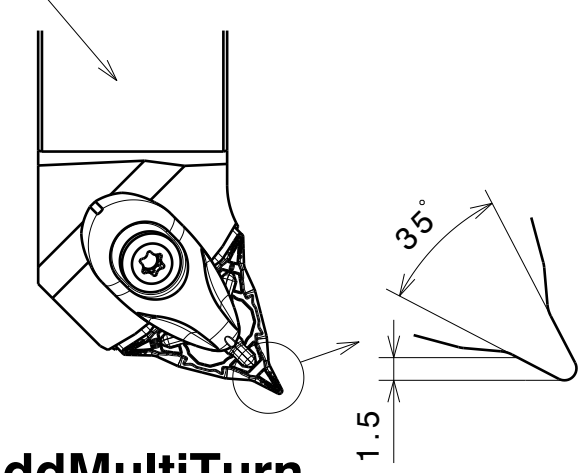

**AddMultiTurn**  
**T9200**

**CUT 204**  
**OD Turning Finish**  
 C4PDJNL27055-1104-CHP  
 FNMG110408E-TSF T9215

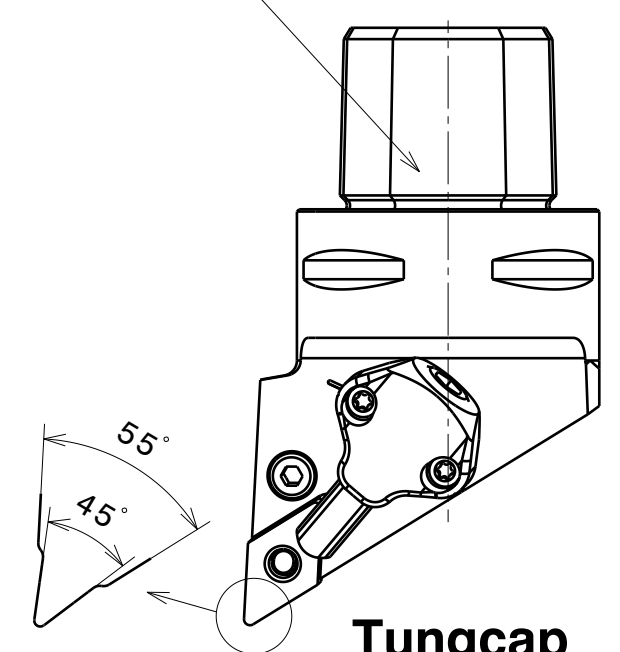

**Tungcap**  
**TungTurn-Jet**  
**ISO-EcoTurn**  
**T9200**

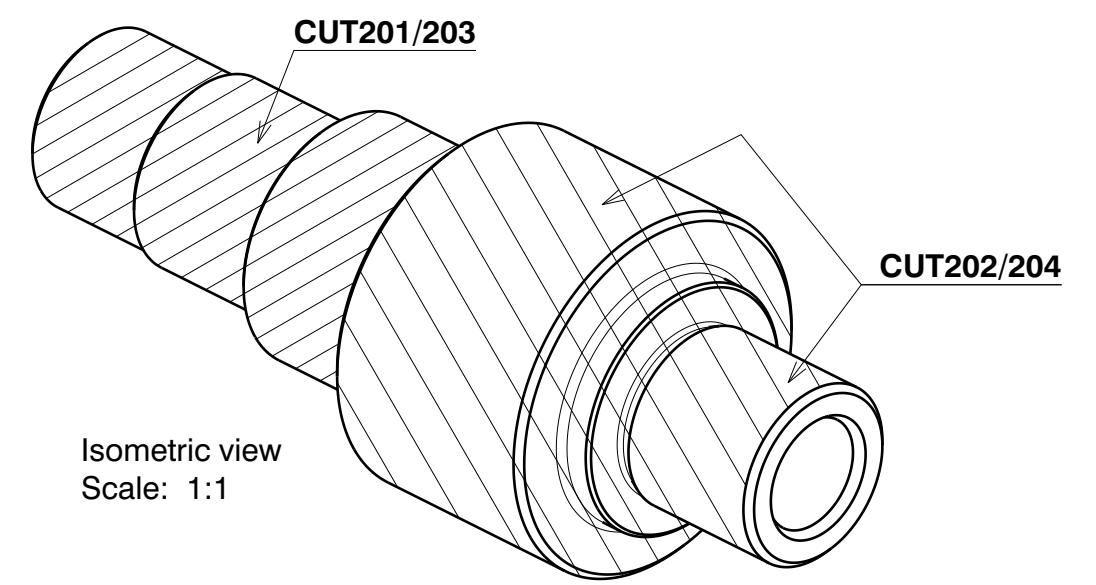
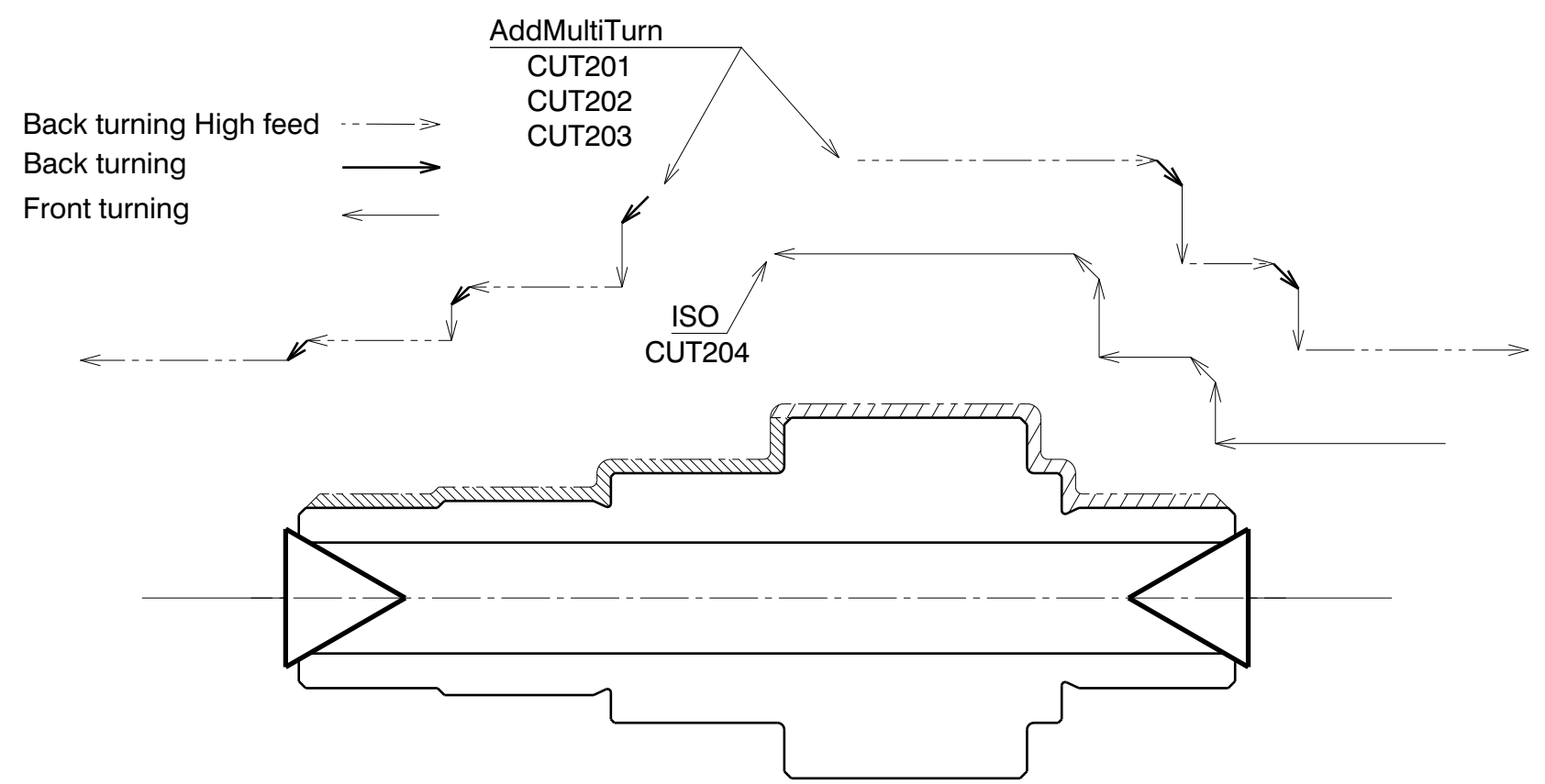

Isometric view  
 Scale: 1:1

**Lathe : O.D.turning**

Unspecified Tolerances	Draw		Customer: TUNGALOY	Japan	
	Design		Designation:		
Dim.s: --	Check		LAYOUT-MOTOR DRIVE-71877		Page 1
	Appr.		Process	Layout.	Rev. No. 0
Angles: --	Scale		Concept		Reg.No. 71877/1
	© 2023 Tungaloy Corporation - Copyrights Notice		FL-40054246		A3L

MODEL IN SCALE 1:1 TOOLS IN SCALE 1:1

**CUT301**  
**Face turning Finish**  
 ADJNL2525X-15-CHP-MC  
 DNMG150608-TSF T9225

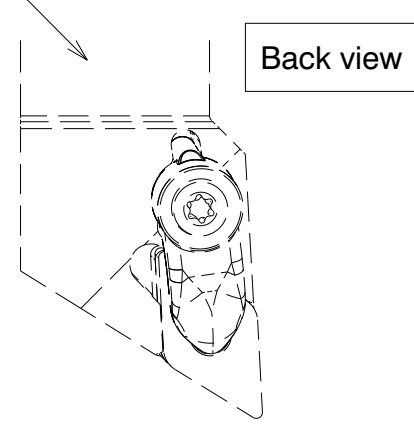

**TungTurn-Jet  
T9200**

**CUT301**  
**Face turning Finish**  
 C4ADJNL27050-1104N  
 DNMG110408E-TSF T9225

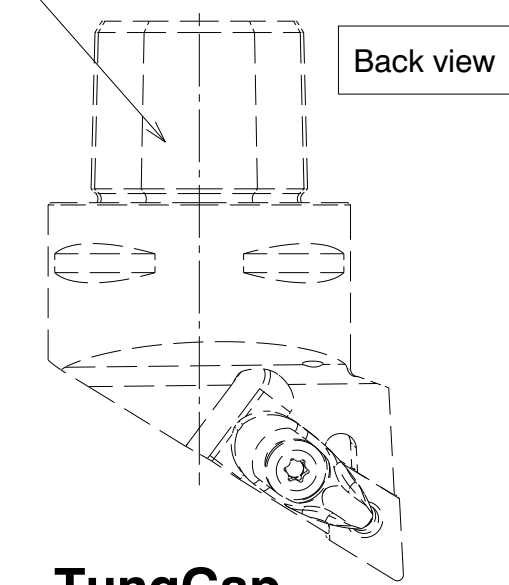

**TungCap  
ISO-EcoTurn  
T9200**

**CUT302**  
**Face turning Finish**  
 ACLNL2525X-12-CHP-MC  
 CNMG120408-TSF T9225

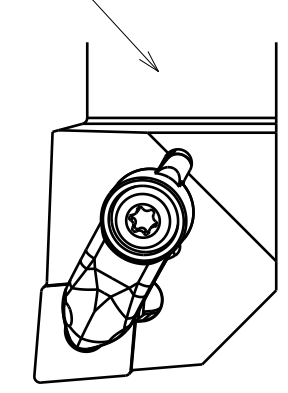

**TungTurn-Jet  
T9200**

**CUT302**  
**Face turning Finish**  
 C4ACLNL27050-0904N  
 CNMG090408E-TSF T9225

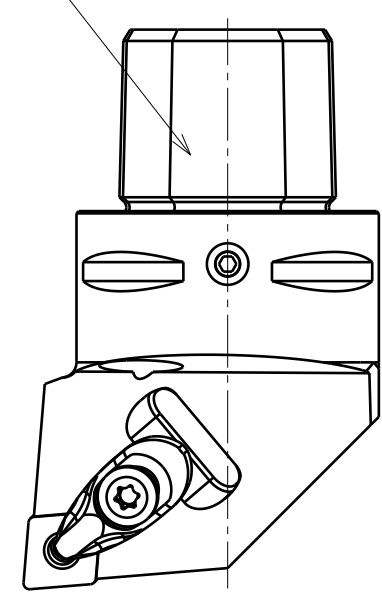

**TungCap  
ISO-EcoTurn  
T9200**

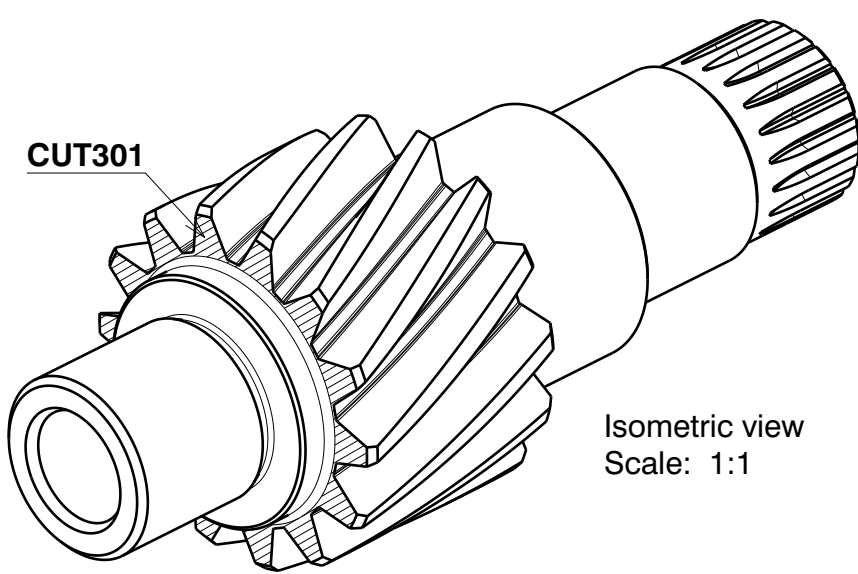

Isometric view  
Scale: 1:1

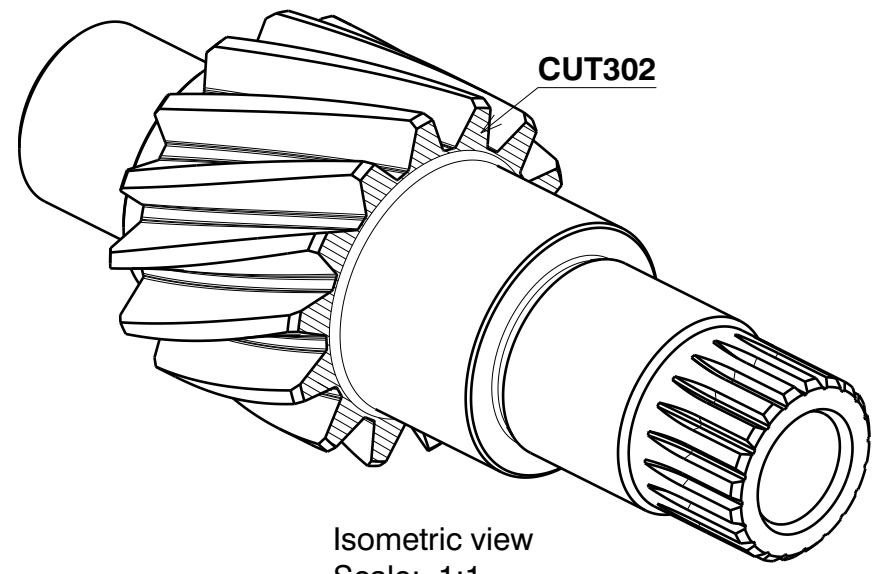

Isometric view  
Scale: 1:1

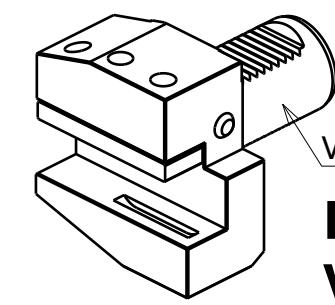

VDI40B1B4A-402544-JHPMC

**DirectTung-Jet  
VDI Adapter**

Isometric view  
Scale: 1:3

**Lathe : Face turning [After gear milling]**

Unspecified Tolerances	Draw		Customer: TUNGALOY	Japan	
Dim.s:	Design		Designation:		
--	Check		LAYOUT-MOTOR DRIVE-71877		Page 1
Angles:	Appr.		Process	Layout.	Rev. No. 1
--	Scale		Concept		Reg.No. 71877/1
	© 2024 Tungaloy Corporation - Copyrights Notice				A3L
			FL-40054246		

# MODEL IN SCALE 1:1 TOOLS IN SCALE 1:1

**CUT401/402**  
**OD turning Finish**  
 C4CHSN21047-CHP  
 CAER-3T16-CHP  
 STH300-SR BXA10

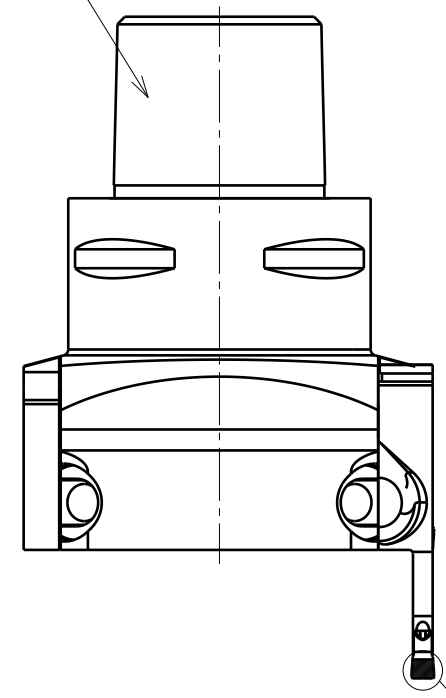

**CUT401**  
**OD turning Finish**  
 ACLNR2525X-12-CHP-MC  
 4QS-CNGA120412-H BXA10

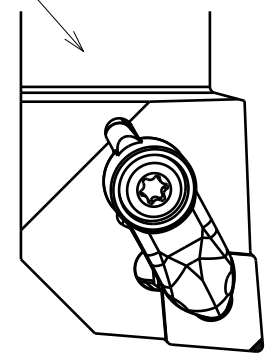

**T-CBN BXA**  
**WavyJoint**  
**TungTurn-Jet**

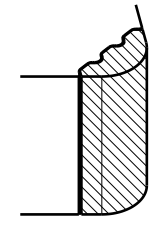

Isometric view  
Scale: 5:1

**CUT401**  
**OD turning Finish**  
 C4PCLNR27050-12-CHP  
 4QS-CNGG120408-HP BXA10

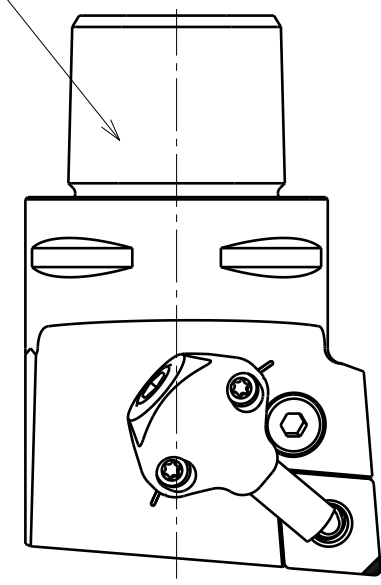

**T-CBN BXA**  
**WavyJoint**  
**HP Breaker**  
**TungCap**  
**TungTurn-Jet**

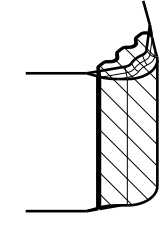

Isometric view  
Scale: 5:1

**CUT402**  
**OD turning Finish**  
 ADJNL2525X-15-CHP-MC  
 4QS-DNGA150412-H BXA10

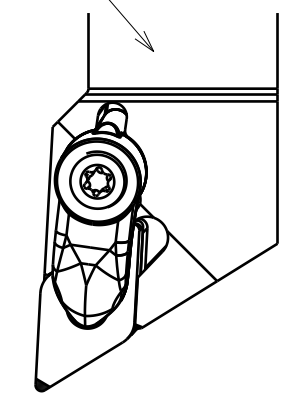

**T-CBN BXA**  
**WavyJoint**  
**TungTurn-Jet**

**CUT402**  
**OD turning Finish**  
 C4PDJNL27055-15-CHP  
 4QS-DNGG150408-HP BXA10

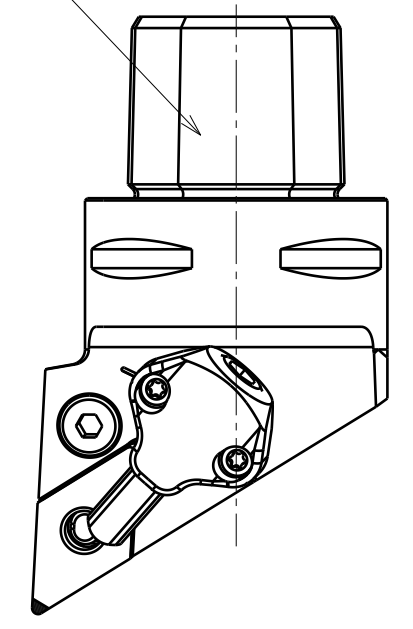

**T-CBN BXA**  
**WavyJoint**  
**HP Breaker**  
**TungCap**  
**TungTurn-Jet**

**T-CBN BXA**  
**WavyJoint**  
**TungCap**  
**TungTurn-Jet**  
**TungModularSystem**  
**TungCut**

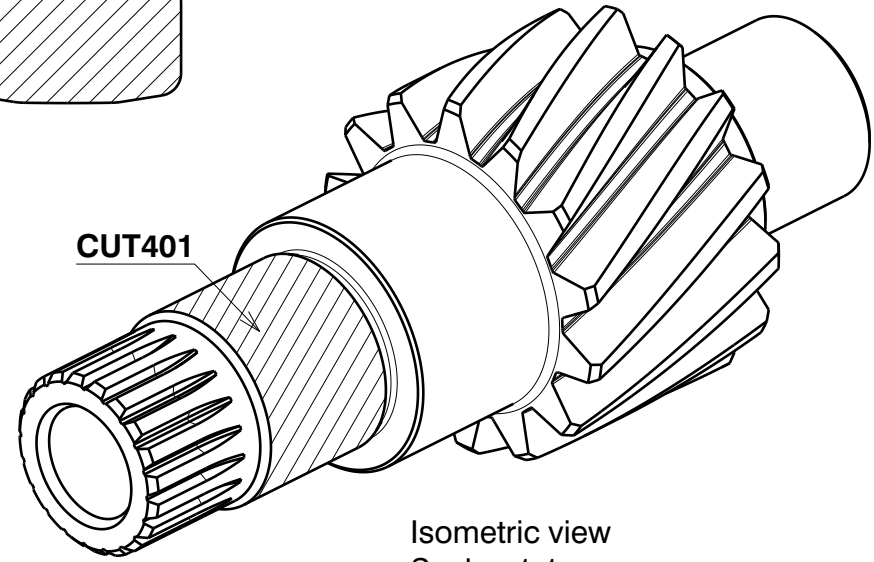
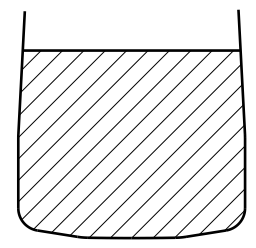

Isometric view  
Scale: 1:1

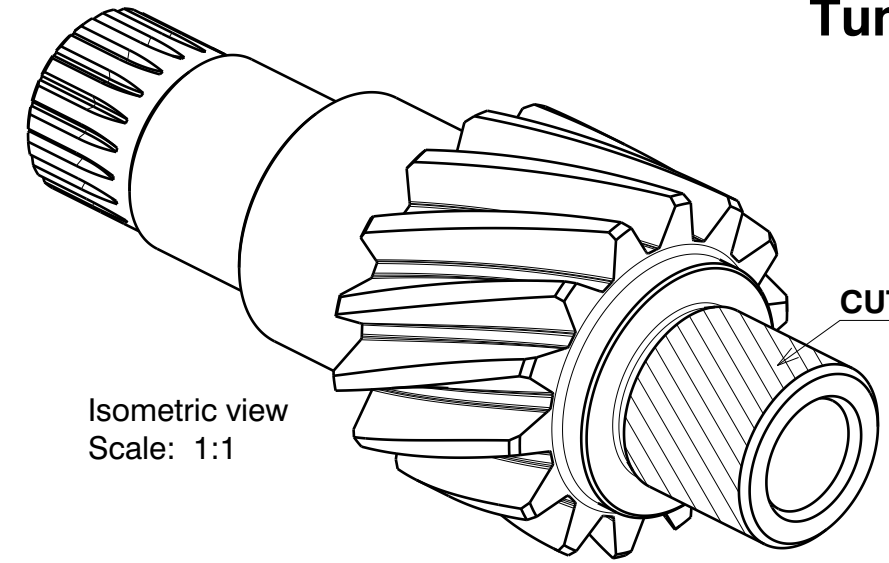

Isometric view  
Scale: 1:1

**Lathe : O.D. turning [After quenching]**

Unspecified Tolerances	Draw		Customer: TUNGALOY	Japan	
Dim.s:	Design		Designation:		
--	Check		LAYOUT-MOTOR DRIVE-71877		Page 1 Rev. 1
Angles:	Appr.		Process	Layout.	Of 1 No. 1
--	Scale		Concept		Reg.No. 71877/1
					A3L
			© 2024 Tungaloy Corporation - Copyrights Notice		FL-40054246