

MODEL IN SCALE 3:4 TOOLS IN SCALE 1:1

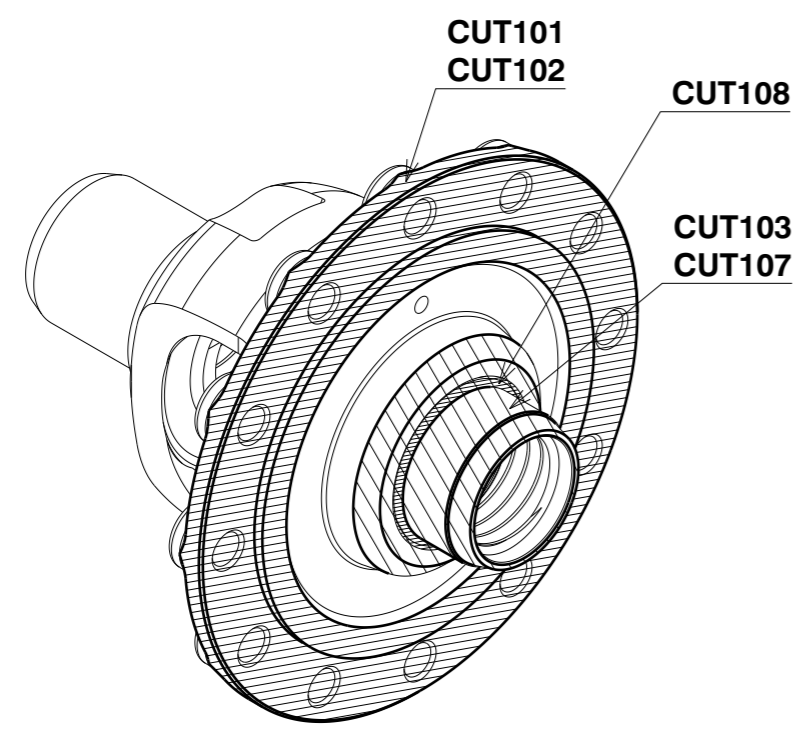

Isometric view  
Scale: 1:2

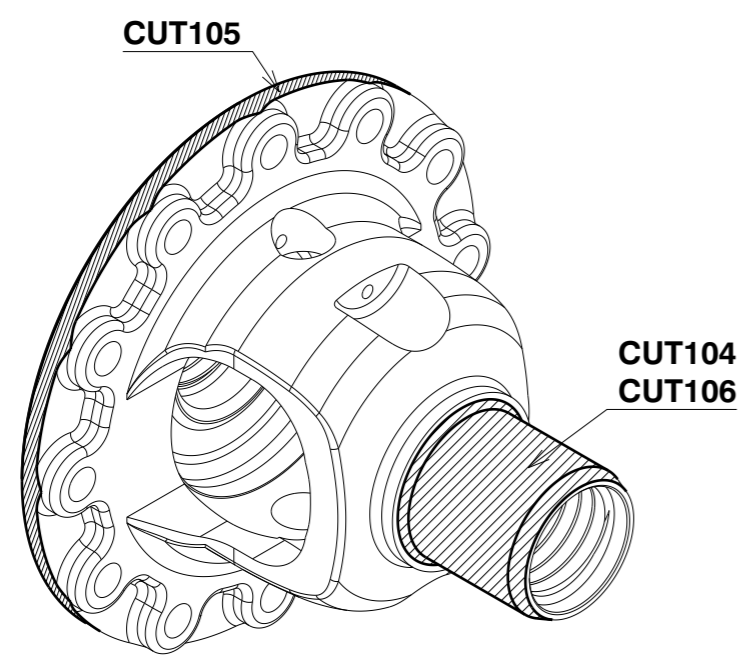

Isometric view  
Scale: 1:2

**CUT 101**  
**OD Turning Rough**  
ASBNL2525M15-A  
SNMG150616 T515

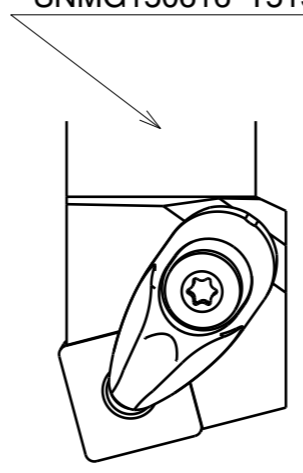

**TurningA**  
**T515**

**CUT 102/104**  
**OD Turning Rough**  
ACLNL2525X-12-CHP-MC  
CNMG120416 T515

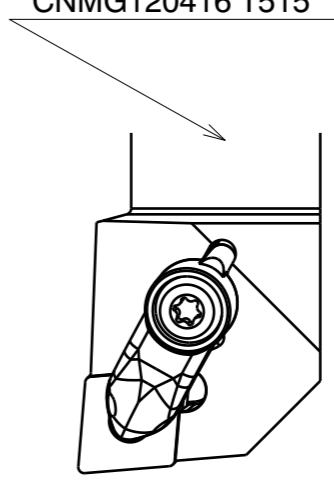

**Tung Turn-Jet**  
**T515**

**CUT 103**  
**OD Turning Rough**  
AWLNL2525X-08-CHP-MC  
WNMG080412

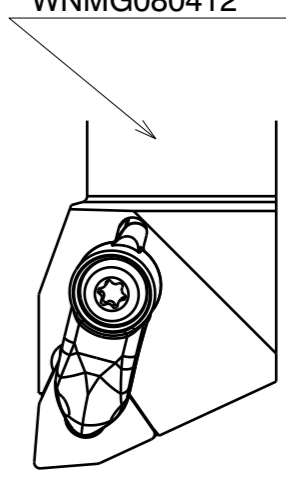

**Tung Turn-Jet**  
**T515**

**CUT 105/106**  
**OD Turning Finish**  
ADJNL2525X-15-CHP-MC  
DNMG150608-CF T5115

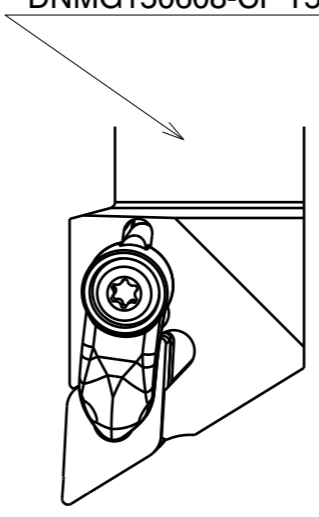

**Tung Turn-Jet**  
**T5115**

**CUT 107**  
**OD Turning Finish**  
ADJNR2525X-15-CHP-MC  
DNMG150608-CF T5115

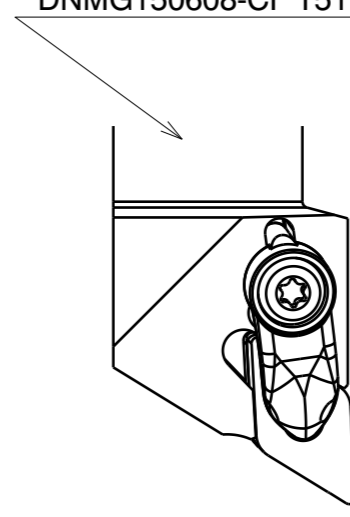

**Tung Turn-Jet**  
**T5115**

**CUT 108**  
**OD Turning Finish**  
PVQNR2525M16-CHP  
VNMG160404-CF T5115

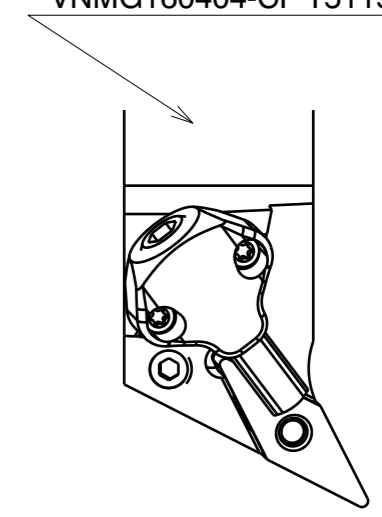

**Tung Turn-Jet**  
**T5115**

# Lathe : O.D.Turning

Unspecified Tolerances	Draw		Customer: TUNGALOY	Japan	
	Design		Designation: LAYOUT-D/F CASE-61140		
Dim.s:	Check		Process		Page 1
	Appr.		Concept		Of 1
Angles:	Scale		Layout.		Rev. No. 1
			-		Reg.No. 61140/1
© 2019 Tungaloy Corporation - Copyrights Notice			FL-40029731		A3L

MODEL IN SCALE 1:2 TOOLS IN SCALE 1:2

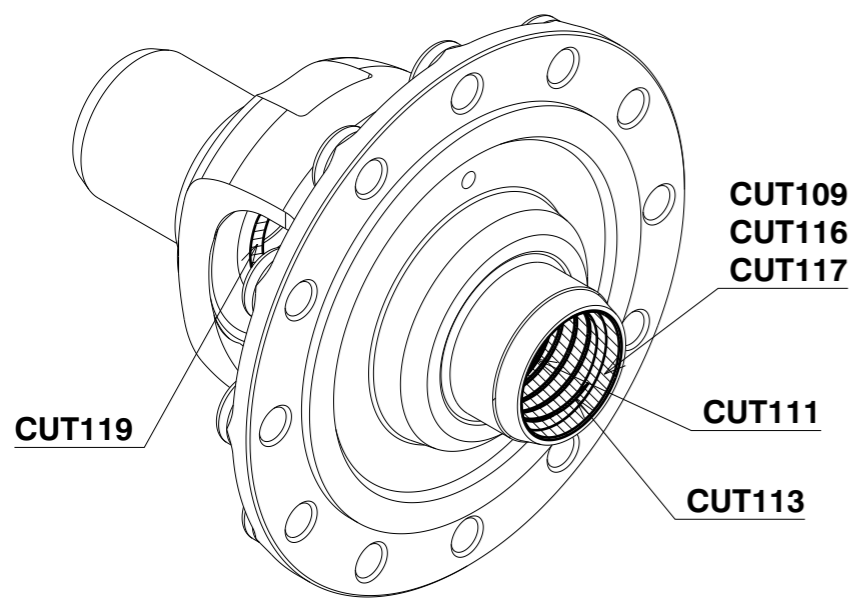

Isometric view  
Scale: 1:2

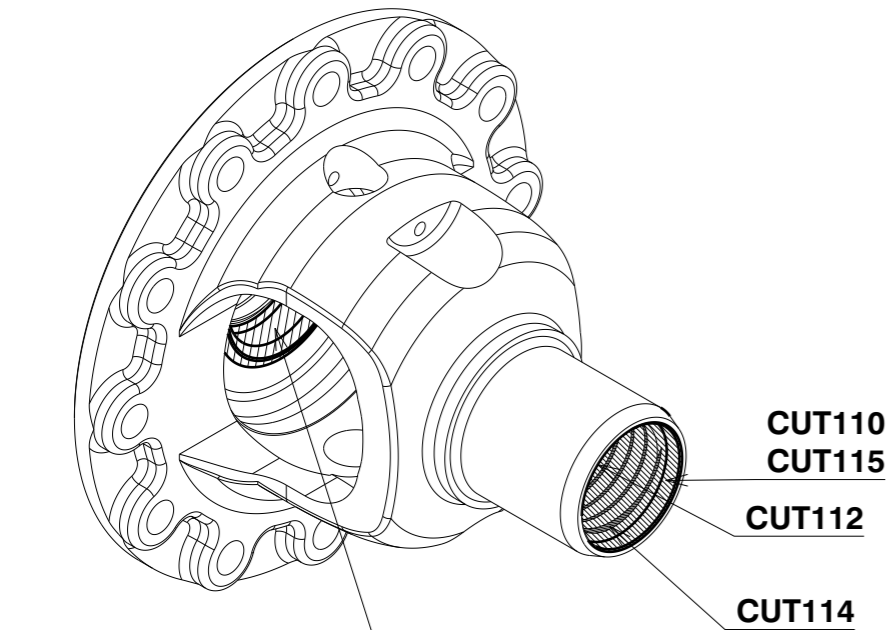

Isometric view  
Scale: 1:2

**CUT 109/110**  
**ID Turning Rough**  
KBZ-32.4L100S32 (SPECIAL)  
SPMM322ERD T313W

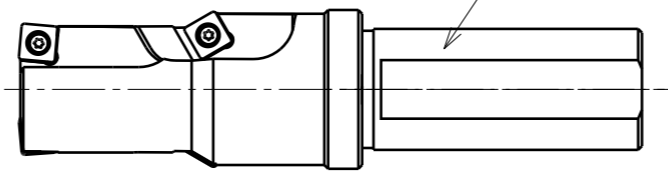

**Special Tool**

**CUT 111/112**  
**ID Turning Rough**  
A25S-SDZCL11-D250  
DCMT11T308-CM T515

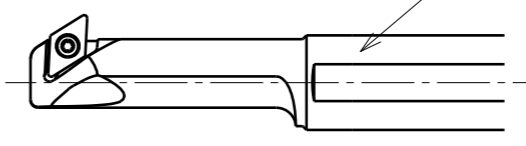

**Stream Jet Bar**

**CUT 111/112**  
**ID Turning Finish**  
D20-L200-7D-C  
S20-SDZCL11-H (SPECIAL)  
DCMT11T308-CM T515

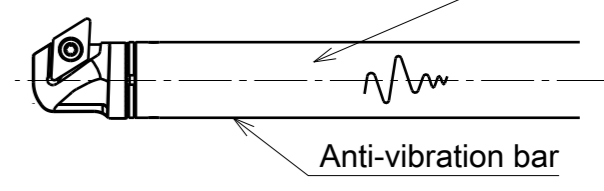

**Bore Meister**

**CUT 113/114**  
**ID Double start grooving Finish**  
KBN-31S32L130 (SPECIAL)  
Special Insert (SPECIAL)

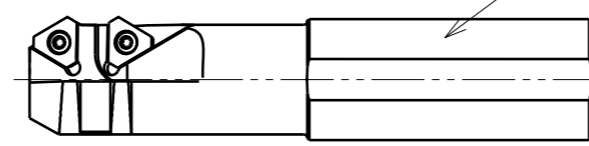

**Special Tool**

**CUT 113/114**  
**ID Grooving Finish**  
D20-L200-7D-C  
S20-SNR16-H (SPECIAL)  
16IR25ISO AH725

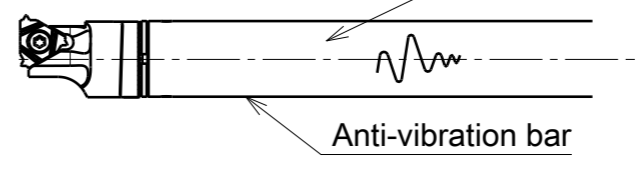

**Bore Meister**

**CUT 115/116**  
**ID Turning Finish**  
D20-L200-7D-C  
S20-SDUCL11-H  
DCMT11T308-CM T515

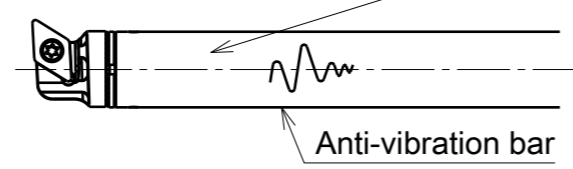

**Bore Meister**

**CUT 117**  
**ID Turning Finish**  
D20-L200-7D-C  
S20-SDNCN11-H (SPECIAL)  
DCMT11T308-CM T515

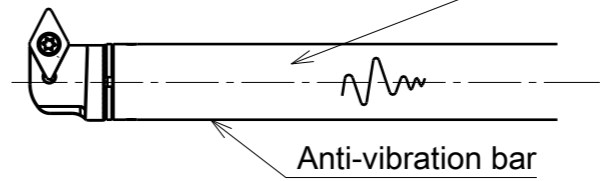

**Bore Meister**

**CUT 118/119**  
**ID Turning Finish**  
NEE-L32F18L200C(SPECIAL)  
CPMT090308-CM T515

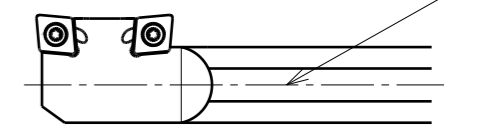

**Special Tool**

# Lathe :I.D.Turning

Unspecified Tolerances	Draw		Customer: TUNGALOY	Japan	
	Design				
Dim.s:	Check		Process	Layout.	Page 1 Of 1
	Appr.				
Angles:	Scale		-	-	Reg.No. 61140/1



MODEL IN SCALE 1:2 TOOLS IN SCALE 1:2

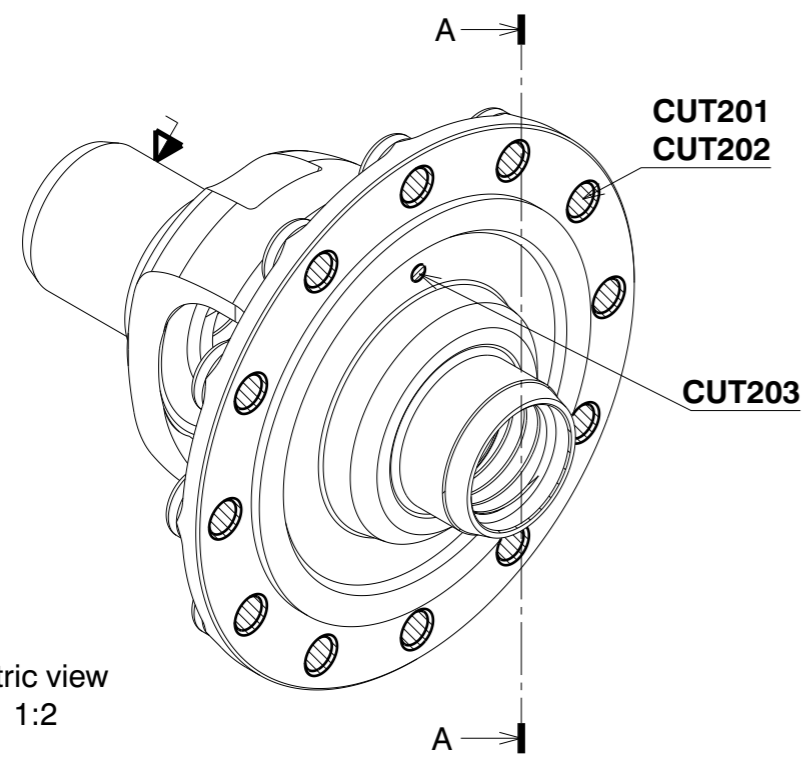

Isometric view  
Scale: 1:2

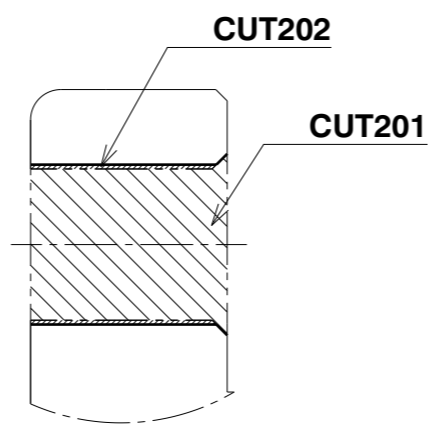

Detail B  
Scale: 2:1

**CUT 201**  
**Hole making and chamfering Finish**  
TID088L15L38S12 (SPECIAL)  
AOMT060204-C45 GH730  
DMP088 AH725

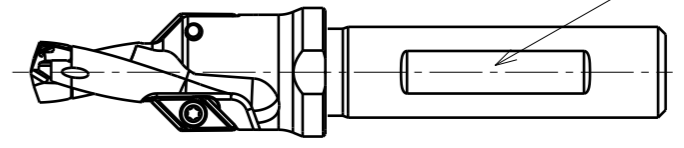

**Drill Meister**

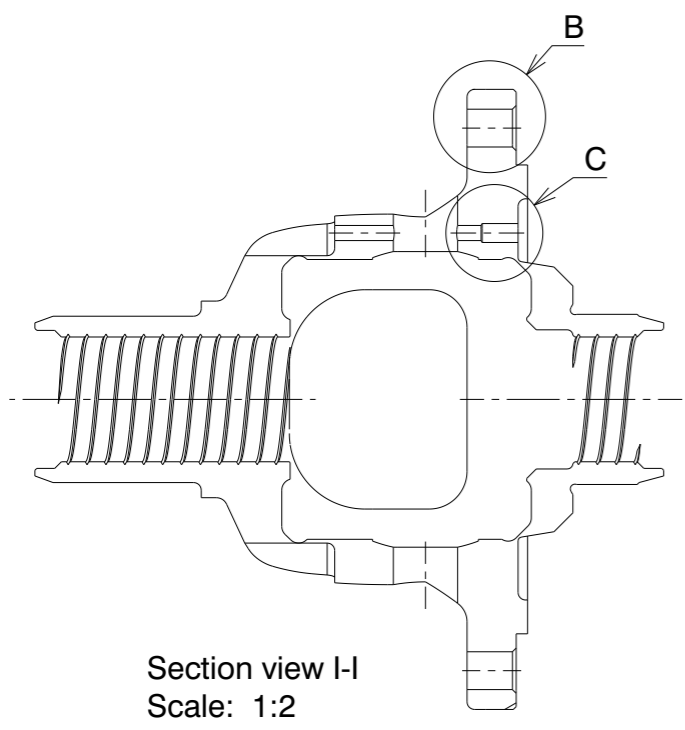

Section view I-I  
Scale: 1:2

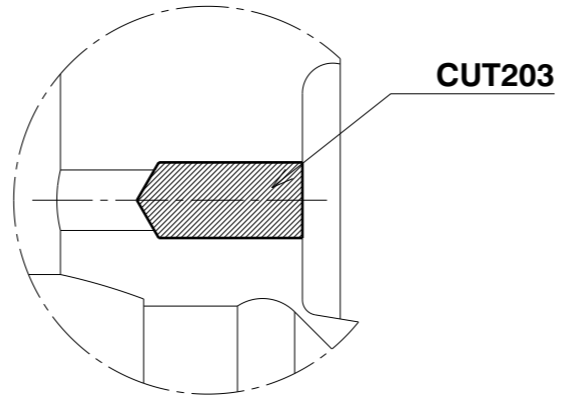

Detail C  
Scale: 2:1

**CUT 202**  
**Int. Thread milling Finish**  
MTEC0605C141.25ISO AH725

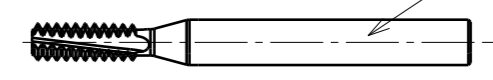

**Solid Thread**

**CUT 203**  
**Hole making Finish**  
DSW050-020-06DE3 AH725

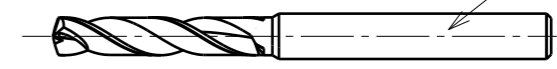

**Solid Drill**

# M/C : Hole making

Unspecified Tolerances	Draw		Customer: TUNGALOY	Japan	
	Design				
Dim.s:	Check		LAYOUT-D/F CASE-61140	Layout.	32447616-HC2
	Appr.				Process
Angles:	Scale		Concept		
			FL-40029731	Reg. No.	61140/1
© 2019 Tungaloy Corporation - Copyrights Notice					A3L

MODEL IN SCALE 1:2 TOOLS IN SCALE 1:1

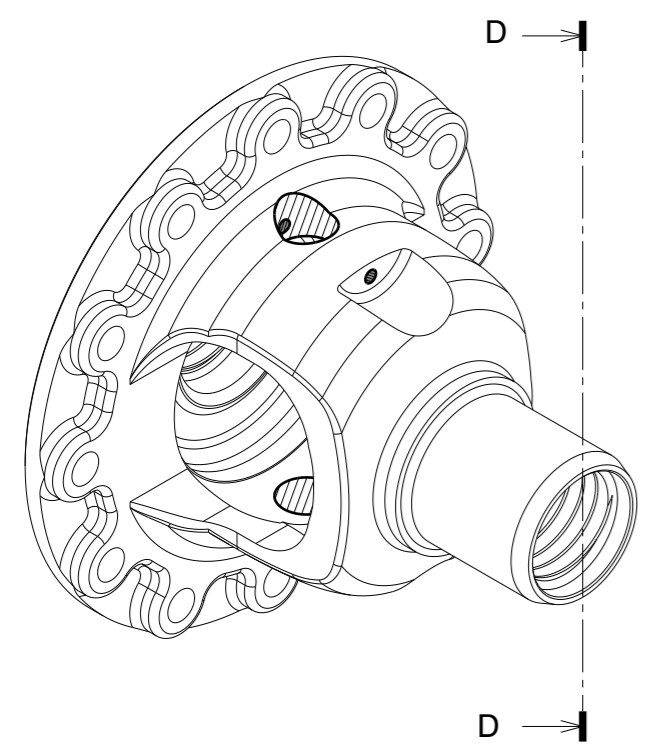

Isometric view  
Scale: 1:2

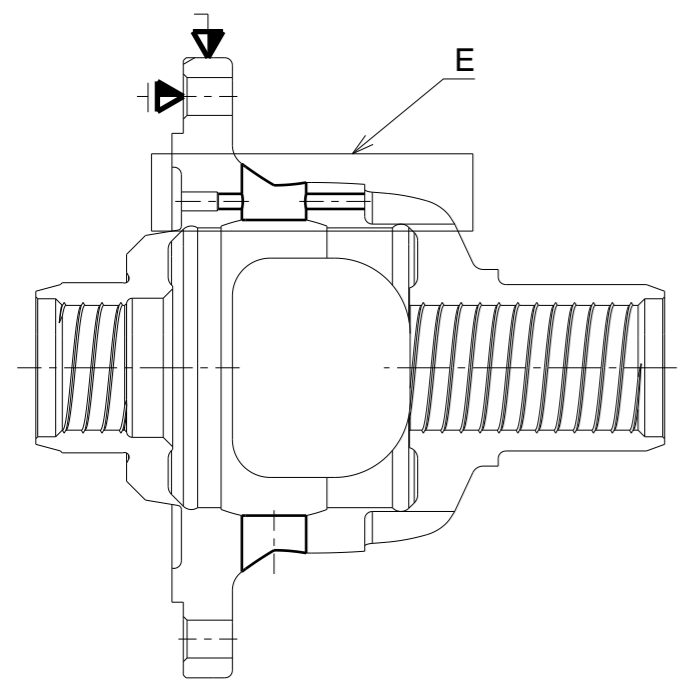

Section view D-D  
Scale: 1:2

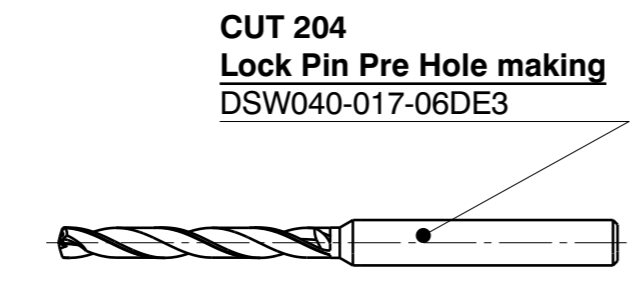

**CUT 204**  
**Lock Pin Pre Hole making**  
DSW040-017-06DE3

**Solid Drill**

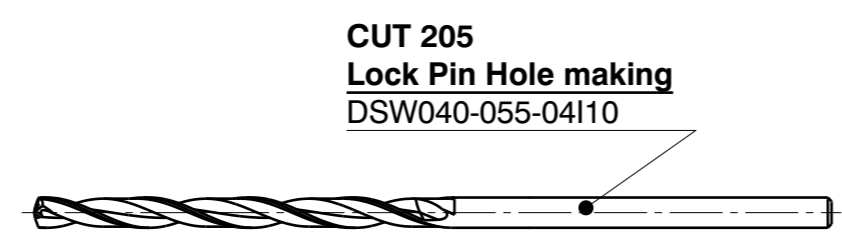

**CUT 205**  
**Lock Pin Hole making**  
DSW040-055-04110

**Solid Drill**

**CUT 206**  
**Pinion Counter Boring**  
VSSD16L100S10-S  
VGC160L15.0R08-02S10 AH725

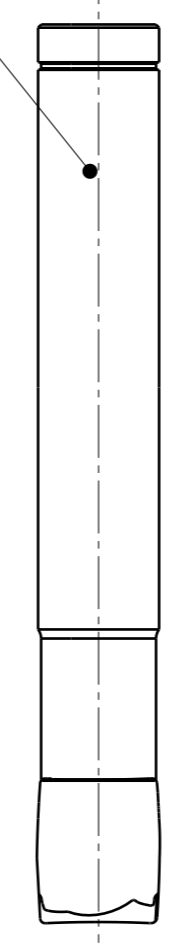

**Tung Meister**

**CUT 207**  
**Pinion Pre Hole making**  
TID160F20-3  
DMP166 AH725

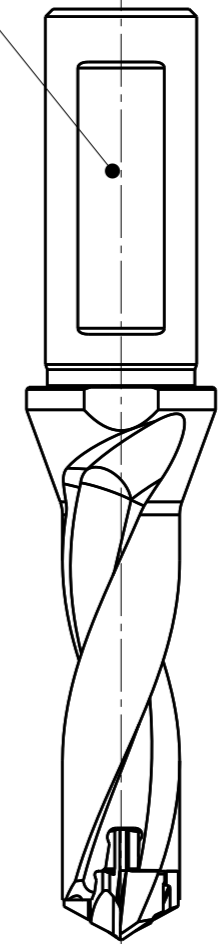

**Drill Meister**

**CUT 208**  
**Pinion Pre Hole making**  
TRM-T7-R20-3  
HRM-17.000-BL-T7 AH725

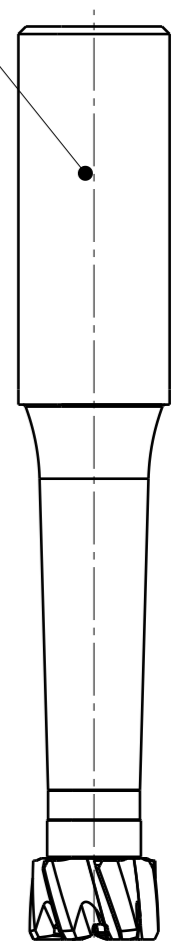

**Ream Meister**

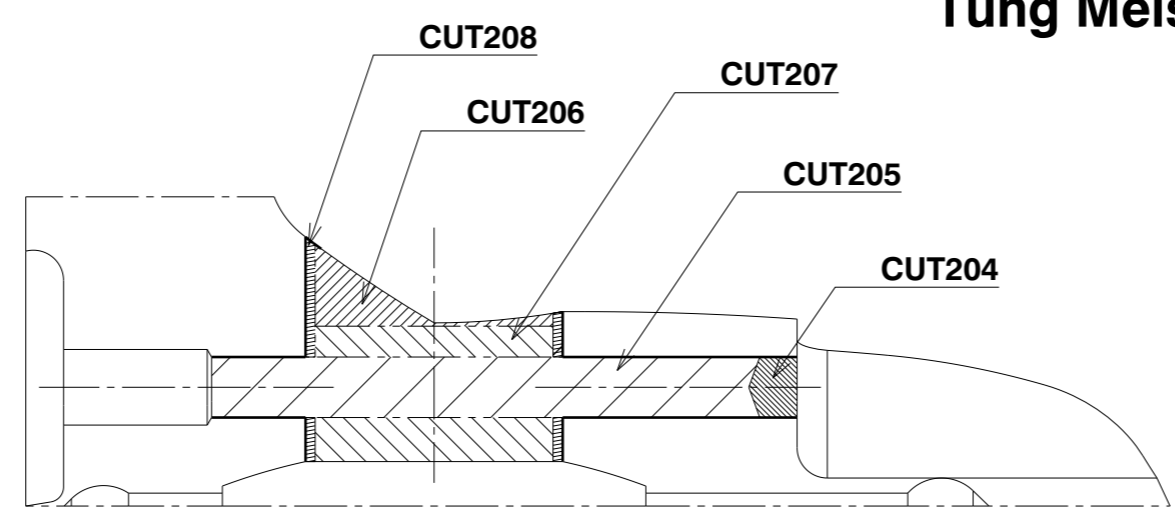

Detail E  
Scale: 2:1

# M/C : Hole making

Unspecified Tolerances	Draw		Customer: TUNGALOY	Japan	
	Design				
Dim.s:	Check		Process	Layout.	Page 1 Of 1
	Appr.				
Angles:	Scale		-		Reg. No. 61140/1
			FL-40029731		



MODEL IN SCALE 1:2 TOOLS IN SCALE 1:2

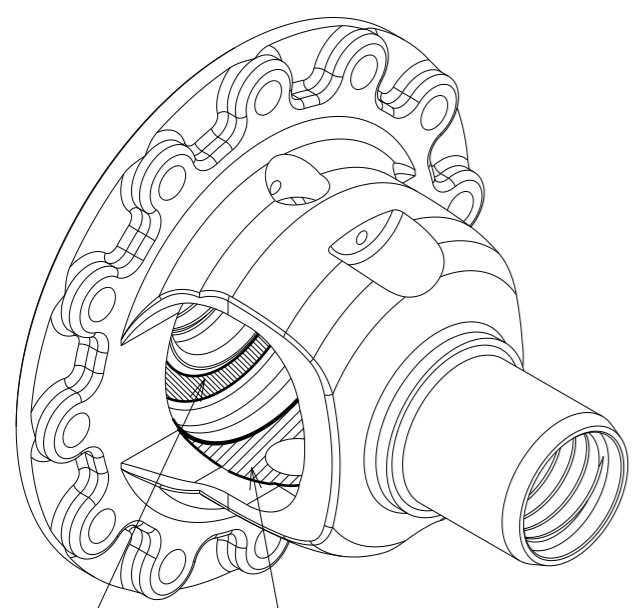

CUT210 CUT209

Isometric view  
Scale: 1:2

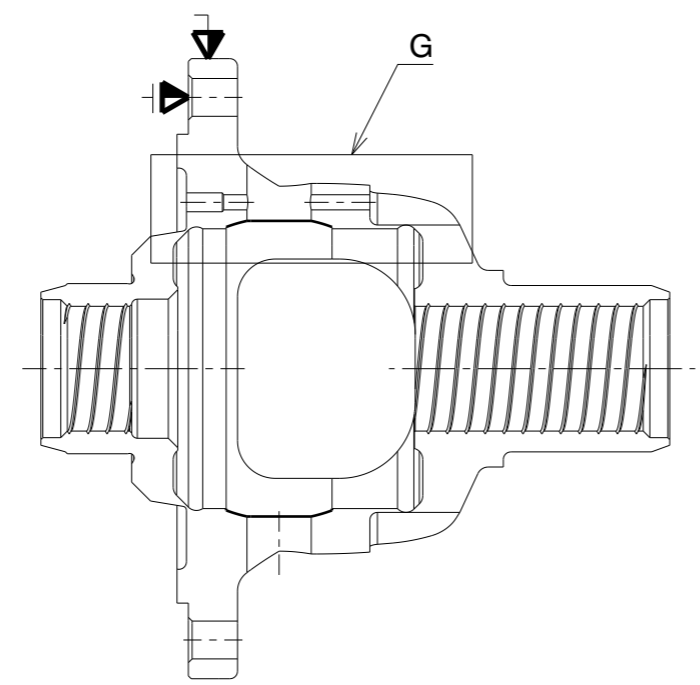

Section view F-F  
Scale: 1:2

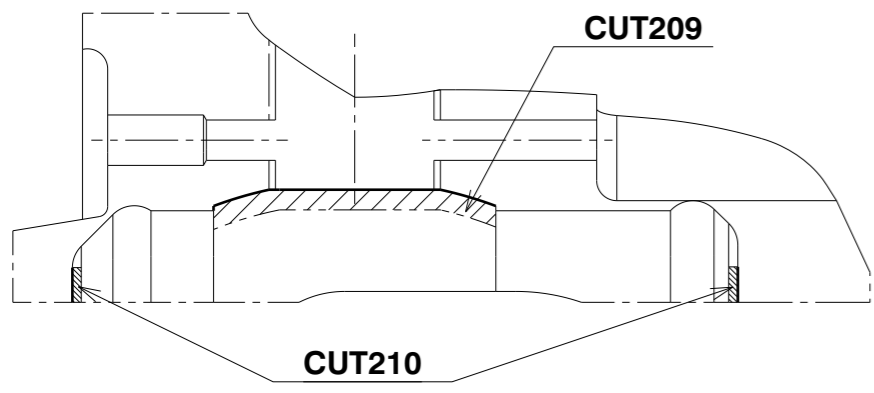

Detail G  
Scale: 4:3

**CUT 209**  
**Spherical surface milling Finish**  
KYUMEN-CUTTER  
DRIVE-KEY-A  
DRIVE-KEY-B  
INSERT-KYUMEN-R  
INSERT-KYUMEN-L

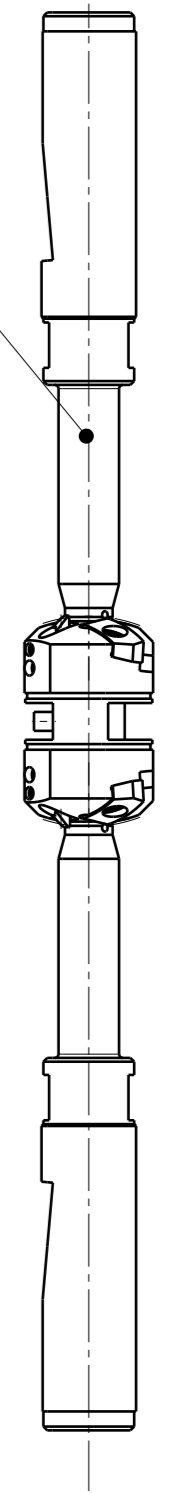

**Special Tool**

**CUT 210**  
**Flat surface milling Finish**  
HEIMEN-CUTTER  
DRIVE-KEY-A  
DRIVE-KEY-B  
INSERT-HEIMEN-R  
INSERT-HEIMEN-L

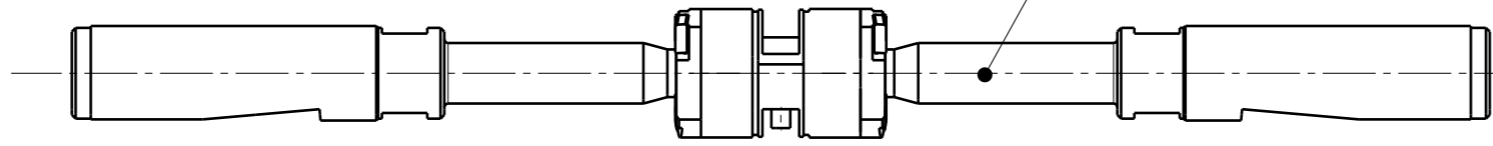

**Special Tool**

**M/C : Sphrical, Flat surface milling**

Unspecified Tolerances	Draw		Customer: TUNGALOY	Japan	
	Design				
Dim.s:	Check		LAYOUT-D/F CASE-61140		32447616-HC4
	Appr.		Process	Layout.	Page 1
Angles:	Scale		Concept		Rev. No. 1
			FL-40029731		Reg. No. 61140/1
					A3L