

Exchangeable head drill

DRILLMEISTER / **ADD M** DRILL

Tungaloy Report No. 412-G

Exchangeable head drill system for superior drilling performance and long tool life



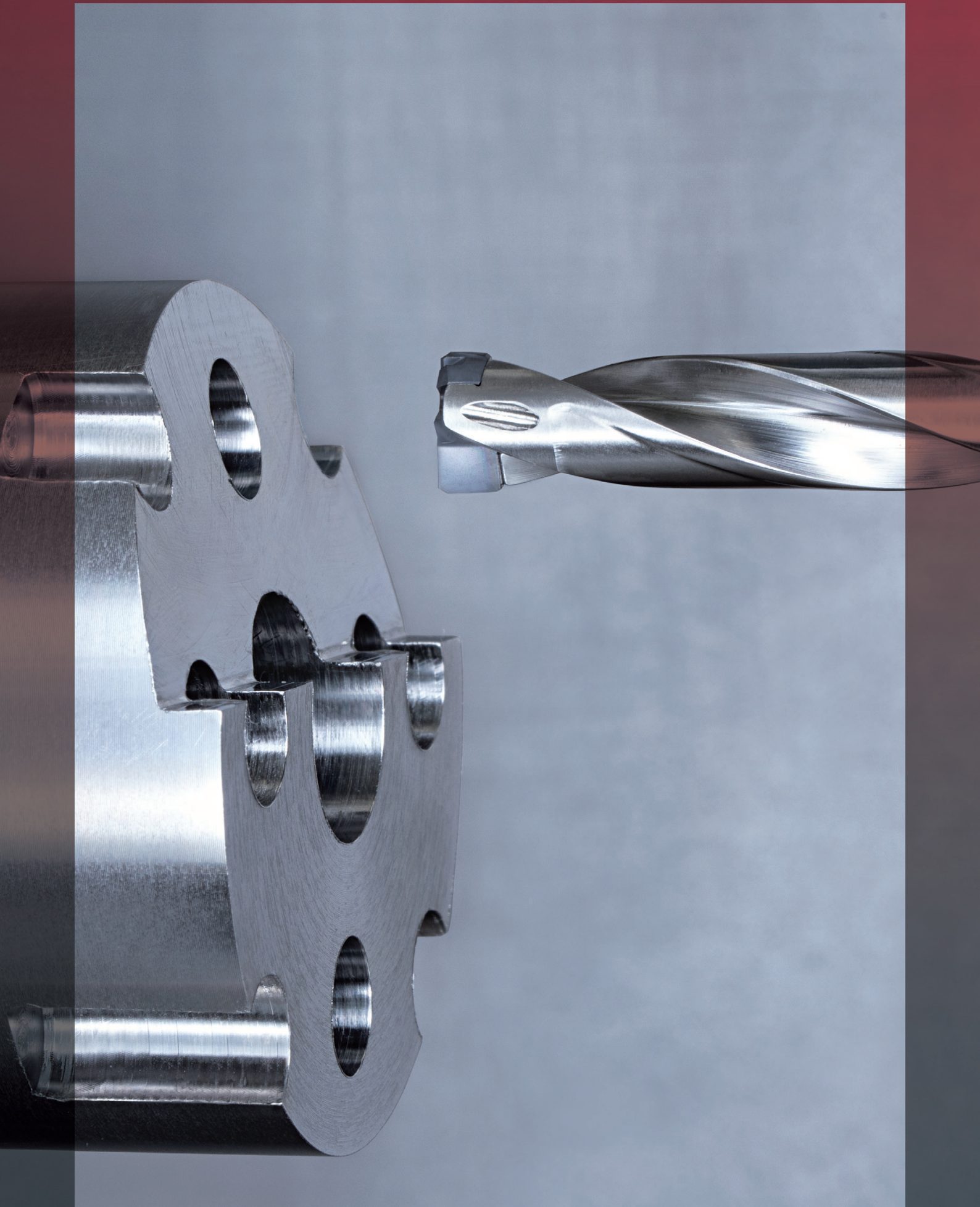

INDUSTRY 4.0
FEED the SPEED!



DRILLMEISTER / ADD MEISTER DRILL

04 General Features

07 New **AddMeisterDrill**

08 Selection Guide

08 Drill Bodies

09 Drill Heads

12 Drill Head Geometries

19 Line Up

19 Drill Bodies

33 Drill Heads

42 Technical Guide

45 Practical Examples

Exchangeable head drills for unparalleled tool life and machining performance

- Helical margin to prevent chip adhesion between the body and the hole during machining
- Tool body made from highest grade of steel with superior hardness for high wear resistance
- Wide variety of geometries for every drilling application
- Advanced grade options ensure stable, long tool life
- Internal coolant channels supply efficient cooling and lubrication during the drilling process

New
ADDMEISTERDRILL
 Tool diameter: $\varnothing 4 - \varnothing 5.9$ mm

DRILLMEISTER
 Tool diameter: $\varnothing 6 - \varnothing 25.9$ mm

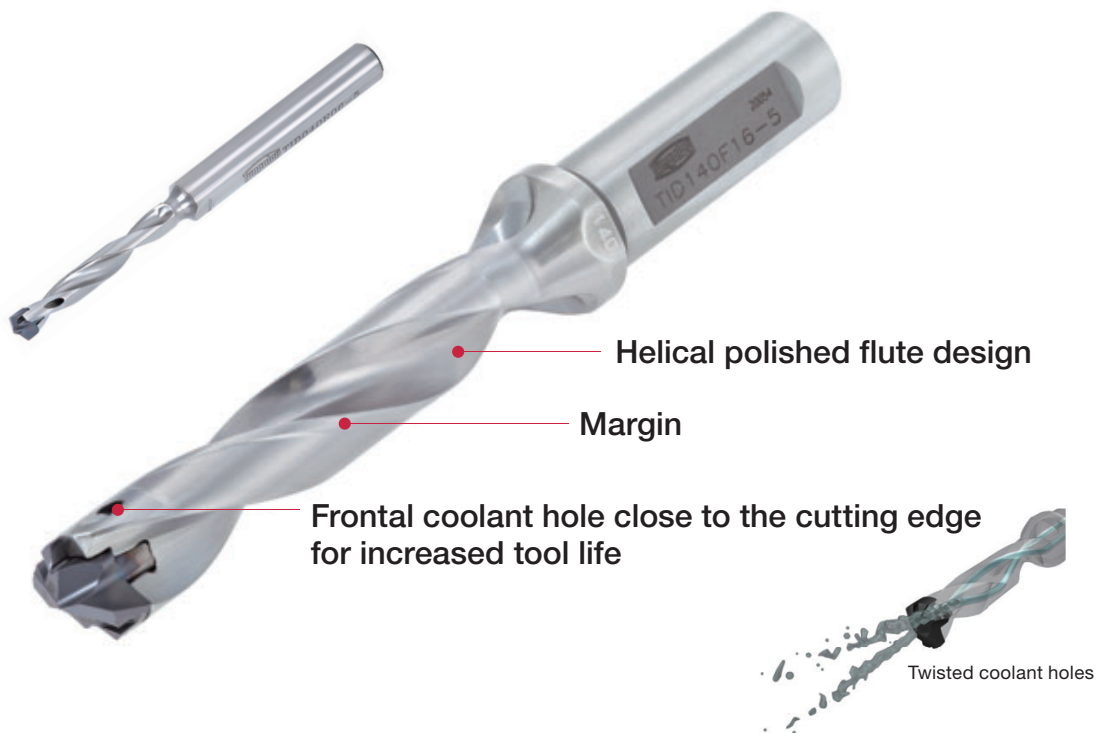

Anti pull-out feature

Dove-tail groove

Axial stopper

Clamping area

Radial stopper

Quick and precise head changing with advanced self-clamping system

- Drilling head pocket designed to withstand high machining cutting conditions
- Allows easy and fast head indexing, minimizing machine downtime

■ A single drill body can hold a range of drill heads with various geometries and sizes. Drill heads are available in 0.1 mm increments.

DMP



General use for any type of material. Low cutting force.

DMC



High accuracy drilling by quick self centering design.

DMF



Flat edge design with self centering edge. Flat bottom.

DMH



Reinforced edge design to prevent corner fracture.

DMN



Non-coated sharp edge design for non-ferrous metals.

50

drilling possibilities per drill body



5 different geometries are available, and each drill body can fit 10 different drill head sizes

TID-F type

Flange type
1.5xD, 3xD, 5xD, 8xD



TID-R type

Round shank type
2xD, 3xD, 3.5xD, 5xD, 6xD, 8xD, 12xD



TIDC / TIDCF type

Straight flute type
3xD, 5xD can be mounted in chamfer holder TIDCF



■ Tool body variations

TID-F... type

- Constant tool length due to flange support
- Flat for side-lock clamping



TID-R... type

- Tool overhang to be adjusted more freely within shank length
- Perfectly suitable for hydro holders



TID-R..E type

- Economical option for external coolant environment
- Tool overhang to be adjusted more freely within shank length



TIDC type

- Tools have peripheral flats for correct clamping of the chamfering inserts when assembled with TIDCF holder
- Flat for side-lock clamping



■ Drilling and chamfering in one shot

Three different chamfering angles are available on the same holder.

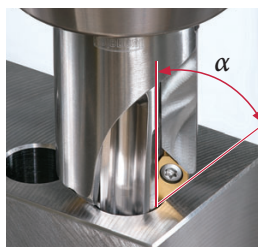

$\alpha = 60^\circ$



$\alpha = 45^\circ$



$\alpha = 30^\circ$



Adjustable

TIDCF

World's smallest exchangeable drill head series

Now available in $\varnothing 4$ mm to $\varnothing 5.9$ mm diameters with 0.1 mm increments



New

- Smallest exchangeable head diameter down to 4 mm
- Minimize tool set up time with a dedicated key (attached to every head)
- Efficient coolant supply - excellent chip evacuation + long & stable tool life
- Every tool can be mounted on 0.5 mm range of heads



Quick and easy clamping with unique key supplied with each head



Assembled drill head within key



Twisted internal coolant holes promote efficient chip evacuation and longer tool life

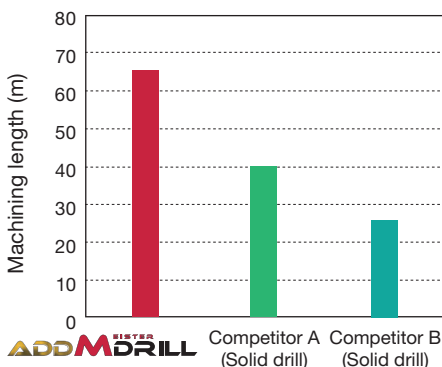

P

Tool : $\varnothing 5$ mm, L/D = 5
 Drill head : DMP050
 Grade : AH725
 Workpiece material : SCM440 / 42CrMo4 (270HB)
 Cutting speed : $V_c = 100$ m/min
 Feed : $f = 0.1$ mm/rev
 Hole depth : $H = 20$ mm
 Coolant : Wet

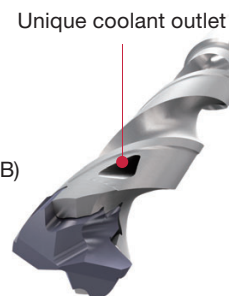

DRILL BODY SELECTION GUIDE

● TID type

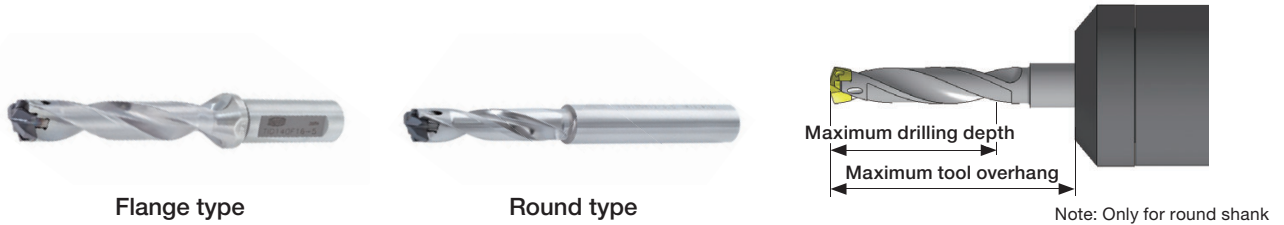

Maximum drilling depth	Maximum tool overhang	Shank type	Drill diameter range (mm)	Tool holder					Page
				Hydro chuck	Collet chuck	Power chuck	Side lock	Side lock sleeve	
1.5xD	-	Flange	ø6 - ø25.9		○	○	○	○	20
2xD	4xD	Round	ø6 - ø16.9	○	○	○			24
3xD	-	Flange	ø6 - ø25.9		○	○	○	○	21
	4xD	Round	New ø4 - ø5.9	○	○	○			19
3.5xD	6xD	Round	ø6 - ø19.9	○	○	○			25
5xD	-	Flange	ø6 - ø25.9		○	○	○	○	22
	6xD	Round	New ø4 - ø5.9	○	○	○			19
6xD	9xD	Round	ø6 - ø19.9	○	○	○			26
8xD	-	Flange	ø7 - ø25.9		○	○	○	○	23
	11xD	Round	ø6 - ø19.9	○	○	○			27
12xD	-	Round	ø8 - ø25.9	○	○	○			28











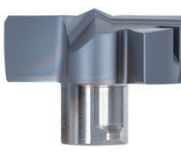

● TIDC type



Maximum drilling depth	Maximum tool overhang	Shank type	Drill diameter range (mm)	Tool holder					Page
				Hydro chuck	Collet chuck	Power chuck	Side lock	Side lock sleeve	
3xD	-	Round	ø7.5 - ø19.9		○	○	○	○	29
5xD	-	Round	ø7.5 - ø19.9		○	○	○	○	30

DRILL HEAD SELECTION GUIDE

● : Possible to drill without pre-hole
 ○ : Pre-hole operation is recommended
 ★ : First choice
 ☆ : Second choice

		General	High accuracy drilling Deep drilling	Flat drill with pilot edge	Reinforced design	Non-ferrous metal
Head						
		DMP	DMC	DMF	DMH	DMN
Drill diameter range (mm)		4 - 25.9	4 - 25.9	6 - 25.9	6 - 25.5	10 - 19.9
Workpiece material	P Steel	★	★	★	★	
	M Stainless	★	☆	☆	☆	
	K Cast iron	★	★	★	★	
	N Non-ferrous	☆	☆	☆		★
	S Superalloys	★	★	☆	☆	
	H Hard materials	☆	☆	☆	★	
Drilling depth	1.5xD	●	●	●	●	●
	3xD	●	●	●	●	●
	5xD	●	●	●	●	●
	6xD	○	●	●	○	●
	8xD	○	●	●	○	●
	12xD	○	●	○	○	○
	IT8 - 9	☆	★			
	IT9 - 10	★	★	★	★	★
	Hole position	☆	★	☆		
	High hole straightness		★	☆		
Curvature surface			★	☆		
Flat bottom hole				★		
Uneven surface Entry / Exit		☆	☆	★		☆
Narrow depth through hole		☆	☆		★	☆
External coolant		★	☆	☆	☆	
Edge fracture					★	

● IT (International Tolerance) Grades

Basic size (mm)		International tolerance grade			
		IT7	IT8	IT9	IT10
>	≤	(μm)			
3	6	12	18	30	48
6	10	15	22	36	58
10	18	18	27	43	70
18	30	21	33	52	84

Ensures long tool life and wear predictability

Margin of DrillMeister head

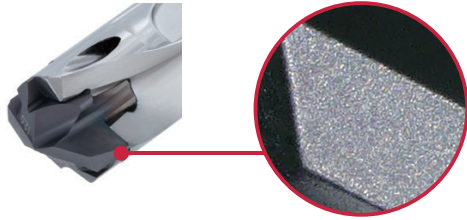

- Cutting head is always new and reliable
- Optimized coating thickness provides long tool life
- Constant coating quality provides superior tool life predictability

Margin of solid carbide drill (after reconditioning)

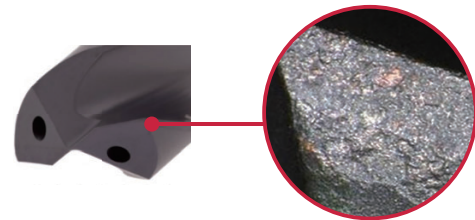

- Excess coating thickness due to multiple re-coating processes
- Fragile coating layer due to excess re-coating
- Result: unpredictable tool life

Stable tool life

Tool life fluctuations of DrillMeister

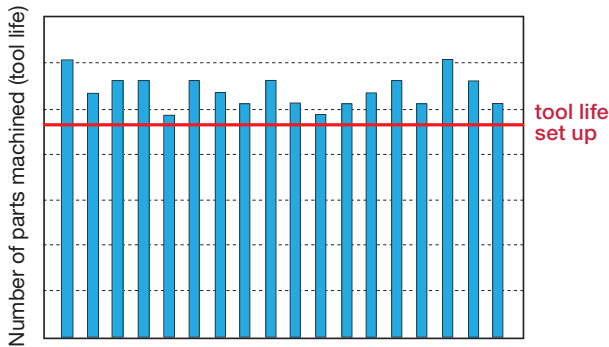

Tool life fluctuations of solid carbide drills

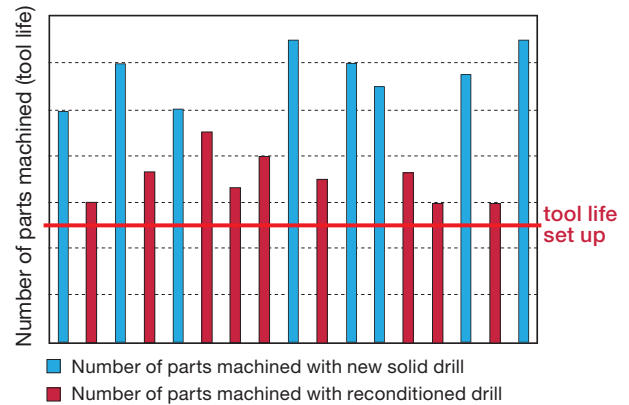

Minimizes machine downtime due to quick head exchange system

DrillMeister allows quick exchange of drill heads, while the drill body is in the machine. This eliminates the needs for tool offset after replacement, while ensuring cutting point repeatability.

DRILLMEISTER

VS

Solid drill

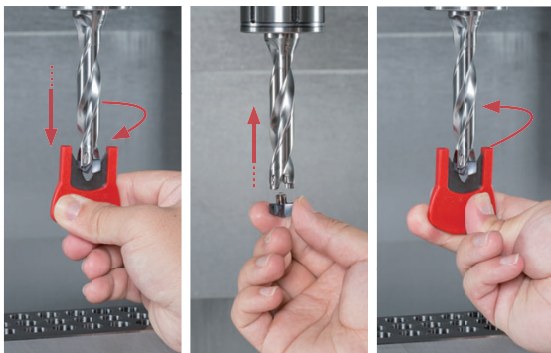

< 15 sec.

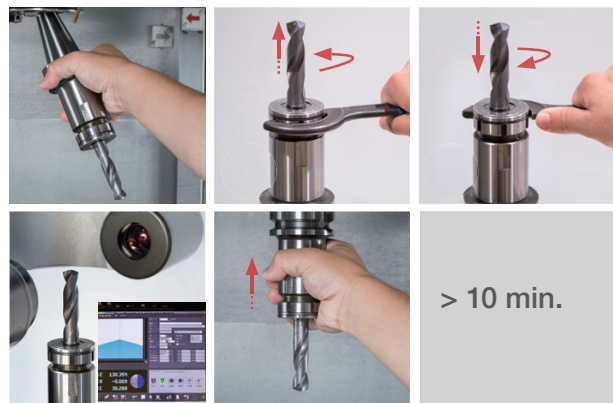

COMPARISON AGAINST OTHER TYPES OF HOLE MAKING TOOLS

	ADD M^{MASTER} DRILL DRILLMEISTER	Screw lock type Exchangeable drill	Solid carbide drill	Indexable insert type drill
Number of effective edge	2	2	2	1
Productivity	Excellent	High	High	Low
Hole diameter accuracy	IT8 - 10	IT8 - 10	IT8 - 10	IT11 - 12
Diameter variation	0.1mm increment	0.1 mm increment	0.1 mm increment	0.5 mm increment
Over 8xD drilling	Possible (with DMC head)	Pre-hole operation required	Pre-hole operation required	Special tool body required
Chip control	Excellent	Good chip control	Good chip control	Optimized by cutting condition and breaker
Hole straightness	Excellent (with DMC head)	Good	Excellent	Not good
Accessory of tool set up	Key only	Wrench and screw	-	Wrench and screw
Tool set up	15 sec.	1 min.	10 min.	5 min.
Tool position after set up	Constant	Constant	Always different	Constant
Tool life	Long and stable	Stable	After reconditioning tool life decreased by around 30%	Stable
Tool cost	Medium	Medium	High	Low
Reconditioning	None	None	Necessary	None
Inventory Management	Easy	Easy	Complex	Easy
Special diameter	Only need special drill head	Only need special drill head	Special drill body required	Special tool body required
Lathe machine	Stable	Stable	Misalignment will cause breakage	Stable

● Tailor made drill body

Special drill bodies featuring chamfering or counter boring capabilities with indexable insert and head. Reduce down time and tool management compared to solid drill.

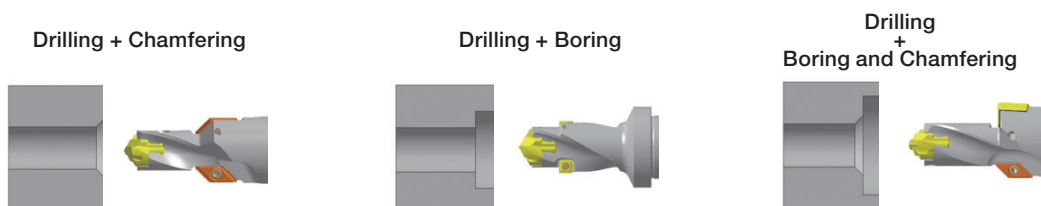

DMP - General purpose



- General drill head with 140° point angle for any type of materials
- Smooth radius edge honing provides low cutting force and long tool life

Low cutting force ensure stable drilling

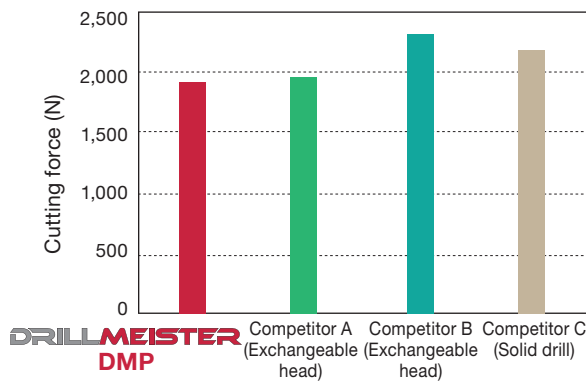

P	Tool	: $\phi 12$ mm, L/D = 3
	Drill head	: DMP120
	Grade	: AH9130
	Workpiece material	: S55C / C55
	Cutting speed	: $V_c = 120$ m/min
	Feed	: $f = 0.2$ mm/rev
	Hole depth	: $H = 30$ mm
Coolant	: Wet	

Long tool life in any type of material

Close-up of edges

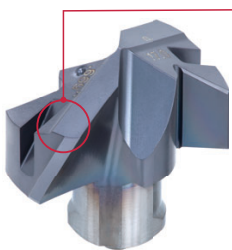

No peeling-off



Radius honing

DRILLMEISTER
DMP

Effectively improves
adhesion strength



Peeling-off

Chamfered honing

Competitor

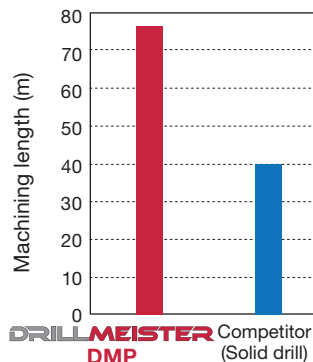

P	Tool	: TID160F20-3
	Drill head	: DMP167
	Grade	: AH9130
	Workpiece material	: S20C
	Cutting speed	: $V_c = 110$ m/min
	Feed	: $f = 0.35$ mm/rev
	Hole depth	: $H = 20$ mm
	Coolant	: Wet

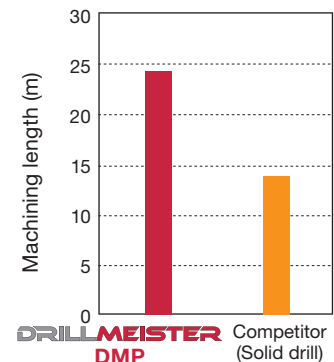

M	Tool	: TID115F16-3
	Drill head	: DMP115
	Grade	: AH9130
	Workpiece material	: SUS304 / X5CrNiMo
	Cutting speed	: $V_c = 50$ m/min
	Feed	: $f = 0.2$ mm/rev
	Hole depth	: $H = 40$ mm
	Coolant	: Wet

DMC - High accuracy drilling



- Innovative self-centering geometry for smooth drilling and accurate hole tolerance
- No pre-drilling required in 12xD drilling operation
- Double margins provides superior surface finish and hole drilling straightness

*DMC040 - 059 is single margin

Improve hole accuracy without changing cutting condition

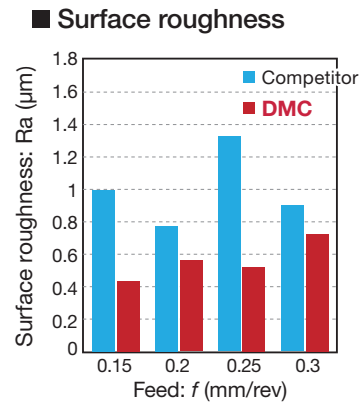
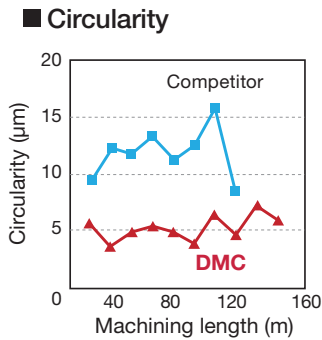
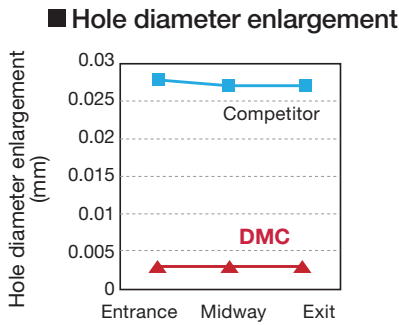

P Tool : $\phi 14$ mm, L/D = 5
 Workpiece material: S55C / C55
 Cutting speed : $V_c = 100$ m/min
 Feed : $f = 0.25$ mm/rev
 Measured at : 30 mm

Stable long drilling without pilot hole operation

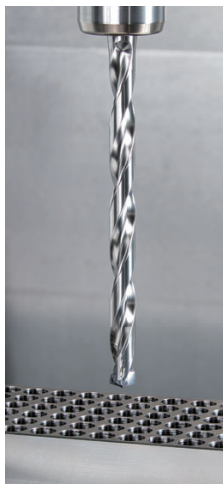

DRILLMEISTER
DMC



Competitor

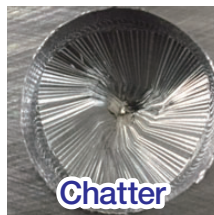

P Tool : $\phi 13$ mm, L/D = 12 (No pilot hole)
 Workpiece material : S55C / C55
 Cutting speed : $V_c = 100$ m/min
 Feed : $f = 0.3$ mm/rev

DMH - Fracture resistance head

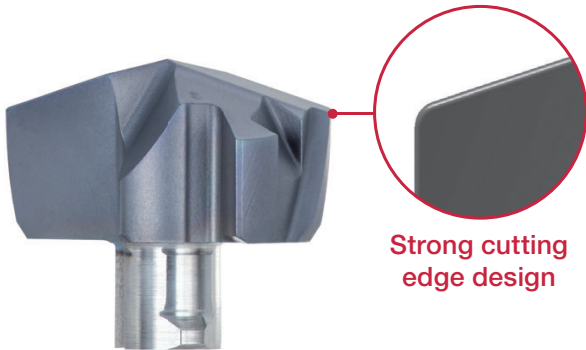

- Solution for corner edge fracture
- Reinforced drill edge design protects head's corners from both the damaging impact of the recoiling wall and weak fixture
- Ideal option for low rigidity workpiece or machine

Longer tool life without edge fracture

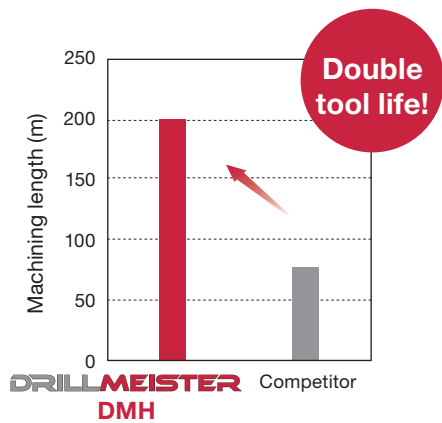

DRILLMEISTER DMH

Competitor

P

Tool : $\varnothing 13.7$ mm, L/D = 3
 Drill head : DMH137
 Grade : AH9130
 Workpiece material : High carbon steel
 Cutting speed : $V_c = 90$ m/min
 Feed : $f = 0.3$ mm/rev
 Hole depth : $H = 20$ mm
 Coolant : Wet (External)

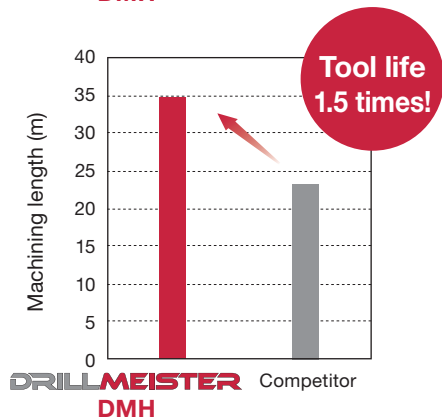

H

Tool : $\varnothing 10.2$ mm, L/D = 3
 Drill head : DMH102
 Grade : AH9130
 Workpiece material : Tool steel (40HRC)
 Cutting speed : $V_c = 54.5$ m/min
 Feed : $f = 0.18$ mm/rev
 Hole depth : $H = 23$ mm
 Coolant : Wet (Internal)

Solution for improved tool life, especially for shallow through-holes



Hub



Knuckle

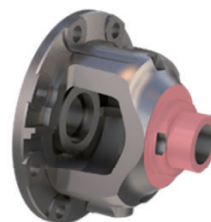

Diff. case

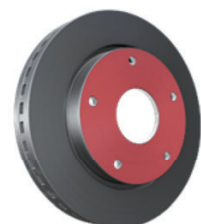

Brake disc

DMF - Flat edge design with pilot edge



- Ideal solution for counterboring, bolt heads and pre-hole of internal turning operation
- Significantly reduced radial forces ensure stable drilling for complex surfaces at drill entry and exit
- Stable drilling with long overhang up to 8xD without pre-hole

■ Solution for complex hole making processes

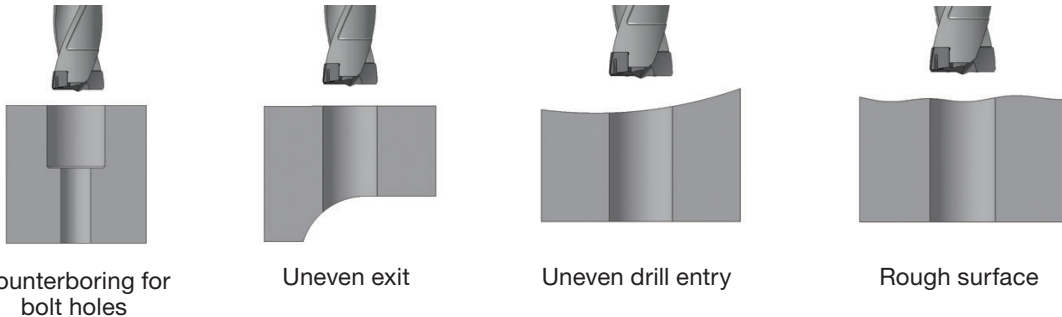

■ Stable tool life in uneven surface entry and exit

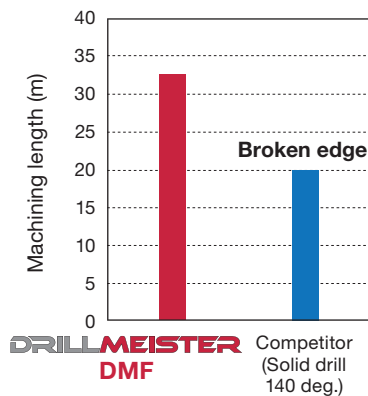

K	Tool	: $\varnothing 12.6$ mm, L/D = 3.5
	Drill head	: DMF126
	Grade	: AH9130
	Workpiece material	: FCD450 / GGG45 / 450-10S
	Cutting speed	: $V_c = 60$ m/min
	Feed	: $f = 0.3$ mm/rev / Exit: 0.06 mm/rev
	Hole depth	: $H = 46$ mm
	Coolant	: Wet



■ Ideal option for pre-hole for internal turning

Use a DMF drill head to create a starter hole for internal turning. Its flat edges leave consistent and minimum stock to remove, compared with solid carbide drills with an angled tip, for the following finishing process.

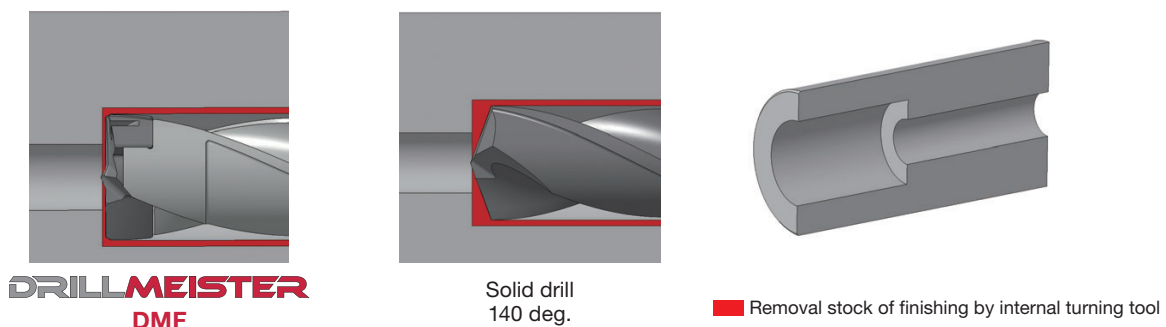

DMN - Sharp edge design for non-ferrous metals



Sharp and uncoated cutting edge design prevents built-up edge and provides good chip evacuation during drilling of non-ferrous metal.

CHIP CONTROL



Aluminium alloy
(A5052)



Aluminium alloy casting
(ADC12)

N

Tool : $\varnothing 13.7$ mm, L/D = 5
 Drill head : DMN137
 Grade : KS15F
 Cutting speed : $V_c = 200$ m/min
 Feed : $f = 0.4$ mm/rev
 Hole depth : $H = 40$ mm
 Coolant : Wet

Tailor made drill head

- Special drill diameter size 0.01 mm increments can be produced upon request by each type of head
- Special edge design can be produced upon request

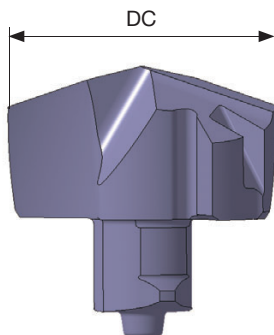

Ex. DMP1902 AH9130 ($\varnothing 19.02 + 0.018 / 0$)
 DMC1332 AH9130 ($\varnothing 13.32 + 0.018 / 0$)
 DMF0928 AH9130 ($\varnothing 9.28 + 0.018 / 0$)

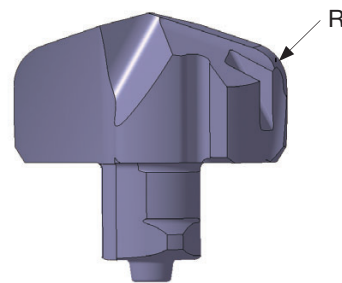

Ex. Radius shoulder design

GRADES

Latest coating optimized for extended tool life

AH9130

- Unique nano-multilayered coating is made possible by Tungaloy's latest coating technology, providing 3 principal features
- This coating achieves highly-balanced wear resistance and chipping resistance, also has acid resistance, resistance to dissolution, and high adhesion strength

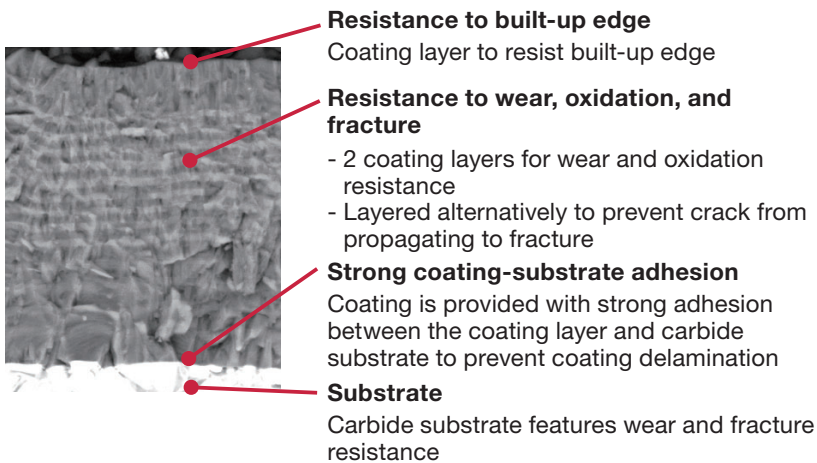

Tool life machining carbon steel (S55C / C55)

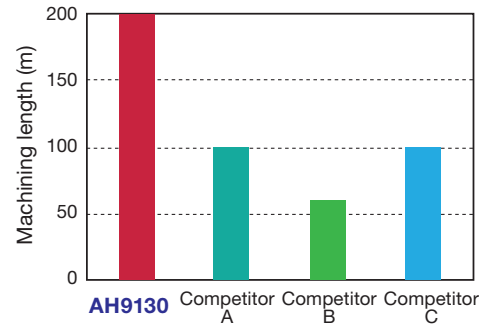

P Tool : ϕ 14 mm, L/D = 5
Cutting speed : $V_c = 100$ m/min
Feed : $f = 0.25$ mm/rev
Hole depth : $H = 60$ mm (Blind hole)

AH725 PREMIUMTEC

Reliable PVD grade is suitable for various materials

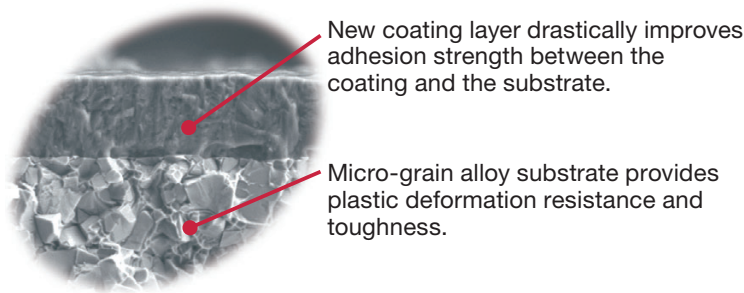

Tool life machining carbon steel (S55C / C55)

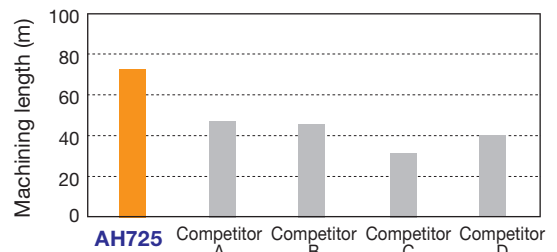

P Tool : ϕ 12 mm, L/D = 3
Cutting speed : $V_c = 100$ m/min
Feed : $f = 0.25$ mm/rev
Hole depth : $H = 36$ mm (Blind hole)

Super flash coating

"Premiumtec" improves overall coating surface quality

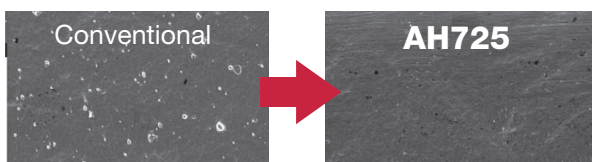

Tool life machining ductile cast iron (FCD600 / GGG60 / 600-3)

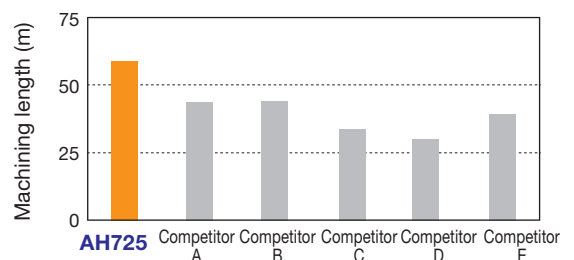

K Tool : ϕ 12 mm, L/D = 3
Cutting speed : $V_c = 150$ m/min
Feed : $f = 0.25$ mm/rev
Hole depth : $H = 36$ mm (Blind hole)

DrillMeister ensures perfect drilling for improved productivity

Case 1 Switch from solid drill

- Low cutting force drill head and optimal tool length ensures higher productivity
- Stable long tool life without expensive reconditioning cost

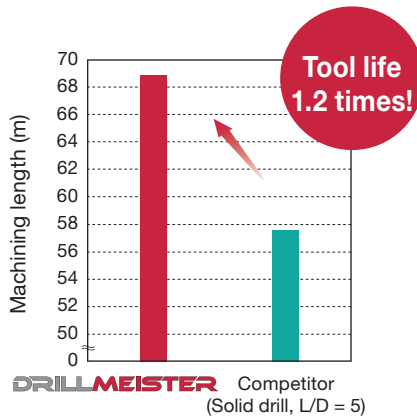
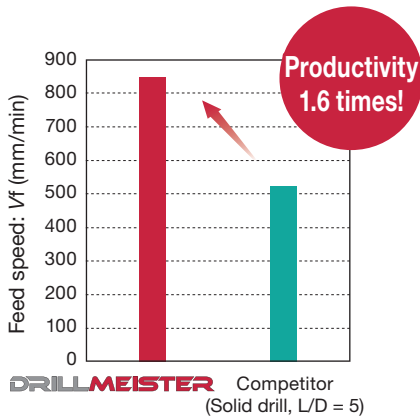

P

Tool	: TID090R10-3.5
Drill head	: DMP090
Grade	: AH9130
Workpiece material	: SS400 / E275A
Cutting speed	: $V_c = 120$ m/min
Feed	: $f = 0.2$ mm/rev
Hole depth	: $H = 23$ mm
Hole type	: Through
Coolant	: Wet

Case 2 Switch from indexable drill

- Better hole diameter accuracy
- High feed drilling improves productivity

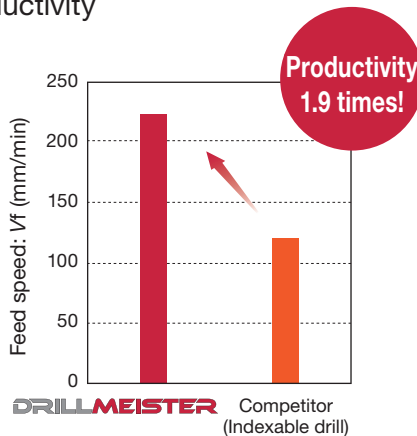
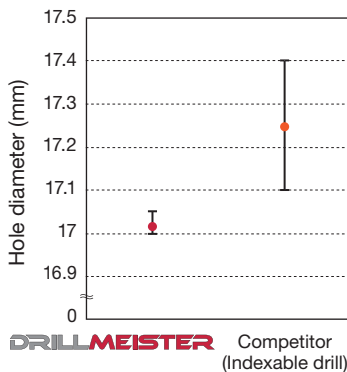

P

Tool	: TID170F20-5
Drill head	: DMF170
Grade	: AH9130
Workpiece material	: S45C / C45
Cutting speed	: $V_c = 80$ m/min
Feed	: $f = 0.24$ mm/rev
Hole depth	: $H = 82$ mm
Hole type	: Through
Coolant	: Wet

Case 3 Switch from screw lock type head changeable drill

- Simple self clamping system improves your workability
- Accurate clamping system improves tool life due to good run-out
- Combination with variety of head improves hole quality and stability

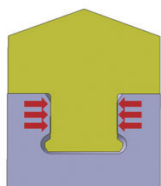

- Balanced clamping force
- Better run-out
- Wide contact area

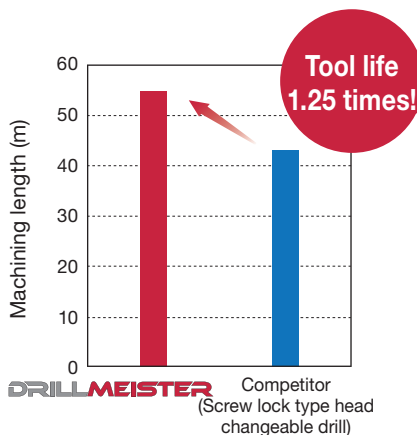

P

Tool	: TID130F20-5
Drill head	: DMC130
Grade	: AH9130
Workpiece material	: S48C / C48
Cutting speed	: $V_c = 75$ m/min
Feed	: $f = 0.27$ mm/rev
Hole depth	: $H = 42$ mm
Hole type	: Through
Coolant	: Wet

DRILL BODY

New

TID-R L/D=3

Exchangeable head drill

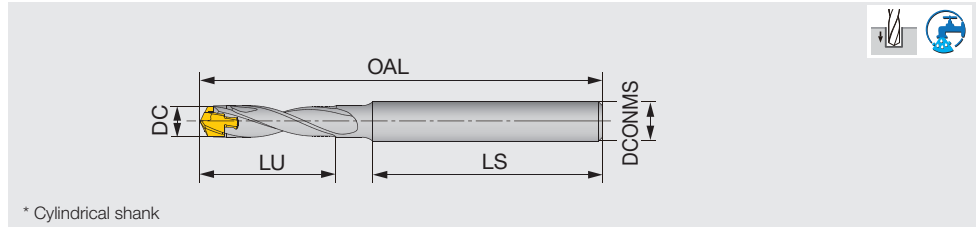

* Cylindrical shank

Designation	DC	DCONMS	LU	LS	OAL		Pocket size	Head
					DMP	DMC		
TID040R06-3	4 - 4.4	6	13	35	57.7	58.1	4	DM*040 - DM*044
TID045R06-3	4.5 - 4.9	6	14	35	59.7	59.9	4.5	DM*045 - DM*049
TID050R06-3	5 - 5.4	6	16	35	61.4	61.8	5	DM*050 - DM*054
TID055R06-3	5.5 - 5.9	6	17	35	64	64.3	5.5	DM*055 - DM*059

Tool diameter	Hole diameter tolerance*
ø4 - ø5.9	IT9 - 10

*Just for reference

- An overall length (OAL) differs based on each head geometry.
- When using the drill at a higher feed rate, make sure to provide an axial support by placing the overhang adjusting screw at the drill shank end in the tool holder. This will prevent high thrust force from pushing the drill back into the holder during drilling.
- When axially adjusting the shank inside the holder to obtain a required drill overhang, make sure the shank length remaining inside the holder does not come short of the minimum clamping length (LSCN) specified by the holder supplier.

SPARE PARTS

Designation	Clamping key
TID040-045	K-TID4-4.99
TID050-055	K-TID5-5.99

New

TID-R L/D=5

Exchangeable head drill

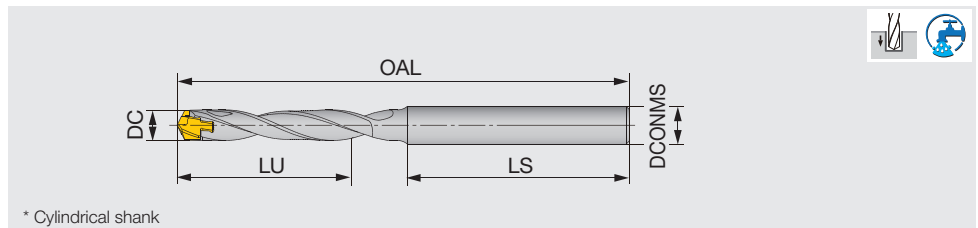

* Cylindrical shank

Designation	DC	DCONMS	LU	LS	OAL		Pocket size	Head
					DMP	DMC		
TID040R06-5	4 - 4.4	6	21	35	65.7	66.1	4	DM*040 - DM*044
TID045R06-5	4.5 - 4.9	6	23	35	68.7	68.9	4.5	DM*045 - DM*049
TID050R06-5	5 - 5.4	6	26	35	71.3	71.6	5	DM*050 - DM*054
TID055R06-5	5.5 - 5.9	6	28	35	74.2	74.5	5.5	DM*055 - DM*059

Tool diameter	Hole diameter tolerance*
ø4 - ø5.9	IT9 - 10

*Just for reference

- An overall length (OAL) differs based on each head geometry.
- When using the drill at a higher feed rate, make sure to provide an axial support by placing the overhang adjusting screw at the drill shank end in the tool holder. This will prevent high thrust force from pushing the drill back into the holder during drilling.
- When axially adjusting the shank inside the holder to obtain a required drill overhang, make sure the shank length remaining inside the holder does not come short of the minimum clamping length (LSCN) specified by the holder supplier.

SPARE PARTS

Designation	Clamping key
TID040-045	K-TID4-4.99
TID050-055	K-TID5-5.99

TID-F L/D=1.5

Exchangeable head drill

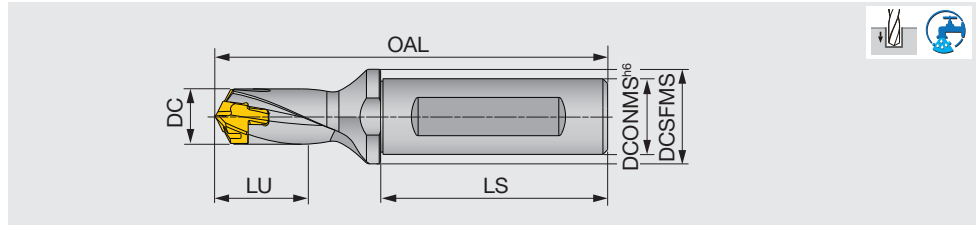

Designation	DC	DCONMS	DCSFMS	LU	LS	OAL			Pocket size	Head
						DMP/H/N	DMC	DMF		
TID060F12-1.5	6 - 6.4	12	16	10	45	67.9	68	67	6	DM*060 - DM*064
TID065F12-1.5	6.5 - 6.9	12	16	11	45	68.9	69.1	68	6.5	DM*065 - DM*069
TID070F12-1.5	7 - 7.4	12	16	12	45	70	70.4	69.1	7	DM*070 - DM*074
TID075F12-1.5	7.5 - 7.9	12	16	13	45	70.7	71.2	69.8	7	DM*075 - DM*079
TID080F12-1.5	8 - 8.9	12	16	14	45	72.3	72.4	71.4	8	DM*080 - DM*089
TID090F12-1.5	9 - 9.9	12	16	16	45	74.2	74.3	73.1	9	DM*090 - DM*099
TID100F16-1.5	10 - 10.9	16	20	17	48	79.1	79.7	77.7	10	DM*100 - DM*109
TID110F16-1.5	11 - 11.9	16	20	19	48	81	81.6	79.4	11	DM*110 - DM*119
TID120F16-1.5	12 - 12.9	16	20	20	48	82.8	83.4	81.2	12	DM*120 - DM*129
TID130F16-1.5	13 - 13.9	16	20	22	48	84.9	85.7	83	13	DM*130 - DM*139
TID140F16-1.5	14 - 14.9	16	20	24	48	89	89.8	87	14	DM*140 - DM*149
TID150F20-1.5	15 - 15.9	20	25	26	50	96	96.9	93.9	15	DM*150 - DM*159
TID160F20-1.5	16 - 16.9	20	25	27	50	99.1	100.1	96.8	16	DM*160 - DM*169
TID170F20-1.5	17 - 17.9	20	25	29	50	102.2	103.2	99.7	17	DM*170 - DM*179
TID180F25-1.5	18 - 18.9	25	32	30	56	111.3	112.4	108.5	18	DM*180 - DM*189
TID190F25-1.5	19 - 19.9	25	32	33	56	114.3	115.4	111.3	19	DM*190 - DM*199
TID200F25-1.5	20 - 20.9	25	32	34	56	117.4	118.6	115.1	20	DM*200 - DM*209
TID210F25-1.5	21 - 21.9	25	32	36	56	120.5	121.7	118	21	DM*210 - DM*219
TID220F25-1.5	22 - 22.9	25	32	37	56	123.6	124.8	120.9	22	DM*220 - DM*229
TID230F32-1.5	23 - 23.9	32	42	39	60	130.6	132	127.8	23	DM*230 - DM*239
TID240F32-1.5	24 - 24.9	32	42	40	60	133.7	135.1	130.7	24	DM*240 - DM*249
TID250F32-1.5	25 - 25.9	32	42	43	60	136.8	138.3	133.7	25	DM*250 - DM*259

Tool diameter	Hole diameter tolerance*
ø6 - ø25.9	IT8 - 9

- An overall length (OAL) differs based on each head geometry.
 - For drill diameters from ø8 mm - ø9.9 mm, the drill shoulder to shank bottom distance when a DMC drill head is mounted is 0.3 mm shorter when compared with a DMP head of the equivalent sizes. The distances are the same for the DMC and DMP drill heads in other diameters than the above.

SPARE PARTS



Designation	Clamping key
TID060-090	K-TID6-9.99
TID100-190	K-TID10-19.99
TID200-250	K-TID20-26.99

TID-F L/D=3

Exchangeable head drill

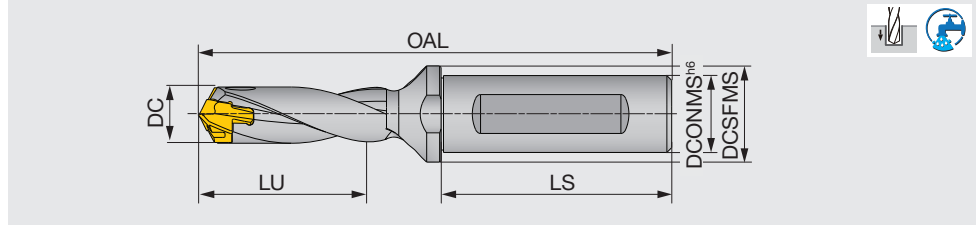

Designation	DC	DCONMS	DCSFMS	LU	LS	OAL			Pocket size	Head
						DMP/H/N	DMC	DMF		
TID060F12-3	6 - 6.4	12	16	19	45	76.9	77	76	6	DM*060 - DM*064
TID065F12-3	6.5 - 6.9	12	16	21	45	78.7	78.8	77.8	6.5	DM*065 - DM*069
TID070F12-3	7 - 7.4	12	16	22	45	80.5	80.9	79.6	7	DM*070 - DM*074
TID075F12-3	7.5 - 7.9	12	16	24	45	82	82.4	81.1	7	DM*075 - DM*079
TID080F12-3	8 - 8.4	12	16	26	45	84.3	84.4	83.4	8	DM*080 - DM*084
TID085F12-3	8.5 - 8.9	12	16	28	45	85.8	85.9	84.9	8	DM*085 - DM*089
TID090F12-3	9 - 9.4	12	16	29	45	87.7	87.8	86.6	9	DM*090 - DM*094
TID095F12-3	9.5 - 9.9	12	16	31	45	89.2	89.3	88.1	9	DM*095 - DM*099
TID100F16-3	10 - 10.4	16	20	32	48	94.1	94.7	92.7	10	DM*100 - DM*104
TID105F16-3	10.5 - 10.9	16	20	34	48	95.6	96.2	94.2	10	DM*105 - DM*109
TID110F16-3	11 - 11.4	16	20	35	48	97.5	98.1	95.9	11	DM*110 - DM*114
TID115F16-3	11.5 - 11.9	16	20	37	48	99	99.6	97.4	11	DM*115 - DM*119
TID120F16-3	12 - 12.4	16	20	38	48	100.8	101.4	99.2	12	DM*120 - DM*124
TID125F16-3	12.5 - 12.9	16	20	39	48	102.3	102.9	100.7	12	DM*125 - DM*129
TID130F16-3	13 - 13.4	16	20	41	48	104.4	105.2	102.5	13	DM*130 - DM*134
TID135F16-3	13.5 - 13.9	16	20	44	48	105.9	106.7	104	13	DM*135 - DM*139
TID140F16-3	14 - 14.4	16	20	45	48	110	110.8	108	14	DM*140 - DM*144
TID145F16-3	14.5 - 14.9	16	20	47	48	111.5	112.3	109.5	14	DM*145 - DM*149
TID150F20-3	15 - 15.9	20	25	48	50	118.5	119.4	116.4	15	DM*150 - DM*159
TID160F20-3	16 - 16.9	20	25	51	50	123.1	124.1	120.8	16	DM*160 - DM*169
TID170F20-3	17 - 17.9	20	25	54	50	127.7	128.7	125.2	17	DM*170 - DM*179
TID180F25-3	18 - 18.9	25	32	57	56	138.3	139.4	135.5	18	DM*180 - DM*189
TID190F25-3	19 - 19.9	25	32	61	56	142.8	143.9	139.8	19	DM*190 - DM*199
TID200F25-3	20 - 20.9	25	32	64	56	147.4	148.6	145.1	20	DM*200 - DM*209
TID210F25-3	21 - 21.9	25	32	67	56	152	153.2	149.5	21	DM*210 - DM*219
TID220F25-3	22 - 22.9	25	32	70	56	156.6	157.8	153.9	22	DM*220 - DM*229
TID230F32-3	23 - 23.9	32	42	73	60	165.1	166.5	162.3	23	DM*230 - DM*239
TID240F32-3	24 - 24.9	32	42	76	60	169.7	171.1	166.7	24	DM*240 - DM*249
TID250F32-3	25 - 25.9	32	42	80	60	174.3	175.8	171.2	25	DM*250 - DM*259

Tool diameter	Hole diameter tolerance*
ø6 - ø25.9	IT8 - 9

- An overall length (OAL) differs based on each head geometry.
 - For drill diameters from ø8 mm - ø9.9 mm, the drill shoulder to shank bottom distance when a DMC drill head is mounted is 0.3 mm shorter when compared with a DMP head of the equivalent sizes. The distances are the same for the DMC and DMP drill heads in other diameters than the above.

*Just for reference

SPARE PARTS



Designation	Clamping key
TID060-095	K-TID6-9.99
TID100-190	K-TID10-19.99
TID200-250	K-TID20-26.99

TID-F L/D=5

Exchangeable head drill

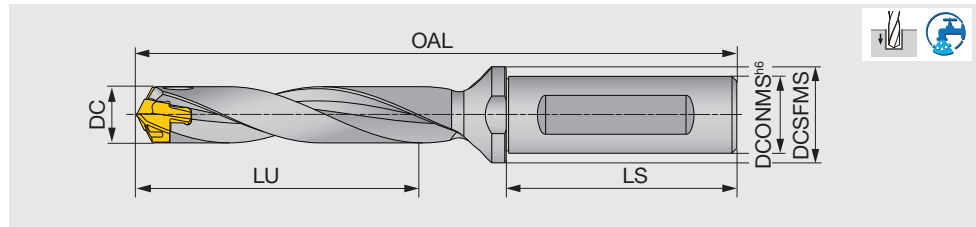

Designation	DC	DCONMS	DCSFMS	LU	LS	OAL			Pocket size	Head
						DMP/H/N	DMC	DMF		
TID060F12-5	6 - 6.4	12	16	31	45	88.9	89	88	6	DM*060 - DM*064
TID065F12-5	6.5 - 6.9	12	16	34	45	91.7	91.8	90.8	6.5	DM*065 - DM*069
TID070F12-5	7 - 7.4	12	16	36	45	94.5	94.9	93.6	7	DM*070 - DM*074
TID075F12-5	7.5 - 7.9	12	16	39	45	97	97.4	96.1	7	DM*075 - DM*079
TID080F12-5	8 - 8.4	12	16	42	45	100.3	100.4	99.4	8	DM*080 - DM*084
TID085F12-5	8.5 - 8.9	12	16	45	45	102.8	102.9	101.9	8	DM*085 - DM*089
TID090F12-5	9 - 9.4	12	16	47	45	105.7	105.8	104.6	9	DM*090 - DM*094
TID095F12-5	9.5 - 9.9	12	16	50	45	108.2	108.3	107.1	9	DM*095 - DM*099
TID100F16-5	10 - 10.4	16	20	52	48	114.1	114.7	112.7	10	DM*100 - DM*104
TID105F16-5	10.5 - 10.9	16	20	55	48	116.6	117.2	115.2	10	DM*105 - DM*109
TID110F16-5	11 - 11.4	16	20	57	48	119.5	120.1	117.9	11	DM*110 - DM*114
TID115F16-5	11.5 - 11.9	16	20	60	48	122	122.6	120.4	11	DM*115 - DM*119
TID120F16-5	12 - 12.4	16	20	62	48	124.8	125.4	123.2	12	DM*120 - DM*124
TID125F16-5	12.5 - 12.9	16	20	64	48	127.3	127.9	125.7	12	DM*125 - DM*129
TID130F16-5	13 - 13.4	16	20	67	48	130.4	131.2	128.5	13	DM*130 - DM*134
TID135F16-5	13.5 - 13.9	16	20	71	48	132.9	133.7	131	13	DM*135 - DM*139
TID140F16-5	14 - 14.4	16	20	73	48	138	138.8	136	14	DM*140 - DM*144
TID145F16-5	14.5 - 14.9	16	20	76	48	140.5	141.3	138.5	14	DM*145 - DM*149
TID150F20-5	15 - 15.9	20	25	78	50	148.5	149.4	146.4	15	DM*150 - DM*159
TID160F20-5	16 - 16.9	20	25	83	50	155.1	156.1	152.8	16	DM*160 - DM*169
TID170F20-5	17 - 17.9	20	25	88	50	161.7	162.7	159.2	17	DM*170 - DM*179
TID180F25-5	18 - 18.9	25	32	93	56	174.3	175.4	171.5	18	DM*180 - DM*189
TID190F25-5	19 - 19.9	25	32	99	56	180.8	181.9	177.8	19	DM*190 - DM*199
TID200F25-5	20 - 20.9	25	32	104	56	187.6	188.8	185.3	20	DM*200 - DM*209
TID210F25-5	21 - 21.9	25	32	109	56	194.2	195.4	191.8	21	DM*210 - DM*219
TID220F25-5	22 - 22.9	25	32	114	56	200.8	202.1	198.1	22	DM*220 - DM*229
TID230F32-5	23 - 23.9	32	42	119	60	211.3	212.7	208.5	23	DM*230 - DM*239
TID240F32-5	24 - 24.9	32	42	124	60	217.9	219.3	214.9	24	DM*240 - DM*249
TID250F32-5	25 - 25.9	32	42	130	60	224.5	226	221.4	25	DM*250 - DM*259

Tool diameter	Hole diameter tolerance*
ø6 - ø25.9	IT8 - 10

- An overall length (OAL) differs based on each head geometry.
 - For drill diameters from ø8 mm - ø9.9 mm, the drill shoulder to shank bottom distance when a DMC drill head is mounted is 0.3 mm shorter when compared with a DMP head of the equivalent sizes. The distances are the same for the DMC and DMP drill heads in other diameters than the above.

*Just for reference

SPARE PARTS



Designation	Clamping key
TID060-095	K-TID6-9.99
TID100-190	K-TID10-19.99
TID200-250	K-TID20-26.99

TID-F L/D=8

Exchangeable head drill

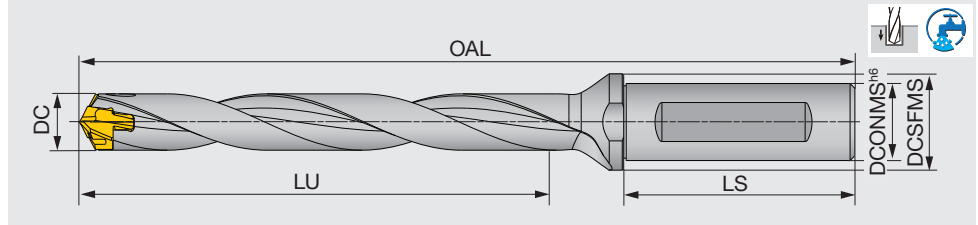

Designation	DC	DCONMS	DCSFMS	LU	LS	OAL			Pocket size	Head
						DMP/H/N	DMC	DMF		
TID070F12-8	7 - 7.4	12	16	57	45	115.5	115.9	114.6	7	DM*070 - DM*074
TID075F12-8	7.5 - 7.9	12	16	61	45	119.5	119.9	118.6	7	DM*075 - DM*079
TID080F12-8	8 - 8.4	12	16	66	45	124.3	124.4	123.4	8	DM*080 - DM*084
TID085F12-8	8.5 - 8.9	12	16	70	45	128.3	128.4	127.4	8	DM*085 - DM*089
TID090F12-8	9 - 9.4	12	16	74	45	132.7	132.8	131.6	9	DM*090 - DM*094
TID095F12-8	9.5 - 9.9	12	16	78	45	136.7	136.8	135.6	9	DM*095 - DM*099
TID100F16-8	10 - 10.4	16	20	82	48	144.1	144.7	142.7	10	DM*100 - DM*104
TID105F16-8	10.5 - 10.9	16	20	86	48	148.1	148.7	146.7	10	DM*105 - DM*109
TID110F16-8	11 - 11.4	16	20	90	48	152.5	153.1	150.9	11	DM*110 - DM*114
TID115F16-8	11.5 - 11.9	16	20	94	48	156.5	157.1	154.9	11	DM*115 - DM*119
TID120F16-8	12 - 12.4	16	20	98	48	160.8	161.4	159.2	12	DM*120 - DM*124
TID125F16-8	12.5 - 12.9	16	20	102	48	164.8	165.4	163.2	12	DM*125 - DM*129
TID130F16-8	13 - 13.4	16	20	106	48	169.4	170.2	167.5	13	DM*130 - DM*134
TID135F16-8	13.5 - 13.9	16	20	111	48	173.4	174.2	171.5	13	DM*135 - DM*139
TID140F16-8	14 - 14.4	16	20	115	48	180	180.8	178	14	DM*140 - DM*144
TID145F16-8	14.5 - 14.9	16	20	119	48	184	184.8	182	14	DM*145 - DM*149
TID150F20-8	15 - 15.9	20	25	123	50	193.5	194.4	191.4	15	DM*150 - DM*159
TID160F20-8	16 - 16.9	20	25	131	50	203.1	204.1	200.8	16	DM*160 - DM*169
TID170F20-8	17 - 17.9	20	25	139	50	212.7	213.7	210.2	17	DM*170 - DM*179
TID180F25-8	18 - 18.9	25	32	147	56	228.3	229.4	225.5	18	DM*180 - DM*189
TID190F25-8	19 - 19.9	25	32	156	56	237.8	238.9	234.8	19	DM*190 - DM*199
TID200F25-8	20 - 20.9	25	32	164	56	247.4	248.6	245.1	20	DM*200 - DM*209
TID210F25-8	21 - 21.9	25	32	172	56	257	258.2	254.5	21	DM*210 - DM*219
TID220F25-8	22 - 22.9	25	32	180	56	266.6	267.8	263.9	22	DM*220 - DM*229
TID230F32-8	23 - 23.9	32	42	188	60	280.1	281.5	277.3	23	DM*230 - DM*239
TID240F32-8	24 - 24.9	32	42	196	60	289.7	291.1	286.7	24	DM*240 - DM*249
TID250F32-8	25 - 25.9	32	42	205	60	299.3	300.8	296.2	25	DM*250 - DM*259

Tool diameter	Hole diameter tolerance*
ø7 - ø25.9	IT8 - 10

- An overall length (OAL) differs based on each head geometry.
 - For drill diameters from ø8 mm - ø9.9 mm, the drill shoulder to shank bottom distance when a DMC drill head is mounted is 0.3 mm shorter when compared with a DMP head of the equivalent sizes. The distances are the same for the DMC and DMP drill heads in other diameters than the above.

*Just for reference

SPARE PARTS



Designation	Clamping key
TID070-095	K-TID6-9.99
TID100-190	K-TID10-19.99
TID200-250	K-TID20-26.99

New

TID-R-2E

Exchangeable head drill (For external coolant supply)

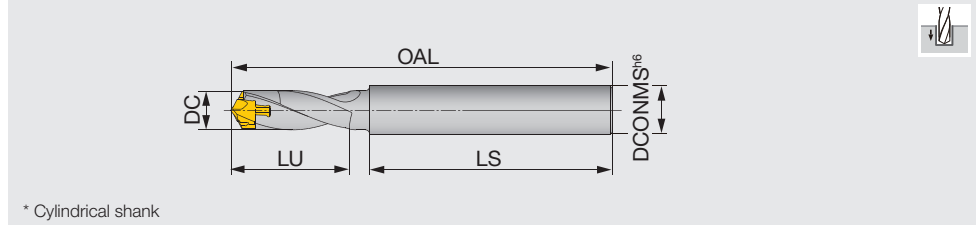

* Cylindrical shank

Designation	DC	DCONMS	LU	LS	OAL			Pocket size	Head
					DMP/H/N	DMC	DMF		
TID060R8-2E	6 - 6.4	8	12	45	66.1	66.2	65.2	6	DM*060 - DM*064
TID065R8-2E	6.5 - 6.9	8	13	45	67.2	67.3	66.3	6.5	DM*065 - DM*069
TID070R8-2E	7 - 7.4	8	13	45	68	68.4	67.1	7	DM*070 - DM*074
TID075R8-2E	7.5 - 7.9	8	14	45	69	69.4	68.1	7	DM*075 - DM*079
TID080R10-2E	8 - 8.9	10	15	50	75.2	75.3	74.3	8	DM*080 - DM*089
TID090R10-2E	9 - 9.9	10	17	50	77.4	77.5	76.3	9	DM*090 - DM*099
TID100R12-2E	10 - 10.9	12	22	60	94.3	94.9	92.9	10	DM*100 - DM*109
TID110R12-2E	11 - 11.9	12	24	60	96.5	97.1	94.9	11	DM*110 - DM*119
TID120R14-2E	12 - 12.9	14	26	65	103.6	104.2	102	12	DM*120 - DM*129
TID130R14-2E	13 - 13.9	14	27	65	108.8	109.6	106.9	13	DM*130 - DM*139
TID140R16-2E	14 - 14.9	16	29	70	115	115.8	113	14	DM*140 - DM*149
TID150R16-2E	15 - 15.9	16	32	70	118	118.9	115.9	15	DM*150 - DM*159
TID160R18-2E	16 - 16.9	16	33	70	122.2	123.2	119.9	16	DM*160 - DM*169

Tool diameter	Hole diameter tolerance*
ø6 - ø16.9	IT8 - 10

*Just for reference

- An overall length (OAL) differs based on each head geometry.
- When using the drill at a higher feed rate, make sure to provide an axial support by placing the overhang adjusting screw at the drill shank end in the tool holder. This will prevent high thrust force from pushing the drill back into the holder during drilling.
- When axially adjusting the shank inside the holder to obtain a required drill overhang, make sure the shank length remaining inside the holder does not come short of the minimum clamping length (LSCN) specified by the holder supplier.
- For drill diameters from ø8 mm - ø9.9 mm, the drill shoulder to shank bottom distance when a DMC drill head is mounted is 0.3 mm shorter when compared with a DMP head of the equivalent sizes. The distances are the same for the DMC and DMP drill heads in other diameters than the above.

SPARE PARTS

Designation	Clamping key
TID060-095	K-TID6-9.99
TID100-160	K-TID10-19.99



TID-R L/D=3.5

Exchangeable head drill

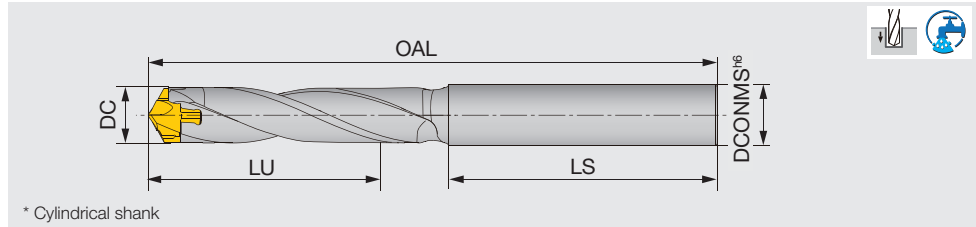

Designation	DC	DCONMS	LU	LS	OAL			Pocket size	Head
					DMP/H/N	DMC	DMF		
TID060R8-3.5	6 - 6.4	8	21	45	75.6	75.8	74.8	6	DM*060 - DM*064
TID065R8-3.5	6.5 - 6.9	8	23	45	77.5	77.6	76.6	6.5	DM*065 - DM*069
TID070R8-3.5	7 - 7.4	8	25	45	79.1	79.5	78.2	7	DM*070 - DM*074
TID075R8-3.5	7.5 - 7.9	8	26	45	80.8	81.3	80	7	DM*075 - DM*079
TID080R10-3.5	8 - 8.4	10	28	50	87.8	87.9	86.9	8	DM*080 - DM*084
TID085R10-3.5	8.5 - 8.9	10	30	50	89.5	89.7	88.6	8	DM*085 - DM*089
TID090R10-3.5	9 - 9.4	10	32	50	91.4	91.6	90.4	9	DM*090 - DM*094
TID095R10-3.5	9.5 - 9.9	10	33	50	93.2	93.3	92.1	9	DM*095 - DM*099
TID100R12-3.5	10 - 10.4	12	42	60	114	114.7	112.7	10	DM*100 - DM*104
TID105R12-3.5	10.5 - 10.9	12	44	60	115.7	116.3	114.4	10	DM*105 - DM*109
TID110R12-3.5	11 - 11.4	12	46	65	123.1	123.8	121.6	11	DM*110 - DM*114
TID115R12-3.5	11.5 - 11.9	12	48	65	124.8	125.4	123.2	11	DM*115 - DM*119
TID120R14-3.5	12 - 12.4	14	50	65	127.2	127.8	125.6	12	DM*120 - DM*124
TID125R14-3.5	12.5 - 12.9	14	52	65	128.8	129.5	127.3	12	DM*125 - DM*129
TID130R14-3.5	13 - 13.4	14	54	65	132.7	133.5	130.9	13	DM*130 - DM*134
TID135R14-3.5	13.5 - 13.9	14	56	65	134.4	135.2	132.5	13	DM*135 - DM*139
TID140R16-3.5	14 - 14.4	16	58	70	142.2	143	140.2	14	DM*140 - DM*144
TID145R16-3.5	14.5 - 14.9	16	60	70	143.8	144.7	141.9	14	DM*145 - DM*149
TID150R16-3.5	15 - 15.9	16	64	70	148.4	149.4	146.3	15	DM*150 - DM*159
TID160R18-3.5	16 - 16.9	18	68	70	153.9	154.9	151.7	16	DM*160 - DM*169
TID170R18-3.5	17 - 17.9	18	72	70	158.5	159.4	155.9	17	DM*170 - DM*179
TID180R20-3.5	18 - 18.9	20	76	70	164	165.1	161.2	18	DM*180 - DM*189
TID190R20-3.5	19 - 19.9	20	80	70	168.4	169.5	165.4	19	DM*190 - DM*199

Tool diameter	Hole diameter tolerance*
ø6 - ø19.9	IT8 - 10

*Just for reference

- An overall length (OAL) differs based on each head geometry.
- When using the drill at a higher feed rate, make sure to provide an axial support by placing the overhang adjusting screw at the drill shank end in the tool holder. This will prevent high thrust force from pushing the drill back into the holder during drilling.
- When axially adjusting the shank inside the holder to obtain a required drill overhang, make sure the shank length remaining inside the holder does not come short of the minimum clamping length (LSCN) specified by the holder supplier.
- For drill diameters from ø8 mm - ø9.9 mm, the drill shoulder to shank bottom distance when a DMC drill head is mounted is 0.3 mm shorter when compared with a DMP head of the equivalent sizes. The distances are the same for the DMC and DMP drill heads in other diameters than the above.



SPARE PARTS

Designation	Clamping key
TID060-095	K-TID6-9.99
TID100-190	K-TID10-19.99

TID-R L/D=6

Exchangeable head drill

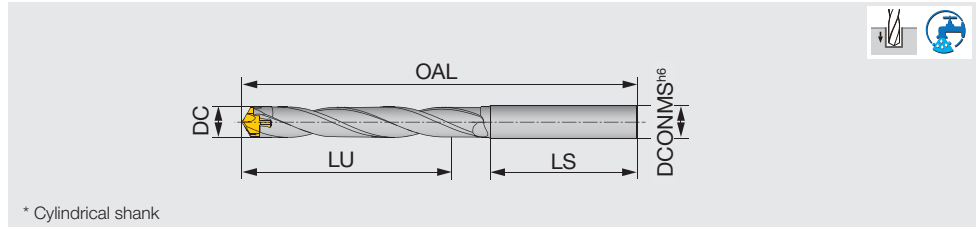

Designation	DC	DCONMS	LU	LS	OAL			Pocket size	Head
					DMP/H/N	DMC	DMF		
TID060R8-6	6 - 6.4	8	36	45	91.6	91.8	90.8	6	DM*060 - DM*064
TID065R8-6	6.5 - 6.9	8	39	45	94.7	94.9	93.9	6.5	DM*065 - DM*069
TID070R8-6	7 - 7.4	8	42	45	97.6	98	96.7	7	DM*070 - DM*074
TID075R8-6	7.5 - 7.9	8	45	45	100.6	101	99.7	7	DM*075 - DM*079
TID080R10-6	8 - 8.4	10	48	50	108.8	108.9	107.9	8	DM*080 - DM*084
TID085R10-6	8.5 - 8.9	10	51	50	111.8	111.9	110.9	8	DM*085 - DM*089
TID090R10-6	9 - 9.4	10	54	50	114.9	115.1	113.9	9	DM*090 - DM*094
TID095R10-6	9.5 - 9.9	10	57	50	117.9	118.1	116.9	9	DM*095 - DM*099
TID100R12-6	10 - 10.4	12	68	60	140	140.7	138.7	10	DM*100 - DM*104
TID105R12-6	10.5 - 10.9	12	71	60	142.9	143.6	141.6	10	DM*105 - DM*109
TID110R12-6	11 - 11.4	12	75	65	151.6	152.3	150.1	11	DM*110 - DM*114
TID115R12-6	11.5 - 11.9	12	78	65	154.5	155.2	153	11	DM*115 - DM*119
TID120R14-6	12 - 12.4	14	81	65	158.2	158.8	156.6	12	DM*120 - DM*124
TID125R14-6	12.5 - 12.9	14	84	65	161.1	161.7	159.5	12	DM*125 - DM*129
TID130R14-6	13 - 13.4	14	88	65	166.2	167	164.4	13	DM*130 - DM*134
TID135R14-6	13.5 - 13.9	14	91	65	169.2	169.9	167.3	13	DM*135 - DM*139
TID140R16-6	14 - 14.4	16	94	70	178.2	179	176.2	14	DM*140 - DM*144
TID145R16-6	14.5 - 14.9	16	97	70	181.1	181.9	179.1	14	DM*145 - DM*149
TID150R16-6	15 - 15.9	16	104	70	188.2	189.1	186.1	15	DM*150 - DM*159
TID160R18-6	16 - 16.9	18	110	70	196.2	197.2	193.9	16	DM*160 - DM*169
TID170R18-6	17 - 17.9	18	117	70	203.2	204.2	200.7	17	DM*170 - DM*179
TID180R20-6	18 - 18.9	20	124	70	211.3	212.3	208.4	18	DM*180 - DM*189
TID190R20-6	19 - 19.9	20	130	70	218.1	219.2	215.1	19	DM*190 - DM*199

Tool diameter	Hole diameter tolerance*
ø6 - ø19.9	IT8 - 10

*Just for reference

- An overall length (OAL) differs based on each head geometry.
- When using the drill at a higher feed rate, make sure to provide an axial support by placing the overhang adjusting screw at the drill shank end in the tool holder. This will prevent high thrust force from pushing the drill back into the holder during drilling.
- When axially adjusting the shank inside the holder to obtain a required drill overhang, make sure the shank length remaining inside the holder does not come short of the minimum clamping length (LSCN) specified by the holder supplier.
- For drill diameters from ø8 mm - ø9.9 mm, the drill shoulder to shank bottom distance when a DMC drill head is mounted is 0.3 mm shorter when compared with a DMP head of the equivalent sizes. The distances are the same for the DMC and DMP drill heads in other diameters than the above.

SPARE PARTS

Designation	Clamping key
TID060-095	K-TID6-9.99
TID100-190	K-TID10-19.99

TID-R L/D=8

Exchangeable head drill

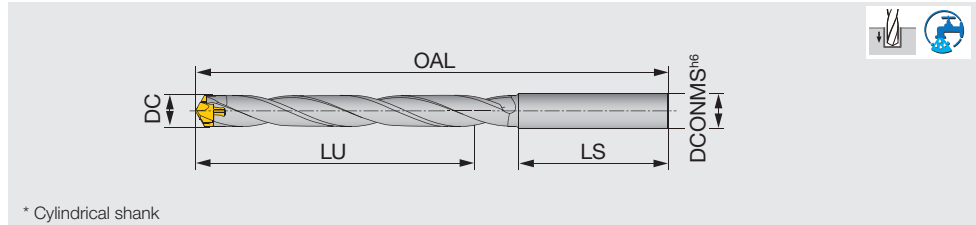

Designation	DC	DCONMS	LU	LS	OAL			Pocket size	Head
					DMP/H/N	DMC	DMF		
TID060R8-8	6 - 6.4	8	48	45	104.4	104.6	103.6	6	DM*060 - DM*064
TID065R8-8	6.5 - 6.9	8	52	45	108.5	108.7	107.7	6.5	DM*065 - DM*069
TID070R8-8	7 - 7.4	8	56	45	112.4	112.8	111.5	7	DM*070 - DM*074
TID075R8-8	7.5 - 7.9	8	60	45	116.4	116.8	115.5	7	DM*075 - DM*079
TID080R10-8	8 - 8.4	10	64	50	125.6	125.7	124.7	8	DM*080 - DM*084
TID085R10-8	8.5 - 8.9	10	68	50	129.6	129.7	128.7	8	DM*085 - DM*089
TID090R10-8	9 - 9.4	10	72	50	133.7	133.9	132.7	9	DM*090 - DM*094
TID095R10-8	9.5 - 9.9	10	76	50	137.7	137.9	136.7	9	DM*095 - DM*099
TID100R12-8	10 - 10.4	12	89	60	160.8	161.5	159.5	10	DM*100 - DM*104
TID105R12-8	10.5 - 10.9	12	93	60	164.7	165.4	163.4	10	DM*105 - DM*109
TID110R12-8	11 - 11.4	12	98	65	174.4	175.1	172.9	11	DM*110 - DM*114
TID115R12-8	11.5 - 11.9	12	102	65	178.3	179	176.8	11	DM*115 - DM*119
TID120R14-8	12 - 12.4	14	106	65	183	183.6	181.4	12	DM*120 - DM*124
TID125R14-8	12.5 - 12.9	14	110	65	186.9	187.5	185.3	12	DM*125 - DM*129
TID130R14-8	13 - 13.4	14	115	65	193	193.8	191.2	13	DM*130 - DM*134
TID135R14-8	13.5 - 13.9	14	119	65	196.9	197.7	195	13	DM*135 - DM*139
TID140R16-8	14 - 14.4	16	123	70	207	207.8	205	14	DM*140 - DM*144
TID145R16-8	14.5 - 14.9	16	127	70	210.9	211.7	208.9	14	DM*145 - DM*149
TID150R16-8	15 - 15.9	16	136	70	220	220.9	217.9	15	DM*150 - DM*159
TID160R18-8	16 - 16.9	18	144	70	230	231	227.7	16	DM*160 - DM*169
TID170R18-8	17 - 17.9	18	153	70	239	240	236.5	17	DM*170 - DM*179
TID180R20-8	18 - 18.9	20	162	70	249.1	250.1	246.2	18	DM*180 - DM*189
TID190R20-8	19 - 19.9	20	170	70	257.9	259	254.9	19	DM*190 - DM*199

Tool diameter	Hole diameter tolerance*
ø6 - ø19.9	IT8 - 10

*Just for reference

- An overall length (OAL) differs based on each head geometry.
- When using the drill at a higher feed rate, make sure to provide an axial support by placing the overhang adjusting screw at the drill shank end in the tool holder. This will prevent high thrust force from pushing the drill back into the holder during drilling.
- When axially adjusting the shank inside the holder to obtain a required drill overhang, make sure the shank length remaining inside the holder does not come short of the minimum clamping length (LSCN) specified by the holder supplier.
- For drill diameters from ø8 mm - ø9.9 mm, the drill shoulder to shank bottom distance when a DMC drill head is mounted is 0.3 mm shorter when compared with a DMP head of the equivalent sizes. The distances are the same for the DMC and DMP drill heads in other diameters than the above.

SPARE PARTS

Designation	Clamping key
TID060-095	K-TID6-9.99
TID100-190	K-TID10-19.99

TID-R L/D=12

Exchangeable head drill

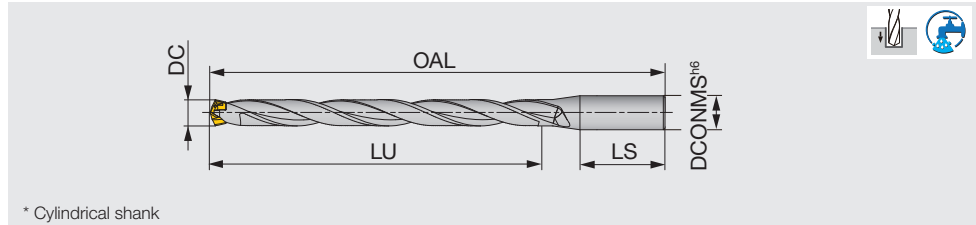

Designation	DC	DCONMS	LU	LS	OAL			Pocket size	Head
					DMP/H/N	DMC	DMF		
TID080R12-12	8 - 8.4	12	98	45	156.3	156.4	155.4	8	DM*080 - DM*084
TID085R12-12	8.5 - 8.9	12	104	45	162.3	162.4	161.4	8	DM*085 - DM*089
TID090R12-12	9 - 9.4	12	110	45	168.7	168.8	167.6	9	DM*090 - DM*094
TID095R12-12	9.5 - 9.9	12	116	45	174.7	174.8	173.6	9	DM*095 - DM*099
TID100R16-12	10 - 10.4	16	122	48	184.1	184.7	182.7	10	DM*100 - DM*104
TID105R16-12	10.5 - 10.9	16	128	48	190.1	190.7	188.7	10	DM*105 - DM*109
TID110R16-12	11 - 11.4	16	134	48	196.5	197.1	194.9	11	DM*110 - DM*114
TID115R16-12	11.5 - 11.9	16	140	48	202.5	203.1	200.9	11	DM*115 - DM*119
TID120R16-12	12 - 12.4	16	146	48	208.8	209.4	207.2	12	DM*120 - DM*124
TID125R16-12	12.5 - 12.9	16	152	48	214.8	215.4	213.2	12	DM*125 - DM*129
TID130R16-12	13 - 13.4	16	158	48	221.4	222.2	219.5	13	DM*130 - DM*134
TID135R16-12	13.5 - 13.9	16	165	48	227.4	228.2	225.5	13	DM*135 - DM*139
TID140R16-12	14 - 14.4	16	171	48	236	236.8	234	14	DM*140 - DM*144
TID145R16-12	14.5 - 14.9	16	177	48	242	242.8	240	14	DM*145 - DM*149
TID150R20-12	15 - 15.9	20	183	50	253.5	254.4	251.4	15	DM*150 - DM*159
TID160R20-12	16 - 16.9	20	195	50	267.1	268.1	264.8	16	DM*160 - DM*169
TID170R20-12	17 - 17.9	20	207	50	280.7	281.7	278.2	17	DM*170 - DM*179
TID180R25-12	18 - 18.9	25	219	56	300.3	301.4	297.5	18	DM*180 - DM*189
TID190R25-12	19 - 19.9	25	232	56	313.8	314.9	310.8	19	DM*190 - DM*199
TID200R25-12	20 - 20.9	25	244	56	327.4	328.6	325.1	20	DM*200 - DM*209
TID210R25-12	21 - 21.9	25	256	56	341	342.2	338.5	21	DM*210 - DM*219
TID220R25-12	22 - 22.9	25	267	56	354.6	355.8	351.9	22	DM*220 - DM*229
TID230R32-12	23 - 23.9	32	276	60	372.1	373.5	369.3	23	DM*230 - DM*239
TID240R32-12	24 - 24.9	32	288	60	385.7	387.1	382.7	24	DM*240 - DM*249
TID250R32-12	25 - 25.9	32	300	60	399.3	400.8	396.2	25	DM*250 - DM*259

Tool diameter	Hole diameter tolerance*
ø8 - ø25.9	IT8 - 10

*Just for reference

- An overall length (OAL) differs based on each head geometry.
- When using the drill at a higher feed rate, make sure to provide an axial support by placing the overhang adjusting screw at the drill shank end in the tool holder. This will prevent high thrust force from pushing the drill back into the holder during drilling.
- For drill diameters from ø8 mm - ø9.9 mm, the drill shoulder to shank bottom distance when a DMC drill head is mounted is 0.3 mm shorter when compared with a DMP head of the equivalent sizes. The distances are the same for the DMC and DMP drill heads in other diameters than the above.

SPARE PARTS

Designation	Clamping key
TID080-095	K-TID6-9.99
TID100-190	K-TID10-19.99
TID200-250	K-TID20-26.99

TIDC L/D=3

Exchangeable head drill

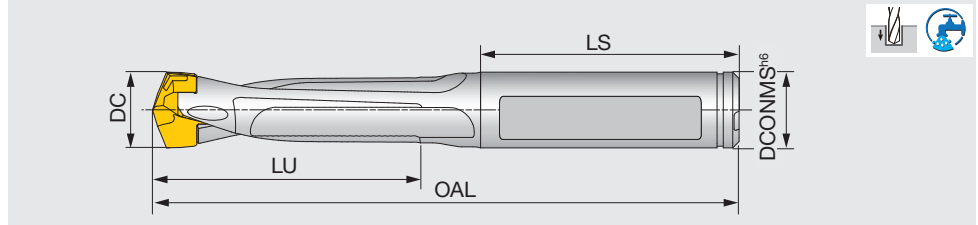

Designation	DC	DCONMS	LU	LS	OAL			Pocket size	Head
					DMP/H/N	DMC	DMF		
TIDC075C8-3	7.5 - 7.9	8	23	36	70.1	70.6	69.2	7	DM*075 - DM*079
TIDC080C8-3	8 - 8.4	8	24	36	70.6	70.8	69.7	8	DM*080 - DM*084
TIDC085C9-3	8.5 - 8.9	9	26	36	72.8	73	71.9	8	DM*085 - DM*089
TIDC090C9-3	9 - 9.4	9	27	36	74.7	74.9	73.7	9	DM*090 - DM*094
TIDC095C10-3	9.5 - 9.9	10	29	36	76.2	76.4	75.2	9	DM*095 - DM*099
TIDC100C10-3	10 - 10.4	10	32	41	86.1	86.7	84.8	10	DM*100 - DM*104
TIDC105C11-3	10.5 - 10.9	11	33	41	87.6	88.2	86.3	10	DM*105 - DM*109
TIDC110C11-3	11 - 11.4	11	35	41	89.5	90.2	88	11	DM*110 - DM*114
TIDC115C12-3	11.5 - 11.9	12	37	41	91	91.7	89.5	11	DM*115 - DM*119
TIDC120C12-3	12 - 12.4	12	38	41	92.8	93.4	91.2	12	DM*120 - DM*124
TIDC125C13-3	12.5 - 12.9	13	40	46	98.3	98.9	96.7	12	DM*125 - DM*129
TIDC130C13-3	13 - 13.4	13	41	47	102.4	103.2	100.5	13	DM*130 - DM*134
TIDC135C14-3	13.5 - 13.9	14	43	43	99.9	100.7	98	13	DM*135 - DM*139
TIDC140C14-3	14 - 14.4	14	45	44	103	103.8	101	14	DM*140 - DM*144
TIDC145C15-3	14.5 - 14.9	15	46	45	105.5	106.3	103.5	14	DM*145 - DM*149
TIDC150C15-3	15 - 15.9	15	48	45	107.5	108.4	105.4	15	DM*150 - DM*159
TIDC160C16-3	16 - 16.9	16	51	48	117.5	118.5	115.2	16	DM*160 - DM*169
TIDC170C17-3	17 - 17.9	17	54	48	119.7	120.7	117.2	17	DM*170 - DM*179
TIDC180C18-3	18 - 18.9	18	57	48	123.3	124.4	120.5	18	DM*180 - DM*189
TIDC190C19-3	19 - 19.9	19	61	54	132.4	133.5	129.4	19	DM*190 - DM*199

Tool diameter	Hole diameter tolerance*
ø7.5 - ø19.9	IT8 - 10

*Just for reference

- An overall length (OAL) differs based on each head geometry.
- When using the drill at a higher feed rate, make sure to provide an axial support by placing the overhang adjusting screw at the drill shank end in the tool holder. This will prevent high thrust force from pushing the drill back into the holder during drilling.
- For drill diameters from ø8 mm - ø9.9 mm, the drill shoulder to shank bottom distance when a DMC drill head is mounted is 0.3 mm shorter when compared with a DMP head of the equivalent sizes. The distances are the same for the DMC and DMP drill heads in other diameters than the above.
- When axially adjusting the shank inside the holder to obtain a required drill overhang, make sure the shank length remaining inside the holder does not come short of the minimum clamping length (LSCN) specified by the holder supplier.

SPARE PARTS



Designation	Clamping key
TIDC075-099	K-TID6-9.99
TIDC100-190	K-TID10-19.99

TIDC L/D=5

Exchangeable head drill

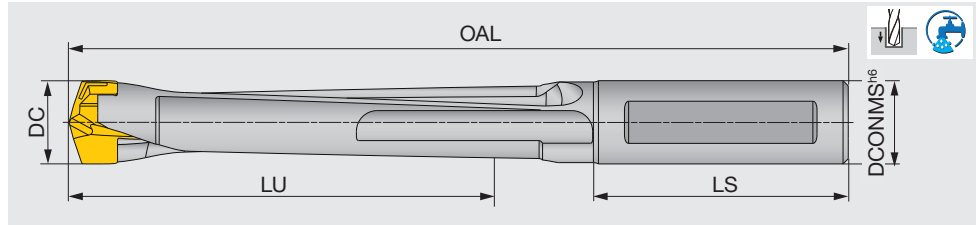

Designation	DC	DCONMS	LU	LS	OAL			Pocket size	Head
					DMP/H/N	DMC	DMF		
TIDC075C8-5	7.5 - 7.9	8	38	36	85.1	85.6	84.2	7	DM*075 - DM*079
TIDC080C8-5	8 - 8.4	8	40	36	92.3	92.5	91.4	8	DM*080 - DM*084
TIDC085C9-5	8.5 - 8.9	9	43	36	89.8	90	88.9	8	DM*085 - DM*089
TIDC090C9-5	9 - 9.4	9	45	36	92.7	92.9	91.7	9	DM*090 - DM*094
TIDC095C10-5	9.5 - 9.9	10	48	36	95.2	95.4	94.2	9	DM*095 - DM*099
TIDC100C10-5	10 - 10.4	10	52	41	106.1	106.7	104.8	10	DM*100 - DM*104
TIDC105C11-5	10.5 - 10.9	11	54	41	108.6	109.2	107.3	10	DM*105 - DM*109
TIDC110C11-5	11 - 11.4	11	57	41	111.5	112.2	110	11	DM*110 - DM*114
TIDC115C12-5	11.5 - 11.9	12	60	41	114	114.7	112.5	11	DM*115 - DM*119
TIDC120C12-5	12 - 12.4	12	62	41	116.8	117.4	115.2	12	DM*120 - DM*124
TIDC125C13-5	12.5 - 12.9	13	65	46	124.3	124.9	122.7	12	DM*125 - DM*129
TIDC130C13-5	13 - 13.4	13	67	47	128.4	129.2	126.5	13	DM*130 - DM*134
TIDC135C14-5	13.5 - 13.9	14	70	43	126.9	127.7	125	13	DM*135 - DM*139
TIDC140C14-5	14 - 14.4	14	73	44	131	131.8	129	14	DM*140 - DM*144
TIDC145C15-5	14.5 - 14.9	15	75	45	134.5	135.3	132.5	14	DM*145 - DM*149
TIDC150C15-5	15 - 15.9	15	78	45	137.5	138.4	135.4	15	DM*150 - DM*159
TIDC160C16-5	16 - 16.9	16	83	48	149.5	150.5	147.2	16	DM*160 - DM*169
TIDC170C17-5	17 - 17.9	17	88	48	153.7	154.7	151.2	17	DM*170 - DM*179
TIDC180C18-5	18 - 18.9	18	93	48	159.3	160.4	156.5	18	DM*180 - DM*189
TIDC190C19-5	19 - 19.9	19	99	54	170.4	171.5	167.4	19	DM*190 - DM*199

Tool diameter	Hole diameter tolerance*
ø7.5 - ø19.9	IT8 - 10

*Just for reference

- An overall length (OAL) differs based on each head geometry.
- When using the drill at a higher feed rate, make sure to provide an axial support by placing the overhang adjusting screw at the drill shank end in the tool holder. This will prevent high thrust force from pushing the drill back into the holder during drilling.
- For drill diameters from ø8 mm - ø9.9 mm, the drill shoulder to shank bottom distance when a DMC drill head is mounted is 0.3 mm shorter when compared with a DMP head of the equivalent sizes. The distances are the same for the DMC and DMP drill heads in other diameters than the above.
- When axially adjusting the shank inside the holder to obtain a required drill overhang, make sure the shank length remaining inside the holder does not come short of the minimum clamping length (LSCN) specified by the holder supplier.

SPARE PARTS



Designation	Clamping key
TIDC075-099	K-TID6-9.99
TIDC100-190	K-TID10-19.99

TIDCF

Chamfering adapter

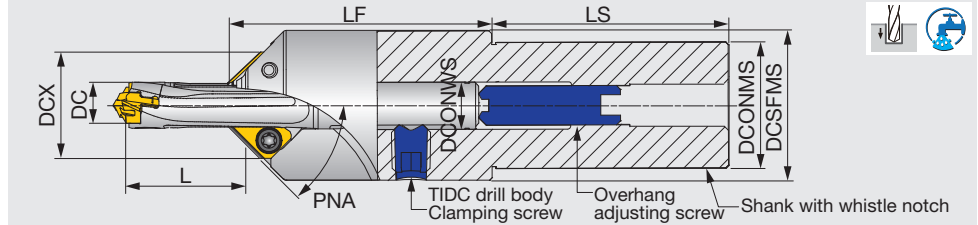

Designation	DC	DCONMS	DCSFMS	DCX	LF	LS	L* L/D = 3	L* L/D = 5	Drill body	DCONWS	Insert
TIDCF080-W20	7.5 - 7.9	20	25	18.8	47.4	50	12.6 - 24	17.3 - 38	TIDC075C8-...	8	XCGT06...
TIDCF080-W20	8.0 - 8.4	20	25	18.8	47.4	50	13.5 - 24.6	24.7 - 45	TIDC080C8-...	8	XCGT06...
TIDCF090-W20	8.5 - 8.9	20	25	19.8	47.4	50	12.6 - 26.2	18.5 - 43	TIDC085C9-...	9	XCGT06...
TIDCF090-W20	9.0 - 9.4	20	25	19.8	47.4	50	13 - 29.2	22.9 - 46.8	TIDC090C9-...	9	XCGT06...
TIDCF100-W32	9.5 - 9.9	32	38	24.9	67.3	60	12.9 - 27.8	26 - 47	TIDC095C10-...	10	XHG*09...
TIDCF100-W32	10 - 10.4	32	38	24.9	67.3	60	14.5 - 31.8	31.7 - 51.8	TIDC100C10-...	10	XHG*09...
TIDCF110-W32	10.5 - 10.9	32	38	25.9	67.3	60	15.7 - 33.3	31.2 - 54.2	TIDC105C11-...	11	XHG*09...
TIDCF110-W32	11 - 11.4	32	38	25.9	67.3	60	16.2 - 35.3	34.1 - 57.3	TIDC110C11-...	11	XHG*09...
TIDCF120-W32	11.5 - 11.9	32	38	26.9	67.3	60	15.1 - 36.7	33.8 - 59.4	TIDC115C12-...	12	XHG*09...
TIDCF120-W32	12 - 12.4	32	38	26.9	67.3	60	16.5 - 37.7	36.6 - 61.6	TIDC120C12-...	12	XHG*09...
TIDCF130-W32	12.5 - 12.9	32	38	27.9	67.3	60	16.1 - 39.6	39.7 - 64.8	TIDC125C13-...	13	XHG*09...
TIDCF130-W32	13 - 13.4	32	38	27.9	67.3	60	17.5 - 41.5	42.7 - 68	TIDC130C13-...	13	XHG*09...
TIDCF140-W32	13.5 - 13.9	32	38	28.4	67.3	60	17.7 - 42.9	41.4 - 70.3	TIDC135C14-...	14	XHG*09...
TIDCF140-W32	14 - 14.4	32	38	28.4	67.3	60	18.1 - 45	44.8 - 73.1	TIDC140C14-...	14	XHG*09...
TIDCF150-W32	14.5 - 14.9	32	38	29.4	67.3	60	19.2 - 44.6	44 - 73.9	TIDC145C15-...	15	XHG*09...
TIDCF150-W32	15 - 15.9	32	38	29.4	67.3	60	19.7 - 47.4	47.6 - 80.7	TIDC150C15-...	15	XHG*09...
TIDCF160-W32	16 - 16.9	32	38	30.4	67.3	60	19.5 - 55.3	57 - 87.5	TIDC160C16-...	16	XHG*09...
TIDCF170-W32	17 - 17.9	32	38	31.4	67.3	60	21.4 - 54.9	55.9 - 88.5	TIDC170C17-...	17	XHG*09...
TIDCF180-W32	18 - 18.9	32	38	32.4	67.3	60	24.2 - 65.2	60 - 93	TIDC180C18-...	18	XHG*09...
TIDCF190-W32	19 - 19.9	32	38	33.4	75	60	28.5 - 62.3	67 - 100	TIDC190C19-...	19	XHG*09...

L* is the dimension when using 45° chamfering insert.

SPARE PARTS

Designation	Insert screw	Grip	Clamping screw of TIDC drill body	Overhang adjusting screw	Torx bit	Wrench	Wrench
TIDCF080-090	SR14-560	-	SRM6X6DIN916	SRM6X1S	-	HW3.0	T-8D
TIDCF100-190	SR14-544/S	SW6-SD	SRM10X10DIN916	SRM10X1.5S	BT15S	HW5.0	-

Recommended clamping torque (N·m): SR14-544/S = 4.8

● How to mount the chamfering adapter on the TIDC drill body

The overhang length of the drill can be changed by the adjusting screw at the bottom of the adapter. The rear end of the drill body must be in contact with the adjusting screw as the screw supports the drill against thrust force when drilling.

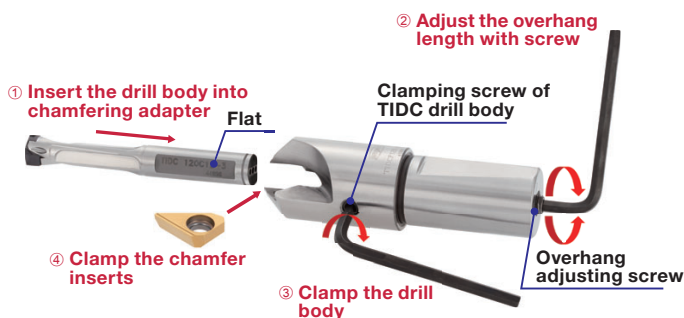

Procedures

- Place the TIDC drill body into the chamfering adapter without chamfer inserts.
- Adjust the overhang length of the drill body with the adjusting screw at the bottom of the adapter.
- Adjust the position of the drill body so that the drill body is fixed at the flat and tighten the clamping screw of the drill body. This aligns the flutes of the TIDC drill body with the chamfer inserts.
- To clamp the chamfer inserts, tighten the clamping screw of the insert while pushing the insert into the insert pocket.

Notice: Before removing the drill body from the adapter, chamfer inserts must be unclamped. The overhang adjusting screw can be handled from the top of the adapter with a flat-blade screwdriver. The overhang length of the drill body can be adjusted after the adapter is positioned on the drill shank.

CHAMFERING INSERT

XCGT-30DT/XHGT-30A

XCGT-45DT/XHGR-45A

XCGT-60DT/XHGR-60A

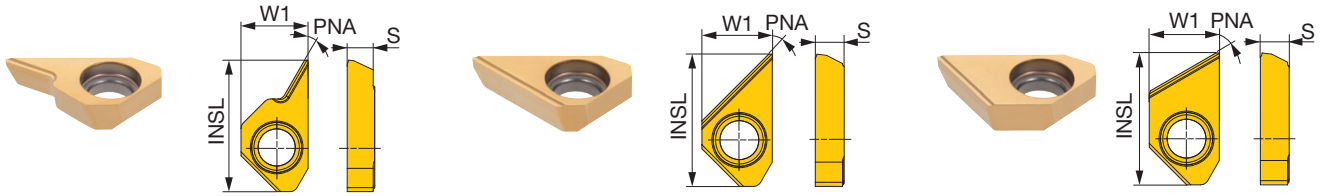

P Steel	★									
M Stainless	★									
K Cast iron	★									
N Non-ferrous	☆									
S Superalloys	★									
H Hard materials	★									

★ : First choice
☆ : Second choice

Designation	Chamfering angle PNA	Maximum width of chamfer*	Coated								W1	INSL	S
			GH730										
XCGT060300-30DT	30°	2	●								6.18	12.3	2.8
XCGT060300-45DT	45°	4	●								6.18	12.3	2.8
XCGT060300-60DT	60°	4	●								6.18	12.3	2.8
XHGT090300-30A	30°	3	●								8.5	16	3.3
XHGR090300-45A	45°	6	●								8.5	16	3.3
XHGR090300-60A	60°	6	●								8.5	16	3.3

*Please reduce the feed rate to half when chamfering over 60% of maximum width of chamfer.

● : Line up
2 pieces per package

INSERT FOR SPECIAL CHAMFERING ADAPTERS

AOMT...

AOMT06-C45

AOMT03-N-**DT

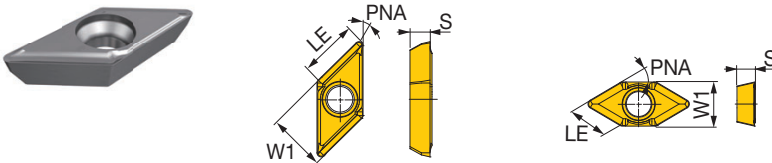

P Steel	★										
M Stainless	★										
K Cast iron	★										
N Non-ferrous	☆										
S Superalloys	★										
H Hard materials	★										

★ : First choice
☆ : Second choice

Designation	LE	Chamfering angle PNA	Coated								W1	S
			GH730									
AOMT060204-C45	4.5	45°	●								5.66	1.96
AOMT030204-N-30DT	4	30°	●								4	1.59
AOMT030204-N-45DT	4	45°	●								2.8	1.59

● : Line up

DRILL HEAD

DMP General purpose

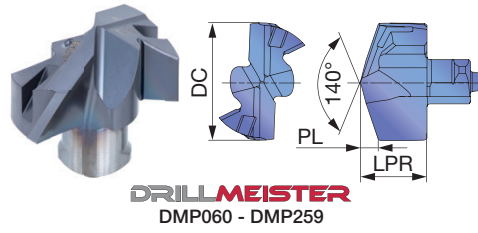

Tool diameter	Head diameter tolerance
ø4 - ø17.9	+0.018 / 0
ø18 - ø25.9	+0.021 / 0

P	Steel	★	☆
M	Stainless	★	☆
K	Cast iron	★	☆
N	Non-ferrous	☆	☆
S	Superalloys	★	☆
H	Hard materials	★	☆

P	Steel	★	☆
M	Stainless	★	☆
K	Cast iron	★	☆
N	Non-ferrous	☆	☆
S	Superalloys	★	☆
H	Hard materials	★	☆

★ : First choice
☆ : Second choice

	Designation	DC	LPR	Coated		PL	Body
				AH725	AH9130		
New	DMP040	4	3.1	●		0.62	TID*040...
New	DMP041	4.1	3.1	●		0.64	TID*040...
New	DMP042	4.2	3.1	●		0.66	TID*040...
New	DMP043	4.3	3.1	●		0.67	TID*040...
New	DMP044	4.4	3.1	●		0.69	TID*040...
New	DMP045	4.5	3.55	●		0.66	TID*045...
New	DMP046	4.6	3.55	●		0.68	TID*045...
New	DMP047	4.7	3.55	●		0.70	TID*045...
New	DMP048	4.8	3.55	●		0.71	TID*045...
New	DMP049	4.9	3.55	●		0.73	TID*045...
New	DMP050	5	3.7	●		0.73	TID*050...
New	DMP051	5.1	3.7	●		0.75	TID*050...
New	DMP052	5.2	3.7	●		0.77	TID*050...
New	DMP053	5.3	3.7	●		0.78	TID*050...
New	DMP054	5.4	3.7	●		0.8	TID*050...
New	DMP055	5.5	3.85	●		0.81	TID*055...
New	DMP056	5.6	3.85	●		0.83	TID*055...
New	DMP057	5.7	3.85	●		0.85	TID*055...
New	DMP058	5.8	3.85	●		0.86	TID*055...
New	DMP059	5.9	3.85	●		0.88	TID*055...
	DMP060	6	3.85	●		1.09	TID*060...
	DMP061	6.1	3.85	●		1.11	TID*060...
	DMP062	6.2	3.85	●		1.13	TID*060...
	DMP063	6.3	3.85	●		1.14	TID*060...
	DMP064	6.4	3.85	●		1.16	TID*060...
	DMP065	6.5	4.15	●		1.27	TID*065...
	DMP066	6.6	4.15	●		1.29	TID*065...
	DMP067	6.7	4.15	●		1.31	TID*065...
	DMP068	6.8	4.15	●	●	1.33	TID*065...
	DMP069	6.9	4.15	●		1.34	TID*065...
	DMP070	7	4.45	●		1.03	TID*070...
	DMP071	7.1	4.45	●		1.05	TID*070...
	DMP072	7.2	4.45	●		1.07	TID*070...
	DMP073	7.3	4.45	●		1.08	TID*070...
	DMP074	7.4	4.45	●		1.1	TID*070...
	DMP075	7.5	4.45	●	●	1.12	TID*075...
	DMP076	7.6	4.45	●		1.14	TID*075...

	Designation	DC	LPR	Coated		PL	Body
				AH725	AH9130		
	DMP077	7.7	4.45	●		1.16	TID*075...
	DMP078	7.8	4.45	●		1.18	TID*075...
	DMP079	7.9	4.45	●		1.19	TID*075...
	DMP080	8	5.25	●	●	1.2	TID*080...
	DMP081	8.1	5.25	●		1.22	TID*080...
	DMP082	8.2	5.25	●		1.24	TID*080...
	DMP083	8.3	5.25	●		1.25	TID*080...
	DMP084	8.4	5.25	●		1.27	TID*080...
	DMP085	8.5	5.25	●	●	1.29	TID*085...
	DMP086	8.6	5.25	●		1.31	TID*085...
	DMP087	8.7	5.25	●		1.33	TID*085...
	DMP088	8.8	5.25	●		1.35	TID*085...
	DMP089	8.9	5.25	●		1.36	TID*085...
	DMP090	9	5.65	●	●	1.37	TID*090...
	DMP091	9.1	5.65	●		1.39	TID*090...
	DMP092	9.2	5.65	●		1.41	TID*090...
	DMP093	9.3	5.65	●		1.42	TID*090...
	DMP094	9.4	5.65	●		1.44	TID*090...
	DMP095	9.5	5.65	●	●	1.46	TID*095...
	DMP096	9.6	5.65	●		1.48	TID*095...
	DMP097	9.7	5.65	●		1.5	TID*095...
	DMP098	9.8	5.65	●		1.52	TID*095...
	DMP099	9.9	5.65	●		1.53	TID*095...
	DMP100	10	6.05	●	●	1.47	TID*100...
	DMP101	10.1	6.05	●	○	1.49	TID*100...
	DMP102	10.2	6.05	●	○	1.51	TID*100...
	DMP103	10.3	6.05	●	●	1.52	TID*100...
	DMP104	10.4	6.05	●	●	1.54	TID*100...
	DMP105	10.5	6.05	●	●	1.56	TID*105...
	DMP106	10.6	6.05	●	●	1.58	TID*105...
	DMP107	10.7	6.05	●	○	1.6	TID*105...
	DMP108	10.8	6.05	●	●	1.62	TID*105...
	DMP109	10.9	6.05	●	○	1.63	TID*105...
	DMP110	11	6.45	●	●	1.67	TID*110...
	DMP111	11.1	6.45	●	●	1.69	TID*110...
	DMP112	11.2	6.45	●	●	1.71	TID*110...
	DMP113	11.3	6.45	●	●	1.72	TID*110...

ø4 - ø19.9 = 2 pieces per package
ø20 - ø25.9 = 1 piece per package

● : New product
○ : Will be released in March 2022
● : Line up

DMP General purpose

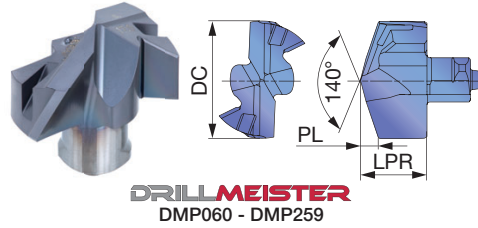

Tool diameter	Head diameter tolerance
ø4 - ø17.9	+0.018 / 0
ø18 - ø25.9	+0.021 / 0

P	Steel	★	☆
M	Stainless	★	☆
K	Cast iron	★	☆
N	Non-ferrous	☆	☆
S	Superalloys	★	☆
H	Hard materials	★	☆

P	Steel	★	☆
M	Stainless	★	☆
K	Cast iron	★	☆
N	Non-ferrous	☆	☆
S	Superalloys	★	☆
H	Hard materials	★	☆

★ : First choice
☆ : Second choice

Designation	DC	LPR	Coated		PL	Body
			AH725	AH9130		
DMP114	11.4	6.45	●	○	1.74	TID*110...
DMP115	11.5	6.45	●	●	1.76	TID*115...
DMP116	11.6	6.45	●	○	1.78	TID*115...
DMP117	11.7	6.45	●	●	1.8	TID*115...
DMP118	11.8	6.45	●	○	1.82	TID*115...
DMP119	11.9	6.45	●	○	1.83	TID*115...
DMP120	12	6.8	●	●	1.82	TID*120...
DMP121	12.1	6.8	●	●	1.84	TID*120...
DMP122	12.2	6.8	●	●	1.86	TID*120...
DMP123	12.3	6.8	●	●	1.87	TID*120...
DMP124	12.4	6.8	●	●	1.89	TID*120...
DMP125	12.5	6.8	●	●	1.91	TID*125...
DMP126	12.6	6.8	●	●	1.93	TID*125...
DMP127	12.7	6.8	●	●	1.95	TID*125...
DMP128	12.8	6.8	●	●	1.97	TID*125...
DMP129	12.9	6.8	●	○	1.98	TID*125...
DMP130	13	7.4	●	●	1.96	TID*130...
DMP131	13.1	7.4	●	○	1.98	TID*130...
DMP132	13.2	7.4	●	○	2	TID*130...
DMP133	13.3	7.4	●	●	2.01	TID*130...
DMP134	13.4	7.4	●	○	2.03	TID*130...
DMP135	13.5	7.4	●	●	2.05	TID*135...
DMP136	13.6	7.4	●	○	2.07	TID*135...
DMP137	13.7	7.4	●	●	2.09	TID*135...
DMP138	13.8	7.4	●	●	2.11	TID*135...
DMP139	13.9	7.4	●	●	2.12	TID*135...
DMP140	14	7.95	●	●	2.12	TID*140...
DMP141	14.1	7.95	●	●	2.14	TID*140...
DMP142	14.2	7.95	●	●	2.16	TID*140...
DMP143	14.3	7.95	●	●	2.17	TID*140...
DMP144	14.4	7.95	●	○	2.19	TID*140...
DMP145	14.5	7.95	●	●	2.21	TID*145...
DMP146	14.6	7.95	●	●	2.23	TID*145...
DMP147	14.7	7.95	●	○	2.25	TID*145...
DMP148	14.8	7.95	●	○	2.27	TID*145...
DMP149	14.9	7.95	●	○	2.28	TID*145...
DMP150	15	8.53	●	●	2.27	TID*150...
DMP151	15.1	8.53	●	●	2.29	TID*150...
DMP152	15.2	8.53	●	●	2.31	TID*150...

Designation	DC	LPR	Coated		PL	Body
			AH725	AH9130		
DMP153	15.3	8.53	●	○	2.32	TID*150...
DMP154	15.4	8.53	●	○	2.34	TID*150...
DMP155	15.5	8.53	●	●	2.36	TID*150...
DMP156	15.6	8.53	●	●	2.38	TID*150...
DMP157	15.7	8.53	●	●	2.4	TID*150...
DMP158	15.8	8.53	●	●	2.42	TID*150...
DMP159	15.9	8.53	●	○	2.43	TID*150...
DMP160	16	9.1	●	●	2.42	TID*160...
DMP161	16.1	9.1	●	●	2.44	TID*160...
DMP162	16.2	9.1	●	○	2.46	TID*160...
DMP163	16.3	9.1	●	●	2.47	TID*160...
DMP164	16.4	9.1	●	○	2.49	TID*160...
DMP165	16.5	9.1	●	●	2.51	TID*160...
DMP166	16.6	9.1	●	●	2.53	TID*160...
DMP167	16.7	9.1	●	●	2.55	TID*160...
DMP168	16.8	9.1	●	○	2.57	TID*160...
DMP169	16.9	9.1	●	○	2.58	TID*160...
DMP170	17	9.7	●	●	2.59	TID*170...
DMP171	17.1	9.7	●	○	2.61	TID*170...
DMP172	17.2	9.7	●	○	2.63	TID*170...
DMP173	17.3	9.7	●	○	2.64	TID*170...
DMP174	17.4	9.7	●	○	2.66	TID*170...
DMP175	17.5	9.7	●	●	2.68	TID*170...
DMP176	17.6	9.7	●	●	2.7	TID*170...
DMP177	17.7	9.7	●	○	2.72	TID*170...
DMP178	17.8	9.7	●	●	2.74	TID*170...
DMP179	17.9	9.7	●	●	2.75	TID*170...
DMP180	18	10.3	●	●	2.73	TID*180...
DMP181	18.1	10.3	●	○	2.75	TID*180...
DMP182	18.2	10.3	●	○	2.77	TID*180...
DMP183	18.3	10.3	●	●	2.78	TID*180...
DMP184	18.4	10.3	●	○	2.8	TID*180...
DMP185	18.5	10.3	●	●	2.82	TID*180...
DMP186	18.6	10.3	●	○	2.84	TID*180...
DMP187	18.7	10.3	●	○	2.86	TID*180...
DMP188	18.8	10.3	●	○	2.88	TID*180...
DMP189	18.9	10.3	●	○	2.89	TID*180...
DMP190	19	10.8	●	●	2.88	TID*190...
DMP1905	19.05	10.8	●	○	2.89	TID*190...

ø4 - ø19.9 = 2 pieces per package
ø20 - ø25.9 = 1 piece per package

○ : Will be released in March 2022
● : Line up

P	Steel	★	☆
M	Stainless	★	☆
K	Cast iron	★	☆
N	Non-ferrous	☆	☆
S	Superalloys	★	☆
H	Hard materials	★	☆

P	Steel	★	☆
M	Stainless	★	☆
K	Cast iron	★	☆
N	Non-ferrous	☆	☆
S	Superalloys	★	☆
H	Hard materials	★	☆

★ : First choice
☆ : Second choice

Designation	DC	LPR	Coated		PL	Body
			AH725	AH9130		
DMP191	19.1	10.8	●	○	2.9	TID*190...
DMP192	19.2	10.8	●	○	2.92	TID*190...
DMP1927	19.27	10.8	●	○	2.93	TID*190...
DMP193	19.3	10.8	●	●	2.93	TID*190...
DMP194	19.4	10.8	●	●	2.95	TID*190...
DMP195	19.5	10.8	●	●	2.97	TID*190...
DMP196	19.6	10.8	●	○	2.99	TID*190...
DMP197	19.7	10.8	●	○	3.01	TID*190...
DMP198	19.8	10.8	●	●	3.03	TID*190...
DMP199	19.9	10.8	●	○	3.04	TID*190...
DMP200	20	11.4	●	●	3.02	TID*200...
DMP201	20.1	11.4	●	●	3.04	TID*200...
DMP202	20.2	11.4	●	○	3.06	TID*200...
DMP203	20.3	11.4	●	○	3.07	TID*200...
DMP204	20.4	11.4	●	○	3.09	TID*200...
DMP205	20.5	11.4	●	●	3.11	TID*200...
DMP206	20.6	11.4	●	○	3.13	TID*200...
DMP207	20.7	11.4	●	○	3.15	TID*200...
DMP208	20.8	11.4	●	○	3.17	TID*200...
DMP209	20.9	11.4	●	○	3.18	TID*200...
DMP210	21	11.98	●	●	3.18	TID*210...
DMP211	21.1	11.98	●	○	3.2	TID*210...
DMP212	21.2	11.98	●	○	3.22	TID*210...
DMP213	21.3	11.98	●	○	3.23	TID*210...
DMP214	21.4	11.98	●	○	3.25	TID*210...
DMP215	21.5	11.98	●	○	3.27	TID*210...
DMP216	21.6	11.98	●	○	3.29	TID*210...
DMP217	21.7	11.98	●	○	3.31	TID*210...
DMP218	21.8	11.98	●	○	3.33	TID*210...
DMP219	21.9	11.98	●	○	3.34	TID*210...
DMP220	22	12.56	●	●	3.32	TID*220...
DMP221	22.1	12.56	●	○	3.34	TID*220...
DMP222	22.2	12.56	●	○	3.36	TID*220...
DMP223	22.3	12.56	●	●	3.37	TID*220...
DMP224	22.4	12.56	●	○	3.39	TID*220...
DMP225	22.5	12.56	●	○	3.41	TID*220...
DMP226	22.6	12.56	●	○	3.43	TID*220...
DMP227	22.7	12.56	●	○	3.45	TID*220...
DMP228	22.8	12.56	●	○	3.47	TID*220...
DMP229	22.9	12.56	●	○	3.48	TID*220...
DMP230	23	13.13	●	○	3.46	TID*230...
DMP231	23.1	13.13	●	○	3.48	TID*230...
DMP232	23.2	13.13	●	○	3.5	TID*230...
DMP233	23.3	13.13	●	○	3.51	TID*230...
DMP234	23.4	13.13	●	○	3.53	TID*230...
DMP235	23.5	13.13	●	○	3.55	TID*230...
DMP236	23.6	13.13	●	○	3.57	TID*230...
DMP237	23.7	13.13	●	○	3.59	TID*230...
DMP238	23.8	13.13	●	○	3.61	TID*230...
DMP239	23.9	13.13	●	○	3.62	TID*230...
DMP240	24	13.7	●	●	3.62	TID*240...
DMP241	24.1	13.7	●	○	3.64	TID*240...
DMP242	24.2	13.7	●	○	3.66	TID*240...
DMP243	24.3	13.7	●	○	3.67	TID*240...

Designation	DC	LPR	Coated		PL	Body
			AH725	AH9130		
DMP244	24.4	13.7	●	○	3.69	TID*240...
DMP245	24.5	13.7	●	○	3.71	TID*240...
DMP246	24.6	13.7	●	○	3.73	TID*240...
DMP247	24.7	13.7	●	○	3.75	TID*240...
DMP248	24.8	13.7	●	○	3.77	TID*240...
DMP249	24.9	13.7	●	○	3.78	TID*240...
DMP250	25	14.3	●	●	3.8	TID*250...
DMP251	25.1	14.3	●	○	3.82	TID*250...
DMP252	25.2	14.3	●	○	3.84	TID*250...
DMP253	25.3	14.3	●	○	3.85	TID*250...
DMP254	25.4	14.3	●	○	3.87	TID*250...
DMP255	25.5	14.3	●	○	3.89	TID*250...
DMP256	25.6	14.3	●	○	3.91	TID*250...
DMP2567	25.67	14.3	●	○	3.92	TID*250...
DMP257	25.7	14.3	●	○	3.93	TID*250...
DMP258	25.8	14.3	●	○	3.95	TID*250...
DMP259	25.9	14.3	●	●	3.96	TID*250...

○ : Will be released in March 2022
● : Line up

ø4 - ø19.9 = 2 pieces per package
ø20 - ø25.9 = 1 piece per package

DMC High precision machining

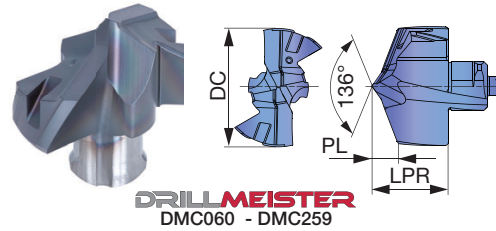
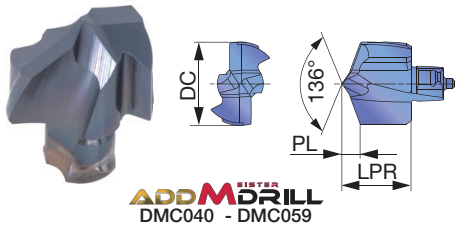

Tool diameter	Head diameter tolerance
ø4 - ø17.9	+0.018 / 0
ø18 - ø25.9	+0.021 / 0

P	Steel	★		
M	Stainless	★		
K	Cast iron	★		
N	Non-ferrous	☆		
S	Superalloys	★		
H	Hard materials	★		

P	Steel	★		
M	Stainless	★		
K	Cast iron	★		
N	Non-ferrous	☆		
S	Superalloys	★		
H	Hard materials	★		

★ : First choice
☆ : Second choice

Designation	DC	LPR	Coated		PL	Body
			AH9130			
DMC040	4	3.51	○		0.86	TID*040...
DMC041	4.1	3.51	○		0.88	TID*040...
DMC042	4.2	3.51	○		0.9	TID*040...
DMC043	4.3	3.51	○		0.92	TID*040...
DMC044	4.4	3.51	○		0.94	TID*040...
DMC045	4.5	3.81	○		0.97	TID*045...
DMC046	4.6	3.81	○		0.99	TID*045...
DMC047	4.7	3.81	○		1.01	TID*045...
DMC048	4.8	3.81	○		1.03	TID*045...
DMC049	4.9	3.81	○		1.05	TID*045...
New DMC050	5	4.14	●		1.09	TID*050...
New DMC051	5.1	4.14	●		1.11	TID*050...
New DMC052	5.2	4.14	●		1.13	TID*050...
New DMC053	5.3	4.14	●		1.15	TID*050...
New DMC054	5.4	4.14	●		1.17	TID*050...
New DMC055	5.5	4.17	●		1.22	TID*055...
New DMC056	5.6	4.17	●		1.24	TID*055...
New DMC057	5.7	4.17	●		1.26	TID*055...
New DMC058	5.8	4.17	●		1.28	TID*055...
New DMC059	5.9	4.17	●		1.3	TID*055...
DMC060	6	4	●		1.24	TID*060...
DMC061	6.1	4	●		1.26	TID*060...
DMC062	6.2	4	●		1.28	TID*060...
DMC063	6.3	4	●		1.3	TID*060...
DMC064	6.4	4	●		1.32	TID*060...
DMC065	6.5	4.3	●		1.33	TID*065...
DMC066	6.6	4.3	●		1.35	TID*065...
DMC067	6.7	4.3	●		1.37	TID*065...
DMC068	6.8	4.3	●		1.39	TID*065...
DMC069	6.9	4.3	●		1.41	TID*065...
DMC070	7	4.9	●		1.48	TID*070...
DMC071	7.1	4.9	●		1.5	TID*070...
DMC072	7.2	4.9	●		1.52	TID*070...
DMC073	7.3	4.9	●		1.54	TID*070...
DMC074	7.4	4.9	●		1.56	TID*070...
DMC075	7.5	4.9	●		1.58	TID*075...
DMC076	7.6	4.9	●		1.6	TID*075...
DMC077	7.7	4.9	●		1.62	TID*075...

Designation	DC	LPR	Coated		PL	Body
			AH9130			
DMC078	7.8	4.9	●		1.64	TID*075...
DMC079	7.9	4.9	●		1.66	TID*075...
DMC080	8	5.4	●		1.62	TID*080...
DMC081	8.1	5.4	●		1.64	TID*080...
DMC082	8.2	5.4	●		1.66	TID*080...
DMC083	8.3	5.4	●		1.68	TID*080...
DMC084	8.4	5.4	●		1.7	TID*080...
DMC085	8.5	5.4	●		1.72	TID*085...
DMC086	8.6	5.4	●		1.74	TID*085...
DMC087	8.7	5.4	●		1.76	TID*085...
DMC088	8.8	5.4	●		1.78	TID*085...
DMC089	8.9	5.4	●		1.8	TID*085...
DMC090	9	5.8	●		1.91	TID*090...
DMC091	9.1	5.8	●		1.93	TID*090...
DMC092	9.2	5.8	●		1.95	TID*090...
DMC093	9.3	5.8	●		1.97	TID*090...
DMC094	9.4	5.8	●		1.99	TID*090...
DMC095	9.5	5.8	●		2.01	TID*095...
DMC096	9.6	5.8	●		2.03	TID*095...
DMC097	9.7	5.8	●		2.05	TID*095...
DMC098	9.8	5.8	●		2.07	TID*095...
DMC099	9.9	5.8	●		2.09	TID*095...
DMC100	10	6.67	●		2.09	TID*100...
DMC101	10.1	6.67	●		2.11	TID*100...
DMC102	10.2	6.67	●		2.13	TID*100...
DMC103	10.3	6.67	●		2.15	TID*100...
DMC104	10.4	6.67	●		2.17	TID*100...
DMC105	10.5	6.67	●		2.19	TID*105...
DMC106	10.6	6.67	●		2.21	TID*105...
DMC107	10.7	6.67	●		2.23	TID*105...
DMC108	10.8	6.67	●		2.25	TID*105...
DMC109	10.9	6.67	●		2.27	TID*105...
DMC110	11	7.1	●		2.32	TID*110...
DMC111	11.1	7.1	●		2.34	TID*110...
DMC112	11.2	7.1	●		2.36	TID*110...
DMC113	11.3	7.1	●		2.38	TID*110...
DMC114	11.4	7.1	●		2.4	TID*110...
DMC115	11.5	7.1	●		2.42	TID*115...

ø4 - ø19.9 = 2 pieces per package
ø20 - ø25.9 = 1 piece per package

● : New product
○ : Will be released in April 2022
● : Line up

P	Steel	★		
M	Stainless	★		
K	Cast iron	★		
N	Non-ferrous	☆		
S	Superalloys	★		
H	Hard materials	★		

P	Steel	★		
M	Stainless	★		
K	Cast iron	★		
N	Non-ferrous	☆		
S	Superalloys	★		
H	Hard materials	★		

★ : First choice
☆ : Second choice

Designation	DC	LPR	Coated		PL	Body
			AH9130			
DMC116	11.6	7.1	●		2.44	TID*115...
DMC117	11.7	7.1	●		2.46	TID*115...
DMC118	11.8	7.1	●		2.48	TID*115...
DMC119	11.9	7.1	●		2.5	TID*115...
DMC120	12	7.43	●		2.45	TID*120...
DMC121	12.1	7.43	●		2.47	TID*120...
DMC122	12.2	7.43	●		2.49	TID*120...
DMC123	12.3	7.43	●		2.51	TID*120...
DMC124	12.4	7.43	●		2.53	TID*120...
DMC125	12.5	7.43	●		2.55	TID*125...
DMC126	12.6	7.43	●		2.57	TID*125...
DMC127	12.7	7.43	●		2.59	TID*125...
DMC128	12.8	7.43	●		2.61	TID*125...
DMC129	12.9	7.43	●		2.63	TID*125...
DMC130	13	8.15	●		2.71	TID*130...
DMC131	13.1	8.15	●		2.73	TID*130...
DMC132	13.2	8.15	●		2.75	TID*130...
DMC133	13.3	8.15	●		2.77	TID*130...
DMC134	13.4	8.15	●		2.79	TID*130...
DMC135	13.5	8.15	●		2.81	TID*135...
DMC136	13.6	8.15	●		2.83	TID*135...
DMC137	13.7	8.15	●		2.85	TID*135...
DMC138	13.8	8.15	●		2.87	TID*135...
DMC139	13.9	8.15	●		2.89	TID*135...
DMC140	14	8.76	●		2.93	TID*140...
DMC141	14.1	8.76	●		2.95	TID*140...
DMC142	14.2	8.76	●		2.97	TID*140...
DMC143	14.3	8.76	●		2.99	TID*140...
DMC144	14.4	8.76	●		3.01	TID*140...
DMC145	14.5	8.76	●		3.03	TID*145...
DMC146	14.6	8.76	●		3.05	TID*145...
DMC147	14.7	8.76	●		3.07	TID*145...
DMC148	14.8	8.76	●		3.09	TID*145...
DMC149	14.9	8.76	●		3.11	TID*145...
DMC150	15	9.44	●		3.18	TID*150...
DMC151	15.1	9.44	●		3.2	TID*150...
DMC152	15.2	9.44	●		3.22	TID*150...
DMC153	15.3	9.44	●		3.24	TID*150...
DMC154	15.4	9.44	●		3.26	TID*150...
DMC155	15.5	9.44	●		3.28	TID*150...
DMC156	15.6	9.44	●		3.3	TID*150...
DMC157	15.7	9.44	●		3.32	TID*150...
DMC158	15.8	9.44	●		3.34	TID*150...
DMC159	15.9	9.44	●		3.36	TID*150...
DMC160	16	10.07	●		3.39	TID*160...
DMC161	16.1	10.07	●		3.41	TID*160...
DMC162	16.2	10.07	●		3.43	TID*160...
DMC163	16.3	10.07	●		3.45	TID*160...
DMC164	16.4	10.07	●		3.47	TID*160...
DMC165	16.5	10.07	●		3.49	TID*160...
DMC166	16.6	10.07	●		3.51	TID*160...
DMC167	16.7	10.07	●		3.53	TID*160...
DMC168	16.8	10.07	●		3.55	TID*160...
DMC169	16.9	10.07	●		3.57	TID*160...

Designation	DC	LPR	Coated		PL	Body
			AH9130			
DMC170	17	10.68	●		3.57	TID*170...
DMC171	17.1	10.68	●		3.59	TID*170...
DMC172	17.2	10.68	●		3.61	TID*170...
DMC173	17.3	10.68	●		3.63	TID*170...
DMC174	17.4	10.68	●		3.65	TID*170...
DMC175	17.5	10.68	●		3.67	TID*170...
DMC176	17.6	10.68	●		3.69	TID*170...
DMC177	17.7	10.68	●		3.71	TID*170...
DMC178	17.8	10.68	●		3.73	TID*170...
DMC179	17.9	10.68	●		3.75	TID*170...
DMC180	18	11.35	●		3.78	TID*180...
DMC181	18.1	11.35	●		3.8	TID*180...
DMC182	18.2	11.35	●		3.82	TID*180...
DMC183	18.3	11.35	●		3.84	TID*180...
DMC184	18.4	11.35	●		3.86	TID*180...
DMC185	18.5	11.35	●		3.88	TID*180...
DMC186	18.6	11.35	●		3.9	TID*180...
DMC187	18.7	11.35	●		3.92	TID*180...
DMC188	18.8	11.35	●		3.94	TID*180...
DMC189	18.9	11.35	●		3.96	TID*180...
DMC190	19	11.91	●		3.99	TID*190...
DMC191	19.1	11.91	●		4.01	TID*190...
DMC192	19.2	11.91	●		4.03	TID*190...
DMC1927	19.27	11.91	●		4.04	TID*190...
DMC193	19.3	11.91	●		4.05	TID*190...
DMC194	19.4	11.91	●		4.07	TID*190...
DMC195	19.5	11.91	●		4.09	TID*190...
DMC196	19.6	11.91	●		4.11	TID*190...
DMC197	19.7	11.91	●		4.13	TID*190...
DMC198	19.8	11.91	●		4.15	TID*190...
DMC199	19.9	11.91	●		4.17	TID*190...
DMC200	20	12.62	●		4.24	TID*200...
DMC201	20.1	12.62	●		4.26	TID*200...
DMC205	20.5	12.62	●		4.34	TID*200...
DMC206	20.6	12.62	●		4.36	TID*200...
DMC210	21	13.2	●		4.4	TID*210...
DMC211	21.1	13.2	●		4.42	TID*210...
DMC215	21.5	13.2	●		4.5	TID*210...
DMC217	21.7	13.2	●		4.54	TID*210...
DMC218	21.8	13.2	●		4.56	TID*210...
DMC220	22	13.84	●		4.6	TID*220...
DMC221	22.1	13.84	●		4.62	TID*220...
DMC222	22.2	13.84	●		4.64	TID*220...
DMC223	22.3	13.84	●		4.66	TID*220...
DMC225	22.5	13.84	●		4.7	TID*220...
DMC230	23	14.51	●		4.84	TID*230...
DMC235	23.5	14.51	●		4.94	TID*230...
DMC240	24	15.11	●		5.03	TID*240...
DMC245	24.5	15.11	●		5.13	TID*240...
DMC250	25	15.78	●		5.28	TID*250...
DMC253	25.3	15.78	●		5.34	TID*250...
DMC255	25.5	15.78	●		5.38	TID*250...
DMC2567	25.67	15.78	●		5.42	TID*250...
DMC259	25.9	15.78	●		5.46	TID*250...

ø4 - ø19.9 = 2 pieces per package
ø20 - ø25.9 = 1 piece per package

● : Line up

DMF Flat geometry head

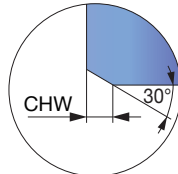
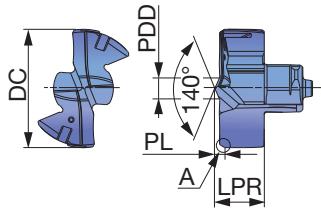
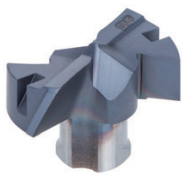

Detail in A

Tool diameter	Head diameter tolerance
ø6 - ø17.9	+0.018 / 0
ø18 - ø25.9	+0.021 / 0

P	Steel	★		
M	Stainless	★		
K	Cast iron	★		
N	Non-ferrous	☆		
S	Superalloys	★		
H	Hard materials	★		

P	Steel	★		
M	Stainless	★		
K	Cast iron	★		
N	Non-ferrous	☆		
S	Superalloys	★		
H	Hard materials	★		

★ : First choice
☆ : Second choice

Designation	DC	LPR	Coated		CHW	PL	PDD	Body
			AH9130					
DMF060	6	3.01	●		0.4	0.61	1.15	TID*060...
DMF065	6.5	3.28	●		0.4	0.68	1.54	TID*065...
DMF068	6.8	3.28	●		0.4	0.68	1.54	TID*065...
DMF070	7	3.58	●		0.4	0.68	1.54	TID*070...
DMF075	7.5	3.58	●		0.4	0.68	1.54	TID*075...
DMF080	8	4.39	●		0.7	1.09	2.44	TID*080...
DMF081	8.1	4.39	●		0.7	1.09	2.44	TID*080...
DMF085	8.5	4.39	●		0.7	1.09	2.44	TID*085...
DMF086	8.6	4.39	●		0.7	1.09	2.44	TID*085...
DMF087	8.7	4.39	●		0.7	1.09	2.44	TID*085...
DMF088	8.8	4.39	●		0.7	1.09	2.44	TID*085...
DMF090	9	4.61	●		0.7	1.11	2.55	TID*090...
DMF095	9.5	4.61	●		0.7	1.11	2.55	TID*095...
DMF100	10	4.72	●		0.7	1.17	2.89	TID*100...
DMF101	10.1	4.72	●		0.7	1.17	2.89	TID*100...
DMF103	10.3	4.72	●		0.7	1.17	2.89	TID*100...
DMF104	10.4	4.72	●		0.7	1.17	2.89	TID*100...
DMF105	10.5	4.72	●		0.7	1.17	2.89	TID*105...
DMF106	10.6	4.72	●		0.7	1.17	2.89	TID*105...
DMF107	10.7	4.72	●		0.7	1.17	2.89	TID*105...
DMF108	10.8	4.72	●		0.7	1.17	2.89	TID*105...
DMF110	11	4.9	●		0.7	1.25	2.98	TID*110...
DMF115	11.5	4.9	●		0.7	1.25	2.98	TID*115...
DMF117	11.7	4.9	●		0.7	1.25	2.98	TID*115...
DMF120	12	5.21	●		0.7	1.26	3.13	TID*120...
DMF121	12.1	5.21	●		0.7	1.26	3.13	TID*120...
DMF122	12.2	5.21	●		0.7	1.26	3.13	TID*120...
DMF123	12.3	5.21	●		0.7	1.26	3.13	TID*120...
DMF124	12.4	5.21	●		0.7	1.26	3.13	TID*120...
DMF125	12.5	5.21	●		0.7	1.26	3.13	TID*125...
DMF126	12.6	5.21	●		0.7	1.26	3.13	TID*125...
DMF127	12.7	5.21	●		0.7	1.26	3.13	TID*125...
DMF130	13	5.53	●		0.7	1.28	3.52	TID*130...
DMF131	13.1	5.53	●		0.7	1.28	3.52	TID*130...
DMF133	13.3	5.53	●		0.7	1.28	3.52	TID*130...
DMF135	13.5	5.53	●		0.7	1.28	3.52	TID*135...
DMF137	13.7	5.53	●		0.7	1.28	3.52	TID*135...
DMF138	13.8	5.53	●		0.7	1.28	3.52	TID*135...
DMF139	13.9	5.53	●		0.7	1.28	3.52	TID*135...

Designation	DC	LPR	Coated		CHW	PL	PDD	Body
			AH9130					
DMF140	14	5.96	●		0.7	1.31	3.81	TID*140...
DMF141	14.1	5.96	●		0.7	1.31	3.81	TID*140...
DMF142	14.2	5.96	●		0.7	1.31	3.81	TID*140...
DMF143	14.3	5.96	●		0.7	1.31	3.81	TID*140...
DMF144	14.4	5.96	●		0.7	1.31	3.81	TID*140...
DMF145	14.5	5.96	●		0.7	1.31	3.81	TID*145...
DMF150	15	6.43	●		0.7	1.35	4.24	TID*150...
DMF152	15.2	6.43	●		0.7	1.35	4.24	TID*150...
DMF155	15.5	6.43	●		0.7	1.35	4.24	TID*150...
DMF157	15.7	6.43	●		0.7	1.35	4.24	TID*150...
DMF158	15.8	6.43	●		0.7	1.35	4.24	TID*150...
DMF160	16	6.84	●		0.7	1.39	4.06	TID*160...
DMF161	16.1	6.84	●		0.7	1.39	4.06	TID*160...
DMF165	16.5	6.84	●		0.7	1.39	4.06	TID*160...
DMF167	16.7	6.84	●		0.7	1.39	4.06	TID*160...
DMF170	17	7.15	●		0.7	1.4	4.14	TID*170...
DMF175	17.5	7.15	●		0.7	1.4	4.14	TID*170...
DMF179	17.9	7.15	●		0.7	1.4	4.14	TID*170...
DMF180	18	7.45	●		0.7	1.42	4.16	TID*180...
DMF185	18.5	7.45	●		0.7	1.42	4.16	TID*180...
DMF190	19	7.79	●		0.7	1.44	4.25	TID*190...
DMF195	19.5	7.79	●		0.7	1.44	4.25	TID*190...
DMF198	19.8	7.79	●		0.7	1.44	4.25	TID*190...
DMF200	20	10.19	○		0.7	1.77	6.56	TID*200...
DMF205	20.5	10.19	○		0.7	1.77	6.56	TID*200...
DMF210	21	10.63	○		0.7	1.79	6.92	TID*210...
DMF215	21.5	10.63	○		0.7	1.79	6.92	TID*210...
DMF218	21.8	10.63	○		0.7	1.79	6.92	TID*210...
DMF220	22	10.97	○		0.7	1.81	7.13	TID*220...
DMF225	22.5	10.97	○		0.7	1.81	7.13	TID*220...
DMF230	23	11.41	○		0.7	1.83	7.42	TID*230...
DMF235	23.5	11.41	○		0.7	1.83	7.42	TID*230...
DMF240	24	11.87	○		0.7	1.86	7.45	TID*240...
DMF245	24.5	11.87	○		0.7	1.86	7.45	TID*240...
DMF250	25	12.35	○		0.7	1.9	7.54	TID*250...
DMF254	25.4	12.35	○		0.7	1.9	7.54	TID*250...
DMF255	25.5	12.35	○		0.7	1.9	7.54	TID*250...
DMF259	25.9	12.35	○		0.7	1.9	7.54	TID*250...

○ : Will be released in January 2022
● : Line up

ø6 - ø19.9 = 2 pieces per package
ø20 - ø25.9 = 1 piece per package

DMH High strength cutting edge

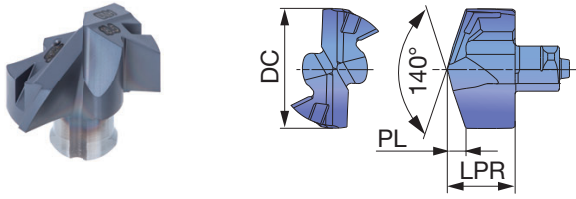

Tool diameter	Head diameter tolerance
ø6 - ø25.5	±0.01

P	Steel	★		
M	Stainless	★		
K	Cast iron	★		
N	Non-ferrous			
S	Superalloys	★		
H	Hard materials	★		

P	Steel	★		
M	Stainless	★		
K	Cast iron	★		
N	Non-ferrous			
S	Superalloys	★		
H	Hard materials	★		

★ : First choice
☆ : Second choice

Designation	DC	LPR	Coated		PL	Body
			AH9130			
New DMH060	6	3.85	●		1.09	TID*060..
New DMH068	6.8	4.15	●		1.33	TID*065...
New DMH070	7	4.45	●		1.03	TID*070..
New DMH075	7.5	4.45	●		1.12	TID*075..
New DMH080	8	5.25	●		1.2	TID*080..
New DMH085	8.5	5.25	●		1.29	TID*085..
New DMH086	8.6	5.25	●		1.31	TID*085..
New DMH087	8.7	5.25	●		1.33	TID*085..
New DMH088	8.8	5.25	●		1.35	TID*085..
New DMH090	9	5.65	●		1.37	TID*090..
New DMH095	9.5	5.65	●		1.46	TID*095..
New DMH097	9.7	5.65	●		1.5	TID*095..
DMH100	10	6.05	●		1.47	TID*100...
DMH103	10.3	6.05	●		1.52	TID*100...
DMH105	10.5	6.05	●		1.56	TID*105...
DMH108	10.8	6.05	●		1.62	TID*105...
DMH110	11	6.45	●		1.67	TID*110...
DMH115	11.5	6.45	●		1.76	TID*115...
DMH120	12	6.8	●		1.82	TID*120...
DMH125	12.5	6.8	●		1.91	TID*125...
DMH126	12.6	6.8	●		1.93	TID*125...
DMH130	13	7.4	●		1.96	TID*130...
DMH133	13.3	7.4	●		2.01	TID*130...
DMH135	13.5	7.4	●		2.05	TID*135...
DMH137	13.7	7.4	●		2.09	TID*135...
DMH138	13.8	7.4	●		2.11	TID*135...
DMH139	13.9	7.4	●		2.12	TID*135...
DMH140	14	7.95	●		2.12	TID*140...
DMH142	14.2	7.95	●		2.16	TID*140...
DMH145	14.5	7.95	●		2.21	TID*145...
DMH150	15	8.53	●		2.27	TID*150...
DMH152	15.2	8.53	●		2.31	TID*150...
DMH155	15.5	8.53	●		2.36	TID*150...
DMH160	16	9.1	●		2.42	TID*160...
DMH165	16.5	9.1	●		2.51	TID*160...
DMH170	17	9.7	●		2.59	TID*170...
DMH175	17.5	9.7	●		2.68	TID*170...
DMH180	18	10.3	●		2.73	TID*180...
DMH185	18.5	10.3	●		2.82	TID*180...

Designation	DC	LPR	Coated		PL	Body
			AH9130			
DMH190	19	10.8	●		2.88	TID*190...
DMH194	19.4	10.8	●		2.95	TID*190...
DMH195	19.5	10.8	●		2.97	TID*190...
New DMH200	20	11.4	●		3.02	TID*200...
New DMH205	20.5	11.4	●		3.11	TID*200...
New DMH210	21	11.98	●		3.18	TID*210...
New DMH215	21.5	11.98	●		3.27	TID*210...
New DMH220	22	12.56	●		3.32	TID*220..
New DMH225	22.5	12.56	●		3.41	TID*220..
New DMH230	23	13.13	●		3.46	TID*230...
New DMH235	23.5	13.13	●		3.55	TID*230...
New DMH240	24	13.7	●		3.62	TID*240..
New DMH245	24.5	13.7	●		3.71	TID*240..
New DMH250	25	14.3	●		3.8	TID*250...
New DMH255	25.5	14.3	●		3.89	TID*250...

● : New product
● : Line up

ø6 - ø19.9 = 2 pieces per package
ø20 - ø25.5 = 1 piece per package

DMN Non-ferrous metals drilling

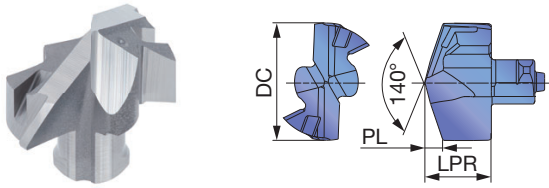

Tool diameter	Head diameter tolerance
ø10 - ø17.5	+0.01 / 0
ø18 - ø19.9	+0.012 / 0

P	Steel			
M	Stainless			
K	Cast iron			
N	Non-ferrous	★		
S	Superalloys			
H	Hard materials			

★ : First choice
☆ : Second choice

Designation	DC	LPR	Coated		PL	Body
			KS15F			
DMN100	10	6.05	●		1.47	TID*100...
DMN102	10.2	6.05	●		1.51	TID*100...
DMN105	10.5	6.05	●		1.56	TID*105...
DMN108	10.8	6.05	●		1.62	TID*105...
DMN110	11	6.45	●		1.67	TID*110...
DMN115	11.5	6.45	●		1.76	TID*115...
DMN120	12	6.8	●		1.82	TID*120...
DMN123	12.3	6.8	●		1.87	TID*120...
DMN125	12.5	6.8	●		1.91	TID*125...
DMN126	12.6	6.8	●		1.93	TID*125...
DMN127	12.7	6.8	●		1.95	TID*125...
DMN130	13	7.4	●		1.96	TID*130...
DMN135	13.5	7.4	●		2.05	TID*135...
DMN138	13.8	7.4	●		2.11	TID*135...
DMN140	14	7.95	●		2.12	TID*140...
DMN142	14.2	7.95	●		2.16	TID*140...
DMN145	14.5	7.95	●		2.21	TID*145...
DMN150	15	8.53	●		2.27	TID*150...
DMN152	15.2	8.53	●		2.31	TID*150...
DMN155	15.5	8.53	●		2.36	TID*150...
DMN158	15.8	8.53	●		2.42	TID*150...
DMN159	15.9	8.53	●		2.43	TID*150...
DMN160	16	9.1	●		2.42	TID*160...
DMN163	16.3	9.1	●		2.47	TID*160...
DMN165	16.5	9.1	●		2.51	TID*160...
DMN170	17	9.7	●		2.59	TID*170...
DMN175	17.5	9.7	●		2.68	TID*170...
DMN180	18	10.3	●		2.73	TID*180...
DMN185	18.5	10.3	●		2.82	TID*180...
DMN190	19	10.8	●		2.88	TID*190...
DMN195	19.5	10.8	●		2.97	TID*190...

ø10 - ø19.5 = 2 pieces per package

● : Line up

STANDARD CUTTING CONDITIONS

ISO	Workpiece material	Cutting speed Vc (m/min)	Feed: f (mm/rev)									
			Tool diameter: DC (mm)									
			ø4 - 4.4	ø4.5 - 4.9	ø5 - 5.9	ø6 - 7.9	ø8 - 9.9	ø10 - ø11.9	ø12 - ø13.9	ø14 - ø15.9	ø16 - ø19.9	ø20 - ø25.9
P	Low carbon steels (C < 0.3) SS400, SM490, S25C, etc. C15E4, E275A, E355D, etc.	80 - 140	0.04 - 0.07	0.04 - 0.08	0.07 - 0.13	0.09 - 0.13	0.12 - 0.25	0.15 - 0.28	0.18 - 0.3	0.20 - 0.35	0.25 - 0.45	0.25 - 0.45
	High carbon steels (C > 0.3) S45C, S55C, etc. C45, C55, etc.	70 - 120	0.04 - 0.07	0.04 - 0.08	0.07 - 0.13	0.09 - 0.13	0.12 - 0.25	0.15 - 0.28	0.18 - 0.3	0.2 - 0.35	0.25 - 0.45	0.25 - 0.45
	Low alloy steels SCM415, etc. 18CrMo4, etc.	70 - 120	0.04 - 0.06	0.05 - 0.08	0.07 - 0.13	0.08 - 0.13	0.11 - 0.25	0.14 - 0.28	0.16 - 0.32	0.18 - 0.35	0.23 - 0.4	0.25 - 0.45
	Alloy steels SCM440, SCR420, etc. 42CrMo4, 20Cr4, etc.	40 - 90	0.04 - 0.07	0.05 - 0.08	0.07 - 0.13	0.08 - 0.13	0.11 - 0.25	0.14 - 0.28	0.16 - 0.32	0.18 - 0.35	0.23 - 0.4	0.25 - 0.45
M	Stainless steels SUS304, SUS316, etc. X5CrNi18-9, X5CrNiMo17-12-2, etc.	30 - 70	-	-	0.04 - 0.08	0.08 - 0.1	0.1 - 0.15	0.12 - 0.18	0.14 - 0.2	0.16 - 0.24	0.16 - 0.26	0.18 - 0.3
K	Grey cast irons FC250, etc. GG25, etc.	80 - 180	0.04 - 0.08	0.04 - 0.08	0.1 - 0.15	0.12 - 0.18	0.15 - 0.3	0.20 - 0.35	0.25 - 0.4	0.3 - 0.45	0.35 - 0.55	0.35 - 0.6
	Ductile cast irons FCD700, etc. GGG70, etc.	80 - 140	0.04 - 0.08	0.04 - 0.08	0.1 - 0.15	0.12 - 0.18	0.15 - 0.3	0.20 - 0.35	0.25 - 0.4	0.3 - 0.45	0.35 - 0.55	0.35 - 0.6
N	Aluminium alloys ADC12, etc. AlSi11Cu3, etc.	80 - 220	-	-	-	0.1 - 0.2	0.2 - 0.35	0.25 - 0.4	0.3 - 0.45	0.35 - 0.5	0.4 - 0.6	0.5 - 0.75
S	Titanium alloys Ti-6Al-4V, etc.	20 - 50	-	-	-	0.05 - 0.07	0.06 - 0.12	0.08 - 0.15	0.1 - 0.28	0.12 - 0.2	0.14 - 0.22	0.18 - 0.27
	Nickel-based alloys	20 - 50	-	-	-	0.05 - 0.07	0.06 - 0.11	0.08 - 0.13	0.1 - 0.15	0.12 - 0.18	0.12 - 0.22	0.14 - 0.22
H	Hardened steel	20 - 50	-	-	-	0.05 - 0.07	0.06 - 0.12	0.08 - 0.15	0.1 - 0.18	0.12 - 0.2	0.14 - 0.22	0.16 - 0.25

- Cutting conditions in the above table show standard cutting conditions
- Cutting conditions may change due to the rigidity and power of the machine and the workpiece material
- Machined hole diameter may change depending upon the rigidity of the machine tool or cutting conditions

Over 2xD drilling without internal coolant

At without internal coolant environment, external coolant supply is required. The cutting condition is recommended to reduced from listed condition depend on material and hole depth. Over 2xD drill, Step or pecking cycle operation is recommended in order to cooling cutting edge and chip evacuation.

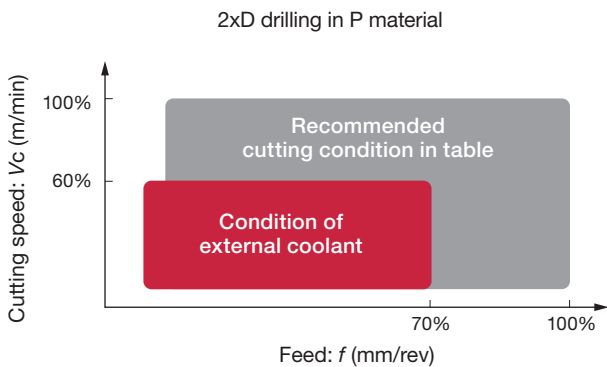

Over 8xD drilling

Drilling operation with over 8xD drilling require stable drill entry. To proof excellent drill entry. DMC head is recommended. Also incase of L/D=8, 12 drilling, the recommended of cutting speed and feeds in between the minimum and medium value listed above at drill entry first few depth. After drill entry, possible to increase feed depend on target productivity.

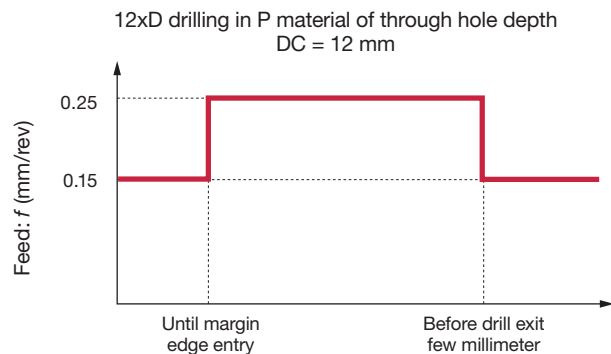

TECHNICAL GUIDE

● Drilling head mounting procedure

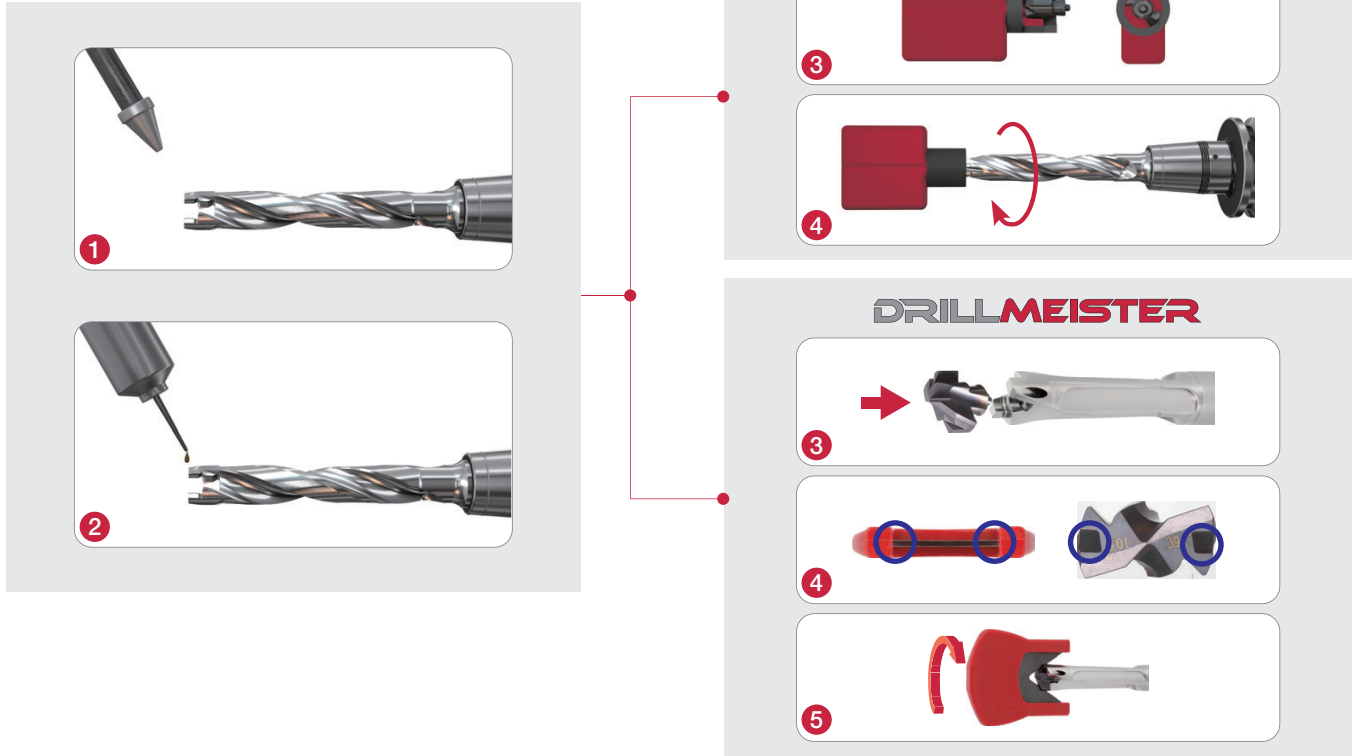

● Instruction for proper head mounting

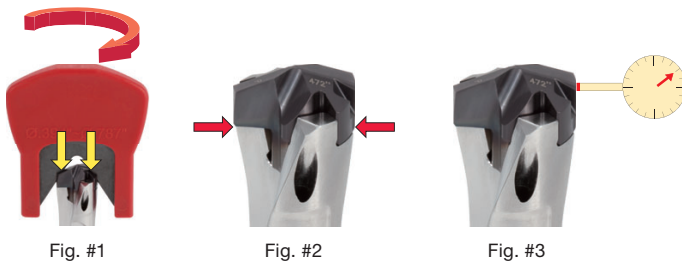

Procedures

- ① Thoroughly clean the contacting areas on the drill body and the head with compressed air, lubricate them, and put the drill head in the pocket.
- ② Place the clamping key in the grooves on the drill head. Push the head in the pocket with equal torque on the right and the left sides. Rotate the clamping key to lock the head in the pocket completely. (Fig. #1).
- ③ Be sure that there is no gap in the contact surfaces between the head and the drill body. Use a 0.01 mm shim to check for the gap. (Fig. #2)
- ④ If there is a gap thicker than 0.01 mm, unclamp the head and return to procedure No. ①.
- ⑤ Measure the run-out at the margin of the drill head. Run-out must be 0.05 mm or smaller. (Fig. #3) (Recommended value: 0.02 mm or smaller)
If the run-out exceeds 0.05 mm, unclamp the head and return to procedure No. ①.

Note: #1: If the clamping torque is not equally applied on the right and the left sides of the drill head, there may be a gap between the head and the body, which increases the run-out of the head.

Note: #2: Low accuracy in holding the drill body may affect the run-out. If the run-out is large, check the accuracy in holding the drill body.

● Alignment recommendation

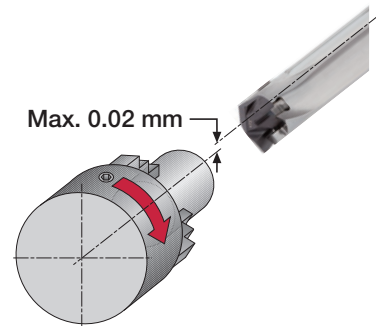

● Runout recommendation



ADDMEISTERDRILL
Max. 0.02 mm

DRILLMEISTER
Ideal : ≤ 0.02 mm
Acceptable : ≤ 0.05 mm
Not acceptable : > 0.05 mm

● Coolant recommendation

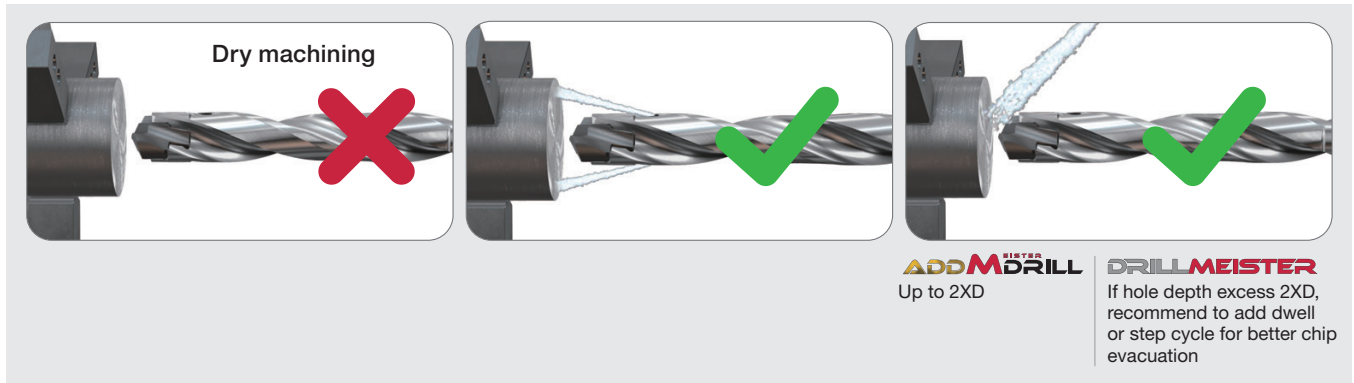

● Recommended coolant flow rate and pressures

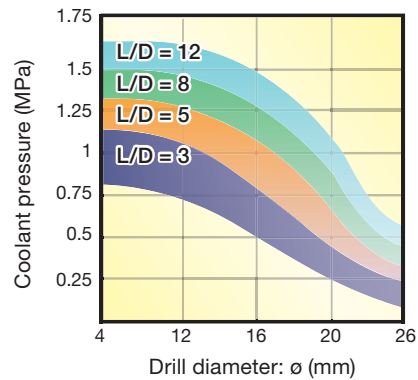
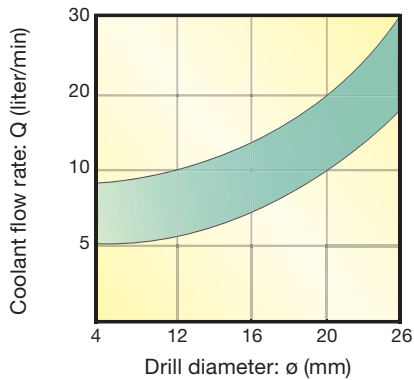

● Application range and recommended tool lengths for application irregularities

Please use the shortest tool length possible

Application	Stacked plate	Complex exit	Rough / cast surface	Inclined surface	OK
					Impossible
ADD M DRILL	X	X	X	X	
DRILLMEISTER	✓	✓ Up to 8xD	✓ Up to 5xD	✓ Up to 3xD	
Application	Curved surface	Hole expansion	Plunging	Counter boring	OK
					Impossible
ADD M DRILL	X	X	X	X	
DRILLMEISTER	✓ Up to 3xD	✓ Up to 3xD	✓ Up to 3xD	X	

● Tips when using 8xD and 12xD drills

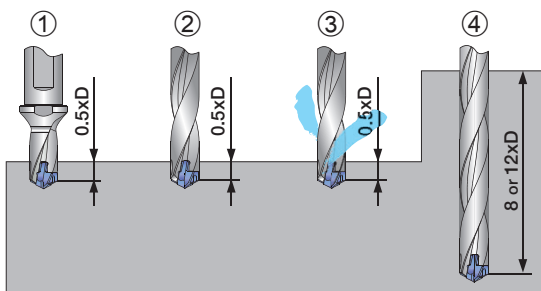

- ① Drill a pilot hole in the depth of 0.5xD.
The same head diameter should be used for the pre-hole and the main drilling process.
- ② Rotate the drill at a low speed (eg. 100 rpm). While maintaining the drill speed, slowly feed into the pilot hole for several millimeters from the entry.
- ③ Activate the internal coolant and increase the drill rotation to the required speed.
- ④ Drill to the required depth using the recommended cutting parameters.

Note: Use DMC-style drill head for deep holes from 8xD up to 12xD depths without a pilot hole.

● Head combinations of pre-hole to main hole

		Pre-hole		
		DMP	DMC	DMF
Hole	DMP	Good 	Not good 	Not good
	DMC	Good 	Good 	Good
	DMF	Not good 	Not good 	Good

● Holders recommended for M/C

TID-F...

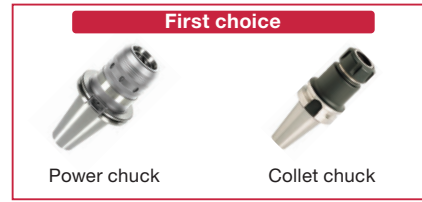

TID-R...



Note: If you need to use a 12xD body with a side-lock holder, the shank will need to have a flat area which may be placed additionally.

● When to change drill heads (Criteria for the end of tool life)

Replace the drill head when the following phenomena occur during the machining:

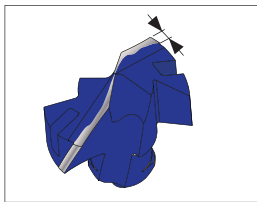

Width of corner wear reaches

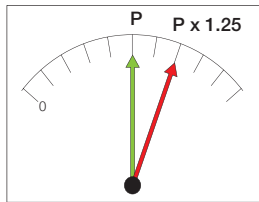

Spindle load exceeds 125% of the normal value

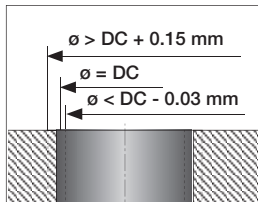

Hole diameter is 0.15 mm larger or 0.03 mm smaller than the drill diameter

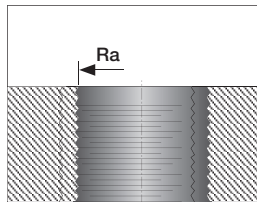

Surface roughness deterioration

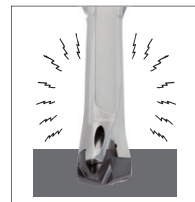

Vibration or unusual noise

DRILLMEISTER : 0.2 - 0.3 mm
ADDMEISTERDRILL : 0.1 - 0.2 mm

● When to change drill heads (Criteria for the end of tool life)

For your safety, it is recommended to replace drill bodies that reached the fatigue life with new drill bodies. To determine the fatigue life, Measure the torque value required to unlock the drill head with a torque driver. When the torque value required is equal to or smaller than the values listed below for respective head sizes, replace the drill body with a new one.

Clamping key for measuring un-clamping torque:
KHS-TID10-19.99







* The clamping key can be connect with general torque drivers.



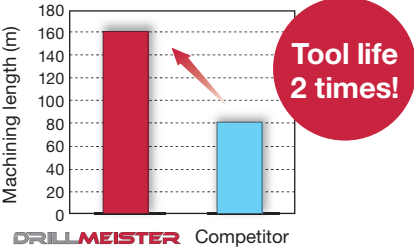
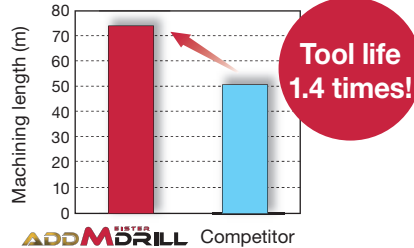

Head Designation	Recommended value of un-clamping torque that means usable limit of a drill body	
	(N·m)	(cN·m)
DM*100-109	0.2	20
DM*110-119	0.2	20
DM*120-129	0.25	25
DM*130-139	0.25	25
DM*140-149	0.3	30
DM*150-159	0.3	30
DM*160-169	0.35	35
DM*170-179	0.35	35
DM*180-189	0.4	40
DM*190-199	0.4	40

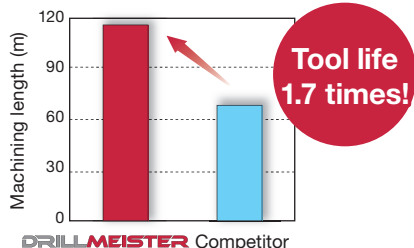
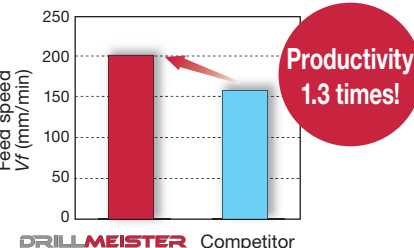
PRACTICAL EXAMPLES

Workpiece type		Cylinder block	Flange part
Drill body		TID115F16-8	TID050R06-5
Head		DMC115	DMP050
Grade		AH9130	AH725
Workpiece material		FC250 / GG25 / 250  K	S45C / C45  P
Cutting conditions	Cutting speed : V_c (m/min)	100	100
	Feed : f (mm/rev)	0.2	0.1
	Feed speed : V_f (mm/min)	554	636.9
	Drill diameter : ϕD_c (mm)	11.5	5
	Hole depth : H (mm)	80	20
	Coolant	Wet (Internal coolant)	Wet (Internal and external coolant)
Machine		Horizontal M/C	Vertical M/C
Results		 <p>DRILLMEISTER Competitor</p> <p>Competitor' tool has been broken sometime due to bending holes. DMC heads provides the machining stability by self centering geometry and double margins. AH9130 grade achieved 2 times longer tool life than competitor even in higher cutting speed.</p>	 <p>ADDMEISTER DRILL Competitor</p> <p>Combination of sharp cutting edge and efficient coolant supply shown 1.4 times better tool life than solid drill.</p>
Workpiece type		Out put shaft	Flange part
Drill body		TIDC160C16-5	TIDC100C10-3
Head		DMP165	DMP105
Grade		AH9130	AH725
Workpiece material		SCr420 / 20Cr4  P	SUS304 / X5CrNi18-9  M
Cutting conditions	Cutting speed : V_c (m/min)	80	45
	Feed : f (mm/rev)	0.3	0.15
	Feed speed : V_f (mm/min)	463.2	205
	Drill diameter : ϕD_c (mm)	16.5	10.5
	Hole depth : H (mm)	50	23
	Coolant	Wet (Internal coolant)	Wet (Internal coolant)
Machine		Vertical M/C	Horizontal M/C
Results		 <p>DRILLMEISTER Competitor</p> <p>Compared to the competitor's similar product, DrillMeister extends tool life by 1.7 times.</p>	 <p>DRILLMEISTER Competitor</p> <p>DrillMeister allows high-feed machining and increases productivity by 1.3 times. AH725 with good chipping resistance extends tool life by 30%.</p>

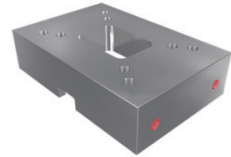
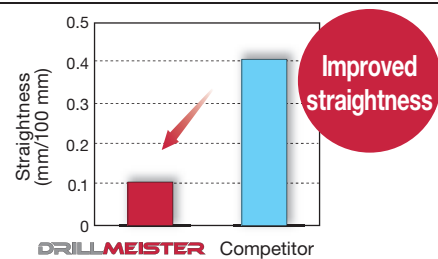
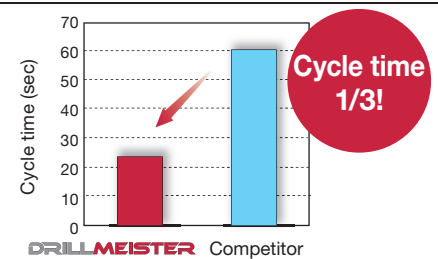
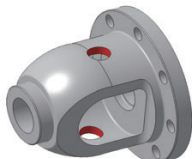
PRACTICAL EXAMPLES

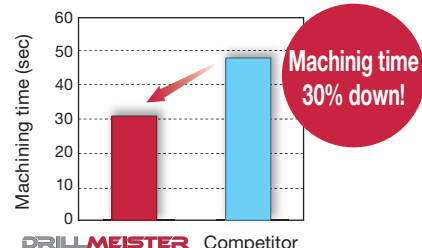
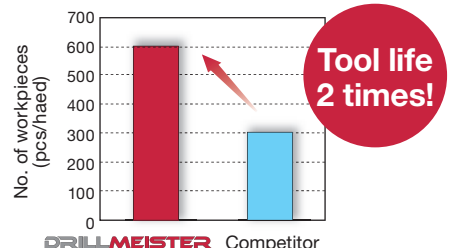
Workpiece type		Out put shaft	Mold base	
Drill body		TID140F16-8	TID180R25-12	
Head		DMC140	DMC180	
Grade		AH9130	AH9130	
Workpiece material		SCM415  P	S55C / C55  P	
Cutting conditions	Cutting speed : V_c (m/min)	120	120	
	Feed : f (mm/rev)	0.3	0.25	
	Feed speed : V_f (mm/min)	600	531	
	Drill diameter: ϕD_c (mm)	14	18	
	Hole depth : H (mm)	80	200	
	Coolant	Wet (Internal coolant)		
Machine		Horizontal M/C		
Results	 <p>With the competitor's drill, the hole quality could not satisfy the straightness required. DrillMeister's DMC drill head improved the hole straightness to 1/4 of the competitor's.</p>		 <p>DMC does not need a guide hole. DMC achieved 3 times higher productivity than current process by eliminating a guide hole process and increasing cutting speed and feed rate.</p>	
	Workpiece type		Deff case	Wheel hub
Drill body		TID145F16-5	TID135R14-3.5	
Head		DMF145	DMH137	
Grade		AH9130	AH9130	
Workpiece material		FCD600 / GGG60 / 600-3  K	S40C  P	
Cutting conditions	Cutting speed : V_c (m/min)	100	150	
	Feed : f (mm/rev)	0.25	0.32	
	Feed speed : V_f (mm/min)	594	115.8	
	Drill diameter: ϕD_c (mm)	14.5	13.7	
	Hole depth : H (mm)	20	15	
	Coolant	Wet (Internal coolant)		
Machine		Vertical M/C		
Results	 <p>DMF head help to consolidates spot facing and drilling operations to casted uneven surface in order to Improve machining time.</p>		 <p>The combination of reinforce geometry DMH and advanced wear resistant grade AH9130 show double tool life.</p>	

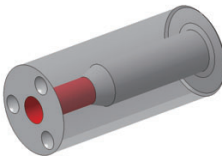
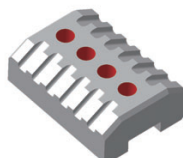
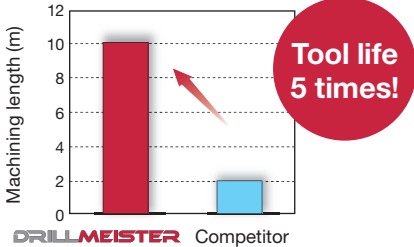
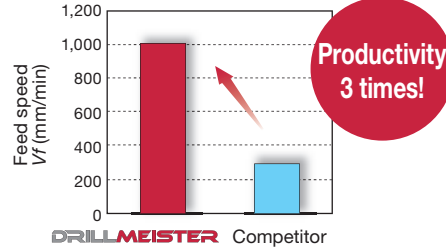
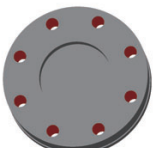
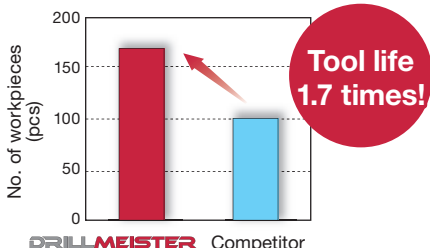
Workpiece type		Mold	Electric part
Drill body		TID170F20-5	TID140F15-3
Head		DMC170	DMN142
Grade		AH9130	KS15F
Workpiece material		SKD11 (50HRC)	A5052
		 H	 N
Cutting conditions	Cutting speed : V_c (m/min)	30	135
	Feed : f (mm/rev)	0.2	0.33
	Feed speed : V_f (mm/min)	112	1,000
	Drill diameter: ϕD_c (mm)	17	14.2
	Hole depth : H (mm)	80	15
	Coolant	Wet (Internal coolant)	Wet (Internal coolant)
	Machine	Swiss lathe	Vertical M/C
Results	 <p>DRILLMEISTER Competitor</p> <p>Compare against indexable drill, DMC show 5 times better tool life due to high wear restraint grade AH9130.</p>		 <p>DRILLMEISTER Competitor</p> <p>3 times better productivity achieved due to dedite head can be applied with same tool body.</p>
Workpiece type		Manufacturing machine part	
Drill body		TID065F12-1.5	
Head		DMP069	
Grade		AH725	
Workpiece material		Ni alloy	
		 S	
Cutting conditions	Cutting speed : V_c (m/min)	54	
	Feed : f (mm/rev)	0.08	
	Feed speed : V_f (mm/min)	199.4	
	Drill diameter: ϕD_c (mm)	6.9	
	Hole depth : H (mm)	5.1	
	Coolant	Wet (Internal coolant)	
Machine	Horizontal M/C		
Results	 <p>DRILLMEISTER Competitor</p> <p>1.7 times better tool life achived than competitor head chanagble drill due to low cutting force and good chip evaquation</p>		

Tungaloy Corporation (Head office)

11-1 Yoshima-Kogyodanchi
Iwaki-city, Fukushima 970-1144 Japan
Phone: +81-246-36-8501
Fax: +81-246-36-8542
www.tungaloy.co.jp

Tungaloy America, Inc.

3726 N Ventura Drive
Arlington Heights, IL 60004, U.S.A.
Phone: +1-888-554-8394
Fax: +1-888-554-8392
www.tungaloy.com/us

Tungaloy Canada

432 Elgin St. Unit 3
Brantford, Ontario N3S 7P7, Canada
Phone: +1-519-758-5779
Fax: +1-519-758-5791
www.tungaloy.com/ca

Tungaloy de Mexico S.A.

C. Los Arellano 113,
Parque Industrial Siglo XXI
Aguascalientes, AGS, Mexico 20290
Phone: +52-449-929-5410
Fax: +52-449-929-5411
www.tungaloy.com/mx

Tungaloy do Brasil Ltda.

Avd. Independencia N4158 Residencial Flora
13280-000 Vinhedo, São Paulo, Brasil
Phone: +55-19-38262757
Fax: +55-19-38262757
www.tungaloy.com/br

Tungaloy Germany GmbH

An der Alten Ziegelei 1
D-40789 Monheim, Germany
Phone: +49-2173-90420-0
Fax: +49-2173-90420-19
www.tungaloy.com/de

Tungaloy France S.A.S.

ZA Courtaboeuf - Le Rio
1 rue de la Terre de feu
F-91952 Courtaboeuf Cedex, France
Phone: +33-1-6486-4300
Fax: +33-1-6907-7817
www.tungaloy.com/fr

Tungaloy Italia S.r.l.

Via E. Andolfato 10
I-20126 Milano, Italy
Phone: +39-02-252012-1
Fax: +39-02-252012-65
www.tungaloy.com/it

Tungaloy Czech s.r.o.

Turanka 115
CZ-627 00 Brno, Czech Republic
Phone: +420-532 123 391
Fax: +420-532 123 392
www.tungaloy.com/cz

Tungaloy Ibérica S.L.

C/Miquel Servet, 43B, Nau 7
Pol. Ind. Bufalvent
ES-08243 Manresa (BCN), Spain
Phone: +34 93 113 1360
Fax: +34 93 876 2798
www.tungaloy.com/es

Tungaloy Scandinavia AB

Bultgatan 38
442 40 Kungälv, Sweden
Phone: +46-462119200
Fax: +46-462119207
www.tungaloy.com/se

Tungaloy Rus, LLC

Andropova avenue, h.18/7,
11 floor, office 3, 115432,
Moscow, Russia
Phone: +7-499-683-01-80
Fax: +7-499-683-01-81
www.tungaloy.com/ru

Tungaloy Polska Sp. z o.o.

Ul. Irysowa 1, 55-040 Bielany
Wroclawskie, Poland
Phone: +48 607 907 237
www.tungaloy.com/pl

Tungaloy U.K. Ltd

Gallan Park, Watling Street,
Cannock, WS110XG, UK
Phone: +44 121 4000 231
Fax: +44 121 270 9694
www.tungaloy.com/uk

Tungaloy Hungary Kft

Erzsébet királyné útja 125
H-1142 Budapest, Hungary
Phone: +36 1 781-6846
Fax: +36 1 781-6866
www.tungaloy.com/hu

Tungaloy Turkey

Serifali Mah.bayraktar Bulvari Kule Sk. No:26
34775 Umraniye / Istanbul / Turkey
Phone: +90 216 540 04 67
Fax: +90 216 540 04 87
www.tungaloy.com/tr

Tungaloy Benelux b.v.

Tjalk 70
NL-2411 NZ Bodegraven, Netherlands
Phone: +31 172 630 420
Fax: +31 172 630 429
www.tungaloy.com/nl

Tungaloy Croatia

Ulica bana Josipa Jelačića 87,
10430, Samobor, Croatia
Phone: +385 1 3326 604
Fax: +385 1 3327 683
www.tungaloy.com/hr

Tungaloy Cutting Tool (Shanghai) Co.,Ltd.

Rm No 401 No.88 Zhabei
Jiangchang No.3 Rd
Shanghai 200436, China
Phone: +86-21-3632-1880
Fax: +86-21-3621-1918
www.tungaloy.com/cn

Tungaloy Cutting Tools (Taiwan) Co.,Ltd.

9F. No.293, Zhongyang Rd,
Xinzhuan Dist, New Taipei City,
24251 Taiwan
Phone: +886-2-8521-9986
Fax: +886-2-8521-8935
www.tungaloy.com/tw

Tungaloy Cutting Tools (Thailand) Co.,Ltd.

Interlink tower 4th Fl.
1858/5-7 Bangna-Trad Road
km.5 Bangna, Bangna, Bangkok 10260
Thailand
Phone: +66-2-751-5711
Fax: +66-2-751-5715
www.tungaloy.com/th

Tungaloy Singapore (Pte.), Ltd.

62 Ubi Road 1, #06-11 Oxley BizHub 2
Singapore 408734
Phone: +65-6391-1833
Fax: +65-6299-4557
www.tungaloy.com/sing

Tungaloy Vietnam

LE04.38, Lexington Residence
67 Mai Chi Tho St., Dist. 2,
Ho Chi Minh City, Vietnam
Phone: +84-2837406660
www.tungaloy.com/sing

Tungaloy India Pvt. Ltd.

One International Center,
Unit # 902-A, 9th Floor,
Tower 1, Senapati Bapat Marg,
Elphinstone Road (West),
Mumbai-400013, India
Phone: +91-22-6124-8804
Fax: +91-22-6124-8899
www.tungaloy.com/in

Tungaloy Korea Co., Ltd

#1312, Byucksan Digital Valley 5-cha
Beotkkot-ro 244, Geumcheon-gu
153-788 Seoul, Korea
Phone: +82-2-2621-6161
Fax: +82-2-6393-8952
www.tungaloy.com/kr

Tungaloy Malaysia Sdn Bhd

50 K-2, Kelana Mall, Jalan SS6/14
Kelana Jaya, 47301
Petaling Jaya, Selangor Darul Ehsan
Malaysia
Phone: +603-7805-3222
Fax: +603-7804-8563
www.tungaloy.com/my

Tungaloy Australia Pty Ltd

Unit 68 1470 Ferntree Gully Road
Knoxfield 3180 Victoria, Australia
Phone: +61-3-9755-8147
Fax: +61-3-9755-6070
www.tungaloy.com/au

PT. Tungaloy Indonesia

Kompleks Grand Wisata Block AA-10 No.3-5
Cibitung
Bekasi 17510, Indonesia
Phone: +62-21-8261-5808
Fax: +62-21-8261-5809
www.tungaloy.com/id



tungaloy.com

follow us at:

facebook.com/tungaloyjapan

twitter.com/tungaloyjapan

www.youtube.com/tungaloycorporation

Distributed by:



FIND US ON THE CLOUD!
machingcloud.com



AS9100 Certified
78006
2015.11.04
ISO14001 Certified
EC97J1123
1997.11.26

Produced from Recycled paper

Dec. 2021 (TJ)