



Grooving and parting-off tool

TUNG^{HORT}**CUT**

Tungaloy Report No. 391S8-G

New TungCut internal grooving inserts for $DMIN = 12 \text{ mm}$



New double-ended small-size internal grooving inserts with exceptional features

■ Robust toolholder design

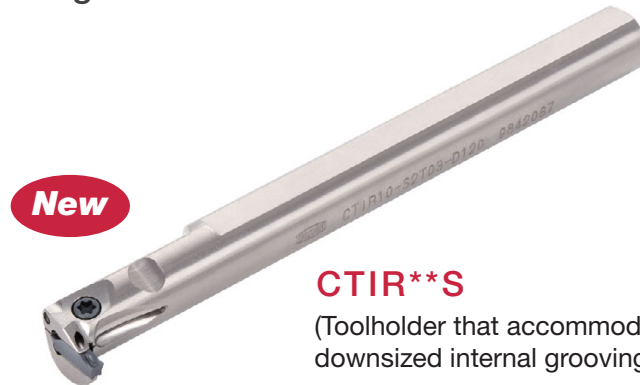

CTIR**S

(Toolholder that accommodates downsized internal grooving insert)

1 Improved chatter resistance

- Optimized screw location enhances insert clamping capability
- Shorter slot length

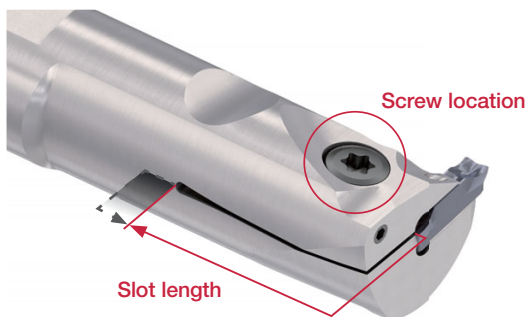

2 Effective chip evacuation

- Larger pockets promote smooth chip evacuation

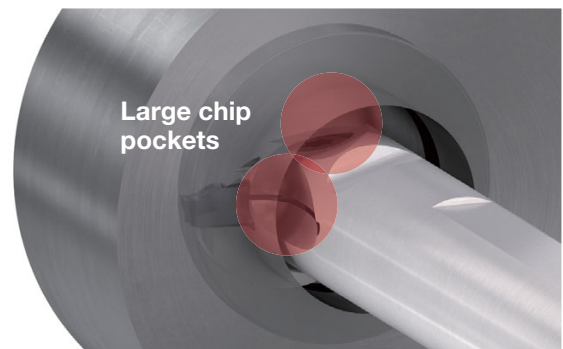

3 Internal coolant system

- Precision coolant delivered from the top to the cutting point for best performance and smooth chip evacuation.



CHIPBREAKER GUIDE

Internal grooving and parting

DGS*S type
(2 corners)



Lower cutting force and superior sharpness

Uniquely designed edge and chipbreaker
CW = 2 - 3 mm

Standard feed

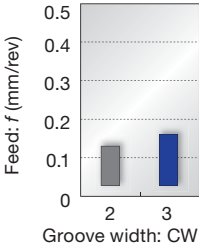

Feed: f (mm/rev)

Groove width: CW (mm)

Profiling and undercutting

DTR*S type
(2 corners)



Full radius type

Provides effective chip control during profile turning application
Molded inserts available
CW = 2 - 3 mm

Standard feed and DoC

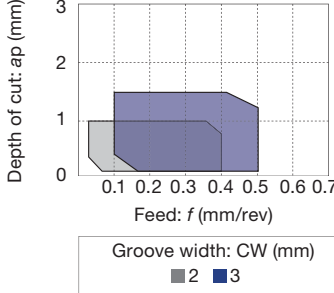

Depth of cut: a_p (mm)

Feed: f (mm/rev)

Groove width: CW (mm)

■ 2 ■ 3

General internal grooving

Internal grooving holder

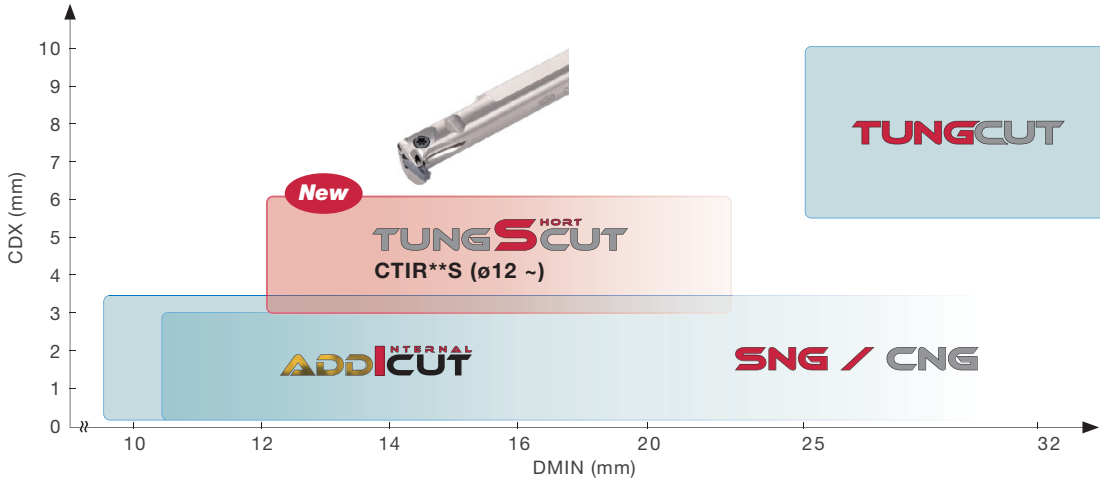

BoreMeister head

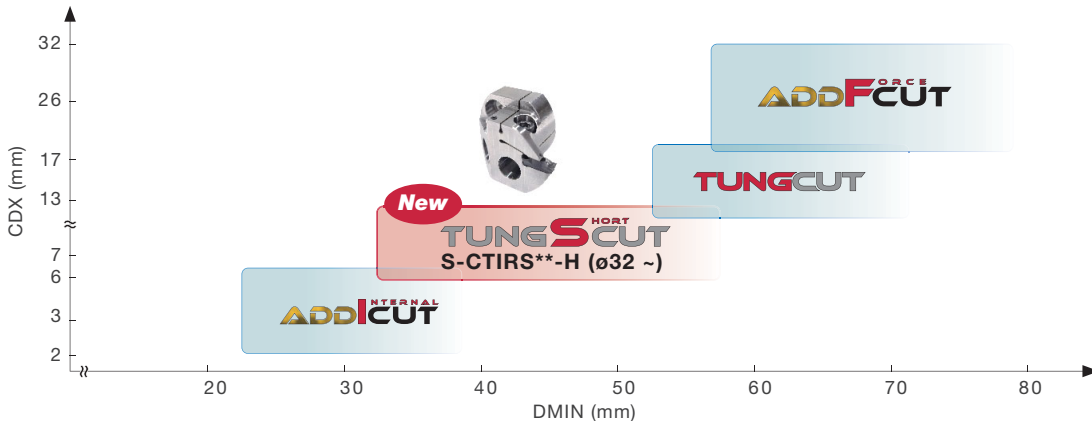

TOOLHOLDER

CTIR**S

Internal grooving and turning toolholder

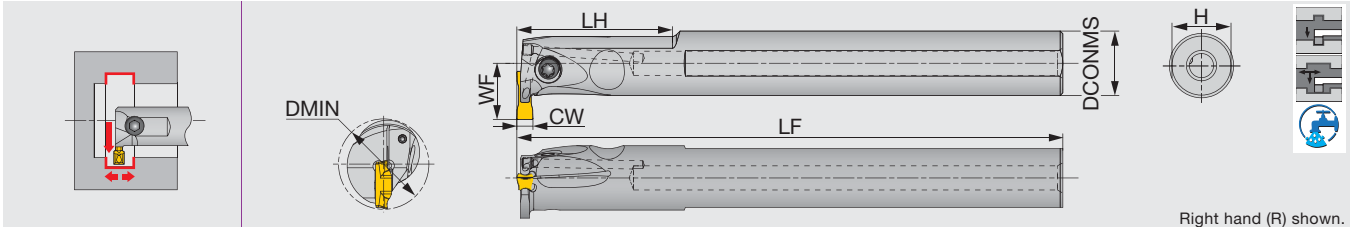

Designation	CW	DMIN	Seat size	CDX	DCONMS	H	LF ⁽¹⁾	LH	WF	Insert	Torque*
CTIR10S2T03-D120	2	12	S2	3	10	9	100	22	8.4	D**2S...	1.3
CTIR12S2T04-D160	2	16	S2	4	12	11	100	28	10.5	D**2S...	2.3
CTIR16S2T06-D200	2	20	S2	6	16	15	110	36	14.5	D**2S...	3.5
CTIR12S3T04-D160	3	16	S3	4	12	11	100	28	10.5	D**3S...	2.3
CTIR16S3T06-D200	3	20	S3	6	16	15	110	36	14.5	D**3S...	3.5

(1) LF is calculated with the groove width CW in the above table.
*Torque: Recommended clamping torque (N·m)

SPARE PARTS

Designation	Clamping screw	Wrench
CTIR10S2T03-D120	CSTB-2.5L080	T-8F
CTIR12S2T04-D160	CSTB-3.5D	T-9F
CTIR16S2T06-D200	CSTB-4	T-15F

MODULAR HEAD

S-CTIRS-H

BOREMEISTER

Exchangeable boring head, for internal grooving

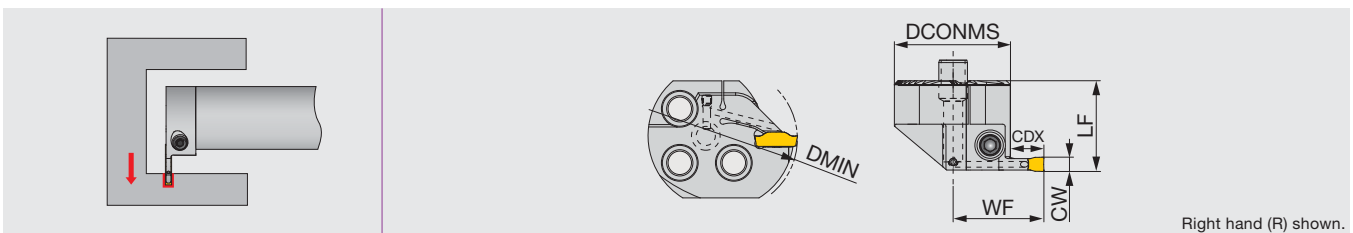

Designation	CW	CDX	DMIN	DCONMS	Seat size	LF ⁽¹⁾	WF	Shank	Insert
S25-CTIRS2T06D320-H	2	6	32	25	S2	19	19	D25	D**2S...
S32-CTIRS2T07D400-H	2	7	40	32	S2	23	23.5	D32	D**2S...
S25-CTIRS3T06D320-H	3	6	32	25	S3	19	19	D25	D**3S...
S32-CTIRS3T07D400-H	3	7	40	32	S3	23	23.5	D32	D**3S...

(1) The LF value is true when the insert with the same CW as indicated in the matching line is mounted in the pocket.

SPARE PARTS

Designation	Clamping screw	Wrench
S25-CTIRS*T06D320-H	CM3X0.5X6	P-2.5
S32-CTIRS*T07D400-H	CM5X0.5X8	P-4

Straight Shank

BOREMEISTER

Anti-vibration bars with through coolant for interchangeable turning heads

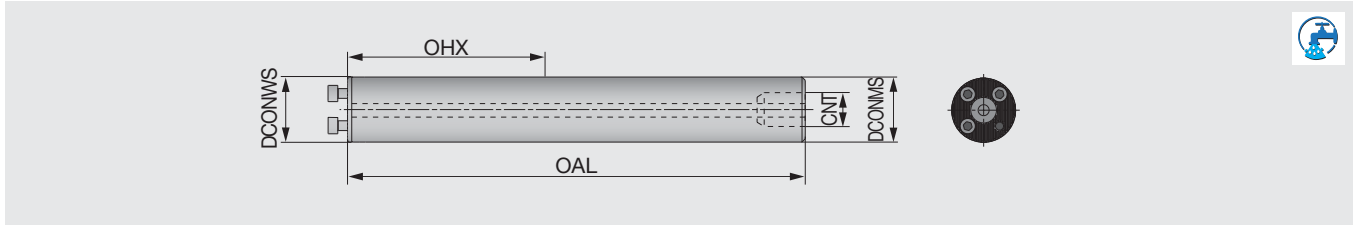

Designation	Material	DCONWS	DCONMS	OAL	OHX	CNT
D25-L255-7D-C	Steel	25	25	257.5	155	G1/4
D25-L330-10D-C	Steel	25	25	332.5	230	G1/4
D32-L320-7D-C	Steel	32	32	323	192	G3/8
D32-L416-10D-C	Steel	32	32	419	288	G3/8

SPARE PARTS



Designation	Clamping screw	Wrench
D25-L...	SRM4X12DIN912	HW3.0
D32-L...	SRM5X12DIN912	HW4.0

D#4D-SH

BOREMEISTER

Steel shank for internal turning, with through coolant

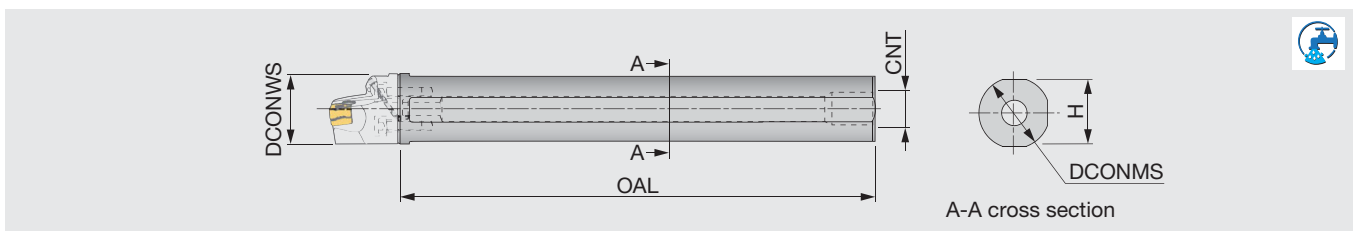

Designation	Material	DCONWS	DCONMS	OAL	CNT	H
D25-L200-4D-SH	Steel	25	25	200	UNF-2B 1/2"-20	23
D32-L218-4D-SH	Steel	32	32	218	UNF-2B 1/2"-20	29

SPARE PARTS



Designation	Clamping screw	Wrench
D25-L..., D25**4D-SH	SRM4X12DIN912	HW3.0
D32-L..., D32**4D-SH	SRM5X12DIN912	HW4.0

INSERT

DGS*S

Internal grooving and parting, 2 corners

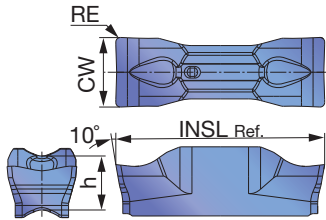

Designation	Seat size	CW±0.05	RE	Coated								INSL	h
				AH7025									
DGS2S-010	S2	2	0.1	●								9	2.2
DGS3S-020	S3	3	0.2	●								9	2.2

● : New

DTR*S

Profiling and undercutting

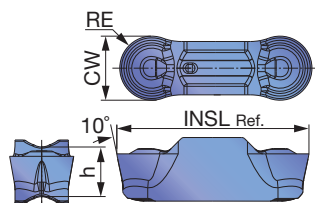

Designation	Seat size	CW±0.05	RE	Coated								INSL	h
				AH7025									
DTR2S-100	S2	2	1	●								9	2.2
DTR3S-150	S3	3	1.5	●								9	2.2

● : New

STANDARD CUTTING CONDITIONS

ISO	Workpiece material	Hardness	Grade	Cutting speed Vc (m/min)
P	Steel S45C, SCM435, etc. C45, 34CrMo4, etc.	< 300 HB	AH7025	50 - 180
M	Stainless steel SUS303, SUS304, etc. X10CrNiS18-9, X5CrNi18-9, etc.	< 200 HB	AH7025	50 - 120
K	Grey cast iron FC250, etc. 250, etc.	-	AH7025	50 - 180
	Ductile cast iron FCD450, etc. 450-10S, etc.	-	AH7025	50 - 120
S	Superalloys Inconel718, etc.	< HRC 40	AH7025	20 - 60
	Titanium alloys Ti-6Al-4V, etc.	< HRC 40	AH7025	20 - 80

PRACTICAL EXAMPLES

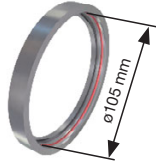
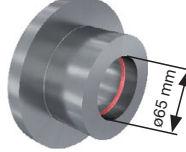
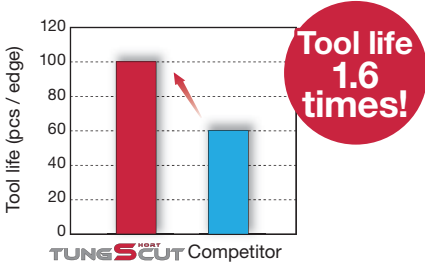
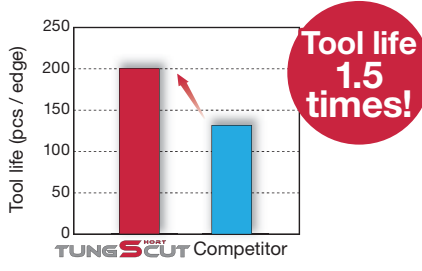
Workpiece type		Ring	Flywheel
Toolholder		CTIR16S2T06-D200	CTIR16S2T06-D200
Insert		DGS2S-010	DGS2S-010
Grade		AH7025	AH7025
Workpiece material		SCM415	SCr420
		 P	 P
Cutting conditions	Cutting speed : Vc (m/min)	100	100
	Feed : f (mm/rev)	0.15	0.2
	Groove width : CW (mm)	3	2
	Machining	Internal grooving	Internal grooving
	Coolant	Wet	Wet
Results		 <p>TungShortCut improved chip control and eliminated built-up edge, successfully achieving 1.6x tool life.</p>	 <p>TungShortCut provided superior chip evacuation, eliminating chip jamming. As a result, 1.5x tool life.</p>

Tungaloy Corporation (Head office)

11-1 Yoshima-Kogyodanchi
Iwaki-city, Fukushima 970-1144 Japan
Phone: +81-246-36-8501
Fax: +81-246-36-8542
www.tungaloy.co.jp

Tungaloy-NTK America Inc.

3726 N Ventura Drive
Arlington Heights, IL 60004, U.S.A.
Phone: +1-888-554-8394
Fax: +1-888-554-8392
www.tungaloy.com/us

Tungaloy Canada

432 Elgin St. Unit 3
Brantford, Ontario N3S 7P7, Canada
Phone: +1-519-758-5779
Fax: +1-519-758-5791
www.tungaloy.com/ca

Tungaloy de Mexico S.A.

C. Los Arellano 113,
Parque Industrial Siglo XXI
Aguascalientes, AGS, Mexico 20290
Phone: +52-449-929-5410
Fax: +52-449-929-5411
www.tungaloy.com/mx

Tungaloy-NTK do Brasil Ltda.

Avd. Independencia N4158 Residencial Flora
13280-000 Vinhedo, São Paulo, Brasil
Phone: +55-19-38262757
Fax: +55-19-38262757
www.tungaloy.com/br

Tungaloy-NTK Germany GmbH.

Katzbergstr. 3a
D-40764 Langenfeld, Germany
Phone: +49-2173-90420-0
Fax: +49-2173-90420-19
www.tungaloy.com/de

Tungaloy France S.A.S.

Les Fjords
19 avenue de Norvège
91140 Villebon Sur Yvette, France
Phone: +33-1-6486-4300
Fax: +33-1-6907-7817
www.tungaloy.com/fr

Tungaloy Italia S.r.l.

Via E. Andolfato 10
I-20126 Milano, Italy
Phone: +39-02-252012-1
Fax: +39-02-252012-65
www.tungaloy.com/it

Tungaloy Czech s.r.o.

Turanka 115
CZ-627 00 Brno, Czech Republic
Phone: +420-532 123 391
Fax: +420-532 123 392
www.tungaloy.com/cz

Tungaloy Ibérica S.L.

C/Miquel Servet, 43B, Nau 7
Pol. Ind. Bufalvent
ES-08243 Manresa (BCN), Spain
Phone: +34 93 113 1360
Fax: +34 93 876 2798
www.tungaloy.com/es

Tungaloy Scandinavia AB

Bultgatan 38
442 40 Kungälv, Sweden
Phone: +46-462119200
Fax: +46-462119207
www.tungaloy.com/se

Tungaloy Rus, LLC

Andropova avenue, h.18/7,
11 floor, office 3, 115432,
Moscow, Russia
Phone: +7-499-683-01-80
Fax: +7-499-683-01-81
www.tungaloy.com/ru

Tungaloy Polska Sp. z o.o.

Ul. Irysowa 1, 55-040 Bielany
Wroclawskie, Poland
Phone: +48 607 907 237
www.tungaloy.com/pl

Tungaloy-NTK UK Ltd.

Gallan Park, Watling Street,
Cannock, WS110XG, UK
Phone: +44 121 4000 231
Fax: +44 121 270 9694
www.tungaloy.com/uk

Tungaloy Hungary Kft

Erzsébet királyné útja 125
H-1142 Budapest, Hungary
Phone: +36 1 781-6846
Fax: +36 1 781-6866
www.tungaloy.com/hu

Tungaloy Turkey

Serifali Mah.bayraktar Bulvari Kule Sk. No:26
34775 Umraniye / Istanbul / Turkey
Phone: +90 216 540 04 67
Fax: +90 216 540 04 87
www.tungaloy.com/tr

Tungaloy Benelux b.v.

Tjalk 70
NL-2411 NZ Bodegraven, Netherlands
Phone: +31 172 630 420
Fax: +31 172 630 429
www.tungaloy.com/nl

Tungaloy Croatia

Ulica bana Josipa Jelačića 87,
10430, Samobor, Croatia
Phone: +385 1 3326 604
Fax: +385 1 3327 683
www.tungaloy.com/hr

Tungaloy Cutting Tool (Shanghai) Co.,Ltd.

Rm No 401 No.88 Zhabei
Jiangchang No.3 Rd
Shanghai 200436, China
Phone: +86-21-3632-1880
Fax: +86-21-3621-1918
www.tungaloy.com/cn

Tungaloy Cutting Tools (Taiwan) Co.,Ltd.

9F, No.293, Zhongyang Rd,
Xinzhuan Dist, New Taipei City,
24251 Taiwan
Phone: +886-2-8521-9986
Fax: +886-2-8521-8935
www.tungaloy.com/tw

Tungaloy Cutting Tools (Thailand) Co.,Ltd.

Interlink tower 4th Fl.
1858/5-7 Bangna-Trad Road
km.5 Bangna, Bangna, Bangkok 10260
Thailand
Phone: +66-2-751-5711
Fax: +66-2-751-5715
www.tungaloy.com/th

Tungaloy Singapore (Pte.), Ltd.

62 Ubi Road 1, #06-11 Oxley BizHub 2
Singapore 408734
Phone: +65-6391-1833
Fax: +65-6299-4557
www.tungaloy.com/sg

Tungaloy Vietnam

LE04.38, Lexington Residence
67 Mai Chi Tho St., Dist. 2,
Ho Chi Minh City, Vietnam
Phone: +84-2837406660
www.tungaloy.com/sg

Tungaloy India Pvt. Ltd.

One International Center,
Unit # 902-A, 9th Floor,
Tower 1, Senapati Bapat Marg,
Elphinstone Road (West),
Mumbai 400013, India
Phone: +91-22-6124-8803
Fax: +91-22-6124-8899
www.tungaloy.com/in

Tungaloy Korea Co., Ltd

#1312, Byucksan Digital Valley 5-cha
Beotkkot-ro 244, Geumcheon-gu
153-788 Seoul, Korea
Phone: +82-2-2621-6161
Fax: +82-2-6393-8952
www.tungaloy.com/kr

Tungaloy Malaysia Sdn Bhd

50 K-2, Kelana Mall, Jalan SS6/14
Kelana Jaya, 47301
Petaling Jaya, Selangor Darul Ehsan
Malaysia
Phone: +603-7805-3222
Fax: +603-7804-8563
www.tungaloy.com/my

Tungaloy Australia Pty Ltd

Unit 68 1470 Ferntree Gully Road
Knoxfield 3180 Victoria, Australia
Phone: +61-3-9755-8147
Fax: +61-3-9755-6070
www.tungaloy.com/au

PT. Tungaloy Indonesia

Kompleks Grand Wisata Block AA-10 No.3-5
Cibitung
Bekasi 17510, Indonesia
Phone: +62-21-8261-5808
Fax: +62-21-8261-5809
www.tungaloy.com/id



tungaloy.com

follow us at:

facebook.com/tungaloyjapan

twitter.com/tungaloyjapan

www.youtube.com/tungaloycorporation

Distributed by:



Tungaloy APP & SNS

FIND US ON THE CLOUD!
machingcloud.com



AS9100 Certified
78006
2015.11.04
ISO 14001 Certified
EC97J1123
1997.11.26