

液压刀柄 (T 系列)



T 系列高精度液压夹头刀柄 - 支持多种机床接口

■ 特点

• 操作简便, 精度高

只需用内六角扳手将执行螺丝拧到底, 即可实现高精度夹紧, 跳动精度 $\leq 0.003 \text{ mm}$ 。

• 加紧扭矩大, 防拔出安全性高, 确保加工稳定性

• 坚固的刀柄主体设计

高径向刚性防止加工过程中刀具侧向偏转, 从而提供更好的零件几何精度

• 出色的减振性能

独特的液压系统吸收振动, 确保无颤振加工和出色的工件表面质量, 同时避免刀具崩刃。



T 系列液压系统

① 执行器螺钉

无需扭矩扳手即可操作, 并配有独特的安全止动装置, 防止在切削工具未就位时因过度拧紧而损坏。

② 执行器活塞

将液压油压缩进入腔体系统。

③ 夹紧套筒和腔体系统

夹紧套筒向工具柄部膨胀。此夹紧过程首先将工具柄部居中, 然后在整个表面上完全夹紧

④ 刀柄主体

提供 HSK、SK、CAT 和 BT 机床接口

⑤ 长度调节螺丝

用于快速便捷的预设置。

⑥ 沟槽

将油、油脂或润滑剂残留物排入沟槽中, 使表面保持干燥。

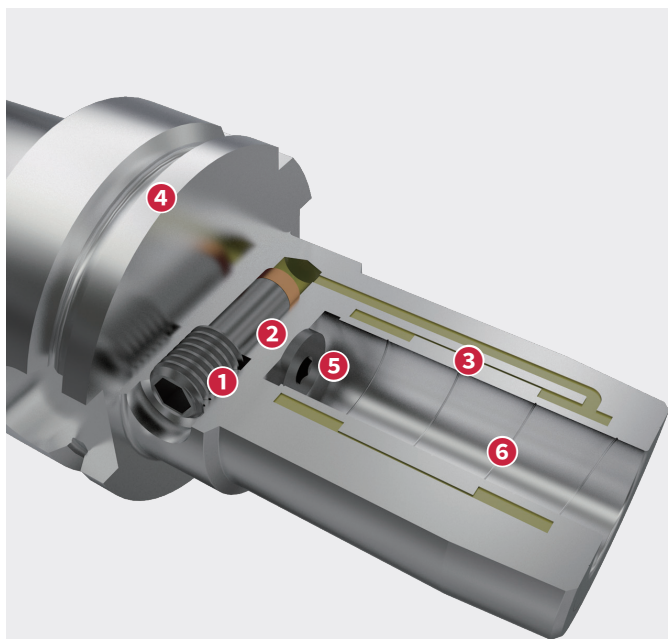

BT-HYDRO-T

BT MAS-403 ADB TungHydro 液压立铣刀夹头刀柄 (BT 类型)

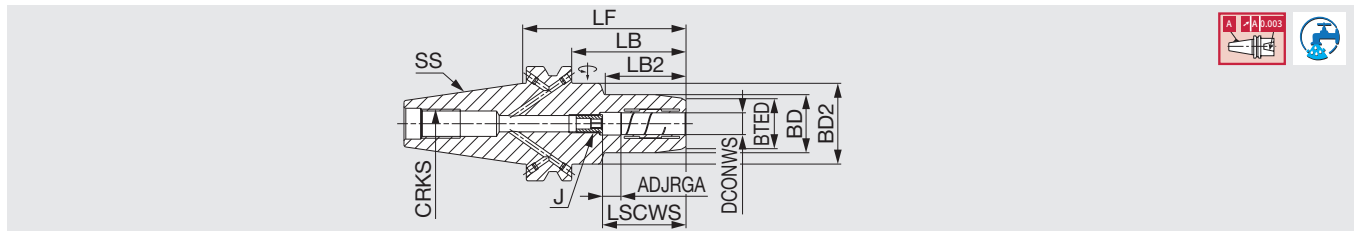

型号	SS	DCONWS	BD	BD2	BTED	LF	LSCWS	ADJ, RGA	LB2	LB	J	最小扭矩 (N m)	WT(kg)	CRKS	扳手*
BT30HYDRO6X55T	30	6	26	46	22.8	55	37	10	17.8		M5	16	0.6	M12	P-5
BT30HYDRO8X55T	30	8	28	46	24.8	55	37	10	18.4		M6	23	0.6	M12	P-5
BT30HYDRO10X55T	30	10	30	46	26.8	55	41	10	19		M8x1	45	0.6	M12	P-5
BT30HYDRO12X55T	30	12	32	46	28.8	55	46	10	19.5		M10x1	90	0.6	M12	P-5
BT30HYDRO16X90T	30	16	38	45	34.7	90	49	10	50	68	M12x1	185	0.9	M12	P-5
BT30HYDRO20X90T	30	20	42	45	37.7	90	51	10	50	68	M8x1	330	0.95	M12	P-5
BT40HYDRO6X90T	40	6	26	44.5	22	90	37	10	43	63	M5	16	1.4	M16	P-5
BT40HYDRO8X90T	40	8	28	44.5	24	90	37	10	44.5	63	M6	23	1.4	M16	P-5
BT40HYDRO10X90T	40	10	30	44.5	26	90	41	10	44.5	63	M8x1	45	1.4	M16	P-5
BT40HYDRO12X90T	40	12	32	44.5	28	90	46	10	44.5	63	M10x1	90	1.4	M16	P-5
BT40HYDRO16X90T	40	16	38	44.5	34	90	49	10	47.5	63	M12x1	185	1.5	M16	P-5
BT40HYDRO20X90T	40	20	42	44.5	38	90	51	10	47.5	63	M16x1	330	1.5	M16	P-5
BT40HYDRO32X100T	40	32	62	-	58.5	100	61	10	63	-	M16x1	650	2.55	M16	P-6
BT50HYDRO12X90T	50	12	32	49.25	28	90	46	10	31.5	52	M10x1	90	3.95	M24	P-5
BT50HYDRO20X90T	50	20	42	49.25	38	90	51	10	34	52	M16x1	330	3.95	M24	P-5
BT50HYDRO32X120T	50	32	64	70.25	60	120	61	10	62.5	82	M16x1	650	5.1	M24	P-6

*扳手不包含在内, 请单独订购。
工具柄部公差: h6
平衡等级: G2.5, 最高转速: 25,000 min-1

新

HSK A-HYDRO-T

TungHydro 液压立铣刀夹头刀柄 (HSK-A 型)

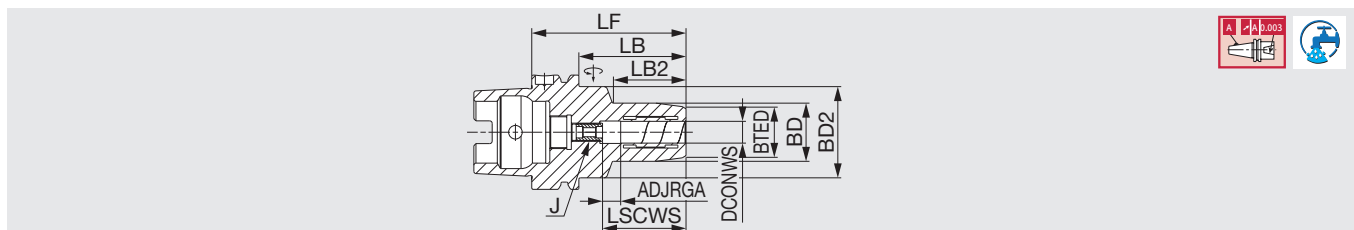

型号	DCONWS	BD	BD2	BTED	LF	LSCWS	ADJ, RGA	LB2	LB	J	最小扭矩 (N m)	WT(kg)	扳手*
HSKA63HYDRO6X70T	6	26	50	22	70	37	10	24	44	M5	16	1	P-5
HSKA63HYDRO8X70T	8	28	50	24	70	37	10	25	44	M6	23	1	P-5
HSKA63HYDRO10X80T	10	30	50	26	80	41	10	35	54	M8x1	45	1.1	P-5
HSKA63HYDRO12X85T	12	32	50	28	85	46	10	40	59	M10x1	90	1.1	P-5
HSKA63HYDRO16X90T	16	38	50	34	90	49	10	46	64	M12x1	185	1.2	P-5
HSKA63HYDRO20X90T	20	42	50	38	90	51	10	48	64	M16x1	330	1.3	P-5
HSKA63HYDRO25X120T	25	57	-	53	120	57	10	94	-	M16x1	400	2.16	P-6
HSKA63HYDRO32X125T	32	62	-	58	125	61	10	99	-	M16x1	650	2.7	P-6
HSKA100HYDRO10X90T	10	30	50	26	90	41	10	42	61	M8x1	45	2.5	P-5
HSKA100HYDRO12X95T	12	32	50	28	95	46	10	47	66	M10x1	90	2.6	P-5
HSKA100HYDRO16X100T	16	38	50	34	100	49	10	53	71	M12x1	185	2.7	P-5
HSKA100HYDRO20X105T	20	42	50	38	105	51	10	59	76	M16x1	330	2.8	P-5
HSKA100HYDRO25X110T	25	57	63	53	110	57	10	62	81	M16x1	400	3.7	P-6
HSKA100HYDRO32X110T	32	64	75	60	110	61	10	62	81	M16x1	650	3.8	P-6

*扳手不包含在内, 请单独订购。
请使用冷却管 (不包含在内)。
工具柄部公差: h6
平衡等级: G2.5, 最高转速: 25,000 min-1

COOLING TUBE-HSK

HSK 柄部冷却管

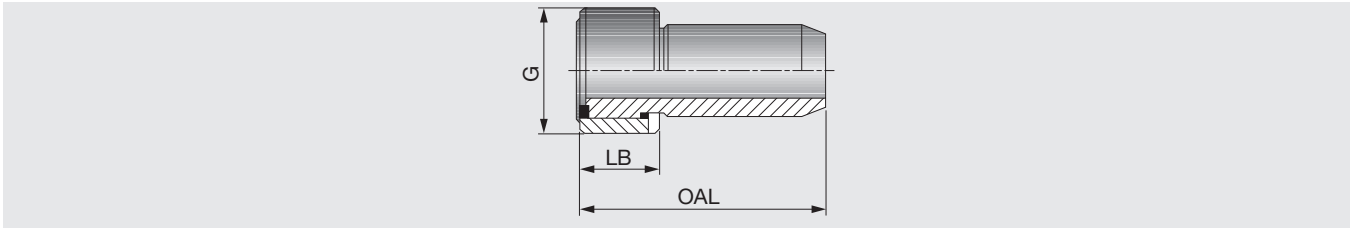

型号	HSK 尺寸	OAL	LB	G
COOLINGTUBEHKA63	63	36	11.5	M18X1
COOLINGTUBEHKA100	100	43.6	15.5	M24X1.5

扳手

HSK 冷却管用扳手

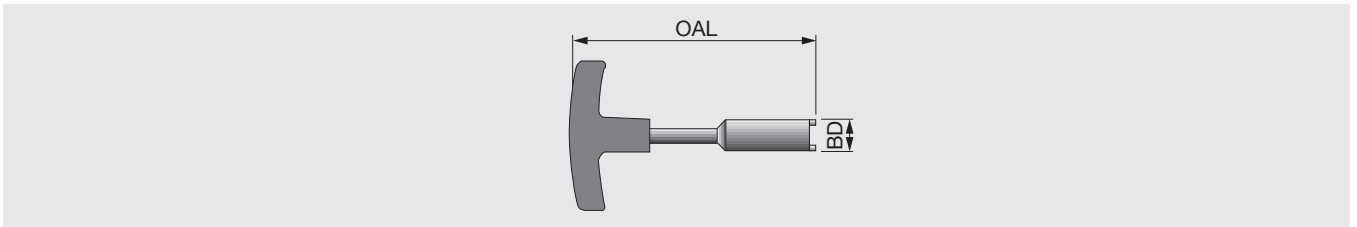

型号	HSK 尺寸	BD	OAL
WRENCH COOL TUBE HSK63	63	17	122
WRENCH COOL TUBE HSK100	100	22	141

SK-HYDRO-T

TungHydro 液压立铣刀夹头刀柄 (SK 型)

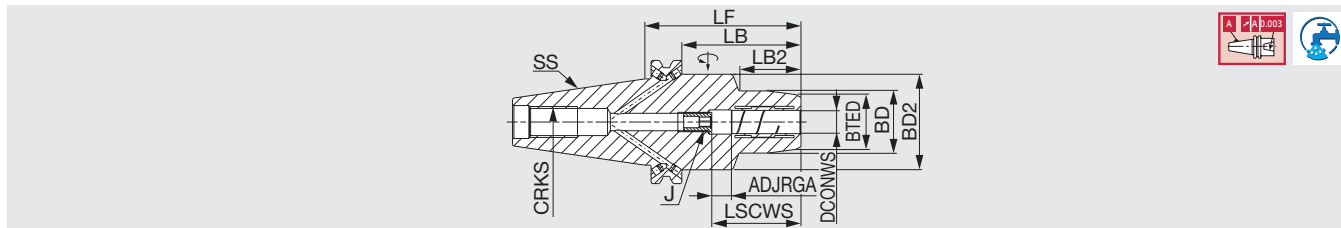

型号	SS	DCONWS	BD	BD2	BTED	LF	LSCWS	ADJRGA	LB2	LB	J	最小扭矩 (N m)	WT(kg)	CRKS	扳手*
SK40HYDRO6X80.5T	40	6	26	49.25	22	80.5	37	10	29.5	61.4	M5	16	1.4	M16	P-5
SK40HYDRO8X80.5T	40	8	28	49.25	24	80.5	37	10	30	61.4	M6	23	1.4	M16	P-5
SK40HYDRO10X80.5T	40	10	30	49.25	26	80.5	41	10	31	61.4	M8x1	45	1.4	M16	P-5
SK40HYDRO12X80.5T	40	12	32	49.25	28	80.5	46	10	31.5	61.4	M10x1	90	1.4	M16	P-5
SK40HYDRO16X80.5T	40	16	38	49.25	34	80.5	49	10	33	61.4	M12x1	185	1.4	M16	P-5
SK40HYDRO20X80.5T	40	20	42	49.25	38	80.5	51	10	34	61.4	M16x1	330	1.4	M16	P-5
SK40HYDRO25X80.5T	40	25	55	65.95	53	80.5	57	10	22	61.4	M16x1	400	1.8	M16	P-6
SK40HYDRO32X80.5T	40	32	63	72.95	60	80.5	61	10	25.5	61.4	M16x1	650	2	M16	P-6
SK50HYDRO12X80.5T	50	12	32	49.25	28	80.5	46	10	31.5	61.45	M10x1	90	3.2	M24	P-5
SK50HYDRO16X80.5T	50	16	38	49.25	34	80.5	49	10	33	61.45	M12x1	185	3.2	M24	P-5
SK50HYDRO20X80.5T	50	20	42	49.25	38	80.5	51	10	34	61.45	M16x1	330	3.3	M24	P-5
SK50HYDRO32X103.2T	50	32	64	70.25	60	103.2	61	10	62.5	81.15	M16x1	650	4.4	M24	P-6

*扳手不包含在内, 请单独订购。
工具柄部公差: h6
平衡等级: G2.5, 最高转速: 25,000 min-1

新

CAT-HYDRO-T

TungHydro 液压立铣刀夹头刀柄 (CAT 型)

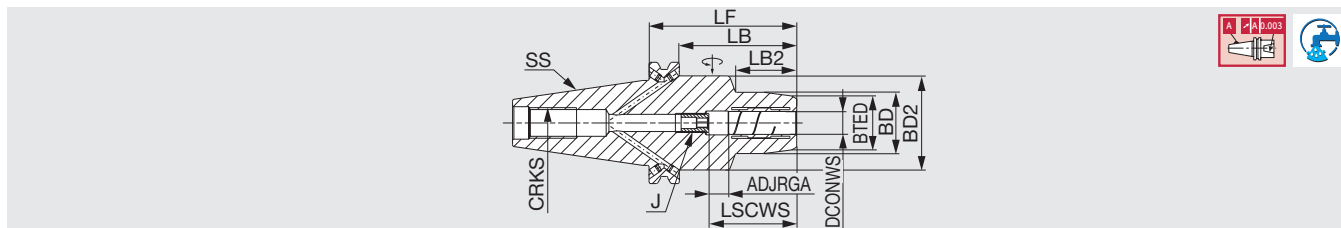

型号	SS	DCONWS	BD	BD2	BTED	LF	LSCWS	ADJRGA	LB2	LB	J	最小扭矩 (N m)	WT(kg)	CRKS	扳手*
CAT40HYDRO6X63.5T	40	6	26	44.45	19.8	63.5	37	10	25	44.45	M5	16	1.1	5/8-11	P-5
CAT40HYDRO8X63.5T	40	8	28	49	23.5	63.5	37	10	26	44.45	M5	23	1.1	5/8-11	P-5
CAT40HYDRO10X63.5T	40	10	30	49	24	63.5	41	10	28	44.45	M5	45	1.1	5/8-11	P-5
CAT40HYDRO12X63.5T	40	12	32	49	27.1	63.5	46	10	27	44.45	M10x1	90	1.1	5/8-11	P-5
CAT40HYDRO16X63.5T	40	16	38	49	33.1	63.5	49	10	28	44.45	M10x1	185	1.2	5/8-11	P-5
CAT40HYDRO20X63.5T	40	20	42	49	37.6	63.5	51	10	26	44.45	M10x1	330	1.2	5/8-11	P-5
CAT40HYDRO1/4X2.500T ⁽¹⁾	40	1/4"	26	44.45	19.8	63.5	37	10	25	44.45	M5	17	1.1	5/8-11	P-5
CAT40HYDRO3/8X2.500T ⁽¹⁾	40	3/8"	30	49	24	63.5	41	10	28	44.45	M5	45	1.1	5/8-11	P-5
CAT40HYDRO1/2X2.500T ⁽¹⁾	40	1/2"	32	49	27	63.5	46	10	24.5	44.45	M10x1	95	1.1	5/8-11	P-5
CAT40HYDRO5/8X2.500T ⁽¹⁾	40	5/8"	38	49	33.1	63.5	49	10	28	44.45	M10x1	185	1.2	5/8-11	P-5
CAT40HYDRO3/4X2.500T ⁽¹⁾	40	3/4"	44.5	49	38	63.5	51	10	23.17	44.45	M10x1	310	1.2	5/8-11	P-5
CAT50HYDRO12X81T	50	12	32	49	25.5	81	46	10	40	61.95	M10x1	90	3.1	1-8	P-5
CAT50HYDRO20X81T	50	20	42	51	35.5	81	51	10	46	61.95	M10x1	330	3.2	1-8	P-5
CAT50HYDRO25X81T	50	25	48	68	41.5	81	57	10	35.4	61.95	M10x1	400	3.5	1-8	P-6
CAT50HYDRO32X81T	50	32	62	75	55.8	81	61	10	40	61.95	M10x1	650	3.8	1-8	P-6
CAT50HYDRO1/2X3.189T ⁽¹⁾	50	1/2"	32	44.45	27.7	81	46	10	31.5	61.95	M10x1	95	3.1	1-8	P-5
CAT50HYDRO3/4X3.189T ⁽¹⁾	50	3/4"	44.5	49	38.9	81	51	10	43.17	61.95	M10x1	310	3.2	1-8	P-5
CAT50HYDRO1X3.189T ⁽¹⁾	50	1"	48	48	43.3	81	57	10	38.5	61.95	M10x1	400	3.4	1-8	P-6
CAT50HYDRO1-1/4X3.189T ⁽¹⁾	50	1 1/4"	62	75	55.8	81	61	10	40	61.95	M10x1	650	3.8	1-8	P-6

(1) 英寸
*扳手不包含在内, 请单独订购。
工具柄部公差: h6
平衡等级: G2.5, 最高转速: 25,000 min-1

总公司 泰珂洛超硬工具 (上海) 有限公司

ADD : 上海市静安区江场三路 88 号 401 室

TEL : 021-36321879 36321880

FAX : 021-36321918

广州分公司

ADD : 广州市番禺区沙湾镇福龙路 999 号

沙湾珠宝产业园钻汇大厦 807 室

TEL : 020-38395085 38395116

FAX : 020-38395106

成都办事处

ADD : 成都市高新区益州大道中段 722 号

复城国际广场 T4-1709A

TEL : 028-61500820

FAX : 028-61500821

天津分公司

ADD : 天津市河西区怒江道创智东园

2-1007 室

TEL : 022-83709199

FAX : 022-83709199

大连分公司

ADD : 大连经济技术开发区铁山中路 62 号

TEL : 0411-87963170

FAX : 0411-87963141

西安办事处

ADD : 陕西省西安市高新区锦业一路 56 号

研祥城市广场 B 座 2028 室

TEL : 029-81125898

FAX : 029-81125898



了解更多产品信息
请访问泰珂洛官方中文网站：
www.tungaloy.com/cn

查看产品视频请访问泰珂洛哔站视频网站



<https://space.bilibili.com/701520171>



微信官方公众号

FIND US ON THE CLOUD!
machiningcloud.com



AS9100 Certified
78006
2015.11.04
ISO14001 Certified
EC97J1123
1997.11.26

Produced from Recycled paper

Jan. 2025(TJ)