

**MODEL IN SCALE 1:10**

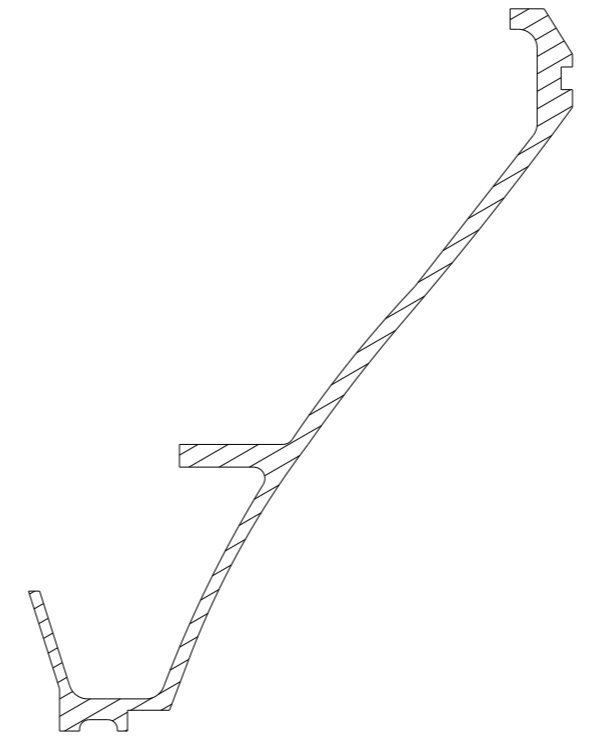

Section cut A-A  
Scale: 1:2

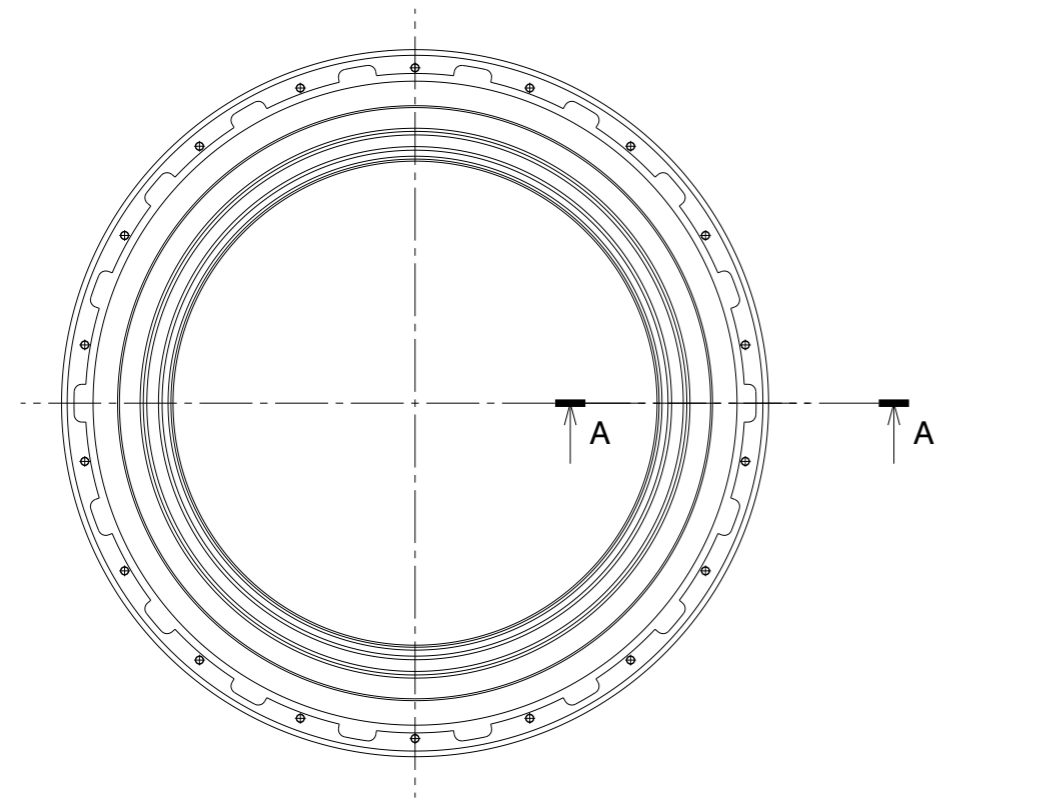
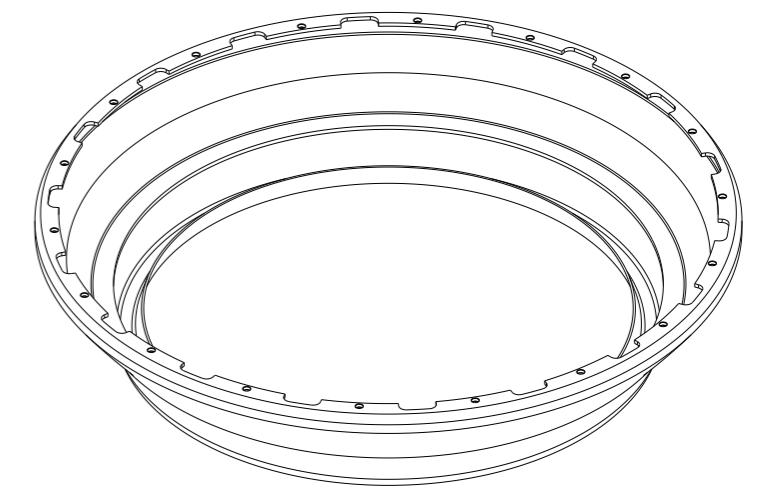

Isometric view  
Scale: 1:10

LATHE MACHINE : Vertical lathe  
M/C : 5 axis M/C

**CASING**

**WORKPIECE MATERIAL -Ti-6Al-4V**

Unspecified Tolerances	Draw		Customer: TUNGALOY	Japan	
	Design				
Dim.s: --	Check		Designation: <b>LAYOUT-CASING-61143</b>		Dwg.No. <b>32447993-HCL</b>
	Appr.		Process	Layout.	Page 1 Of 1
Angles: --	Scale	--	Lead Drawing		Rev. No.
			--		Reg.No.
© 2019 Tungaloy Corporation - Copyrights Notice			FL-40030658		<b>61143/1</b> <span style="border: 1px solid black; padding: 2px;">A3L</span>

MODEL IN SCALE 2:3 TOOLS IN SCALE 1:2

**CUT 101/102**  
OD Turning Rough  
 PCLNR2525M12-CHP  
 CNMG120412-HRM AH8015

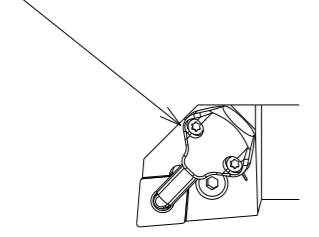

**TungTurn-Jet**  
**AH8000**

**CUT 101/102**  
OD Turning Rough  
 ACLNR2525X-12-CHP-MC  
 CNMG120412HRM AH8015

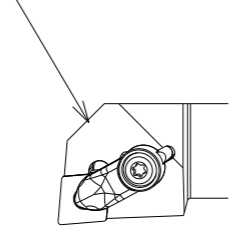

**TungTurn-Jet**  
**AH8000**

**CUT 101**  
OD Turning Rough  
 PPXOL2525M11-HF  
 POMG110612-MNW AH8015

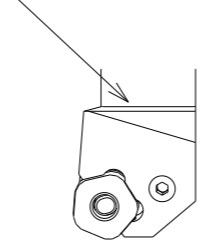

**TurnTenFeed**  
**AH8000**

**CUT 102**  
OD Turning Rough  
 PRGCR2525M12  
 RCMT1204M0-RS AH8015

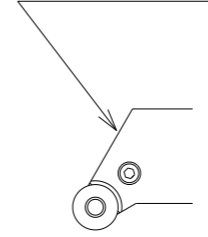

**TungTurn**  
**AH8000**

**CUT103**  
OD Grooving Rough  
 CHSR2525-CHP-MC  
 CAER-4T16-CHP  
 DGS4-030 AH7025

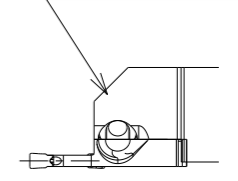

**TungCut**  
**TungTurn-Jet**  
**TungModularSystem**

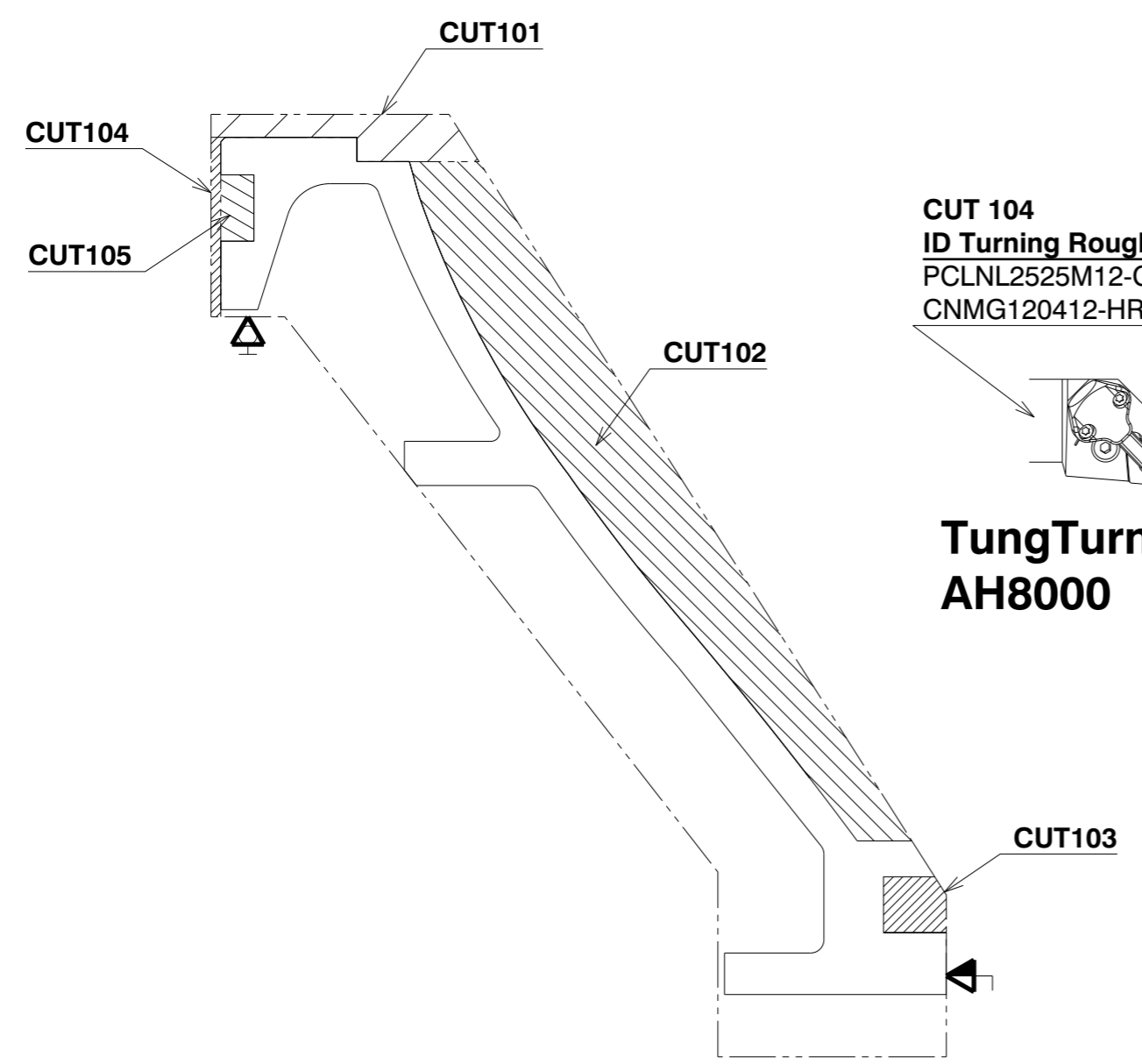

**CUT 104**  
ID Turning Rough  
 PCLNL2525M12-CHP  
 CNMG120412-HRM AH8015

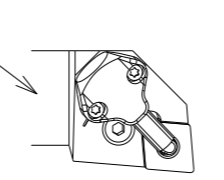

**TungTurn-Jet**  
**AH8000**

**CUT 104**  
ID Turning Rough  
 C6PCLNR45065-12-CHP  
 CNMG120412-HRM AH8015

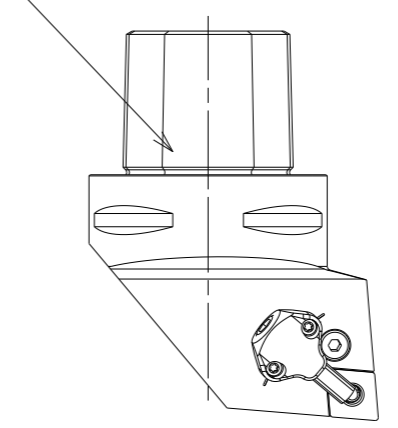

**TungCap**  
**TungTurn-Jet**  
**AH8000**

**CUT 105**  
ID Grooving Rough  
 CHSL2525-CHP-MC  
 CAEL-6T20-CHP  
 DGS6-030 AH7025

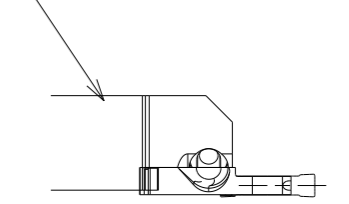

**TungCut**  
**TungTurn-Jet**  
**TungModularSystem**

**Lathe : O.D./I.D. Rough Turning**

Unspecified Tolerances	Draw		Customer: TUNGALOY	Japan	
	Design		Designation: LAYOUT OP100-CASING-61143		
Dim.s: -.-	Check		Process		Page 1
	Appr.		Concept		Rev. No. 1
Angles: -.-	Scale	-	Layout.		Reg.No. 61143/1
	© 2019 Tungaloy Corporation - Copyrights Notice		FL-40030658		A3L

MODEL IN SCALE 2:3 TOOLS IN SCALE 1:2

**CUT 201/202/203**  
**End Face Turning Rough**  
**ID Turning Rough**  
 C6PCLNR45065-12-CHP  
 CNMG120412-HRM AH8015

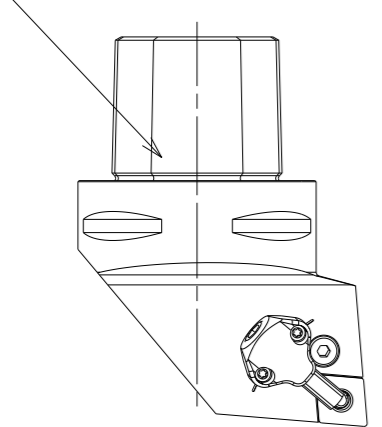

**TungCap**  
**TungTurn-Jet**  
**AH8000**

**CUT 201/202/203**  
**End Face Turning Rough**  
**ID Turning Rough**  
 PCLNL2525M12-CHP  
 CNMG120412-HRM AH8015

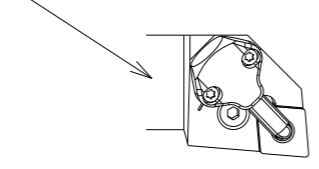

**TungTurn-Jet**  
**AH8000**

**CUT 204/205**  
**ID Turning Rough**  
 C6CHFVN33046-CHP  
 CAEL-6T20-CHP  
 DGS6-030 AH7025

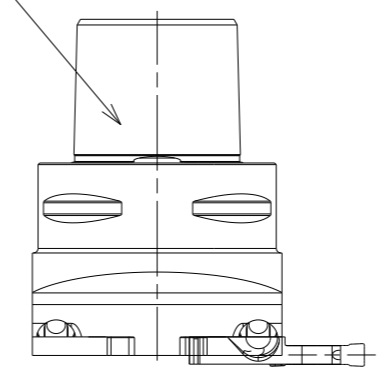

**TungCap**  
**TungCut**  
**TungTurn-Jet**  
**TungModularSystem**

**CUT 204/205**  
**ID Turning Rough**  
 CHSL2525-CHP-MC  
 CAEL-6T20-CHP  
 DGS6-030 AH7025

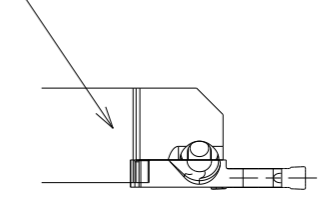

**TungCut**  
**TungTurn-Jet**  
**TungModularSystem**

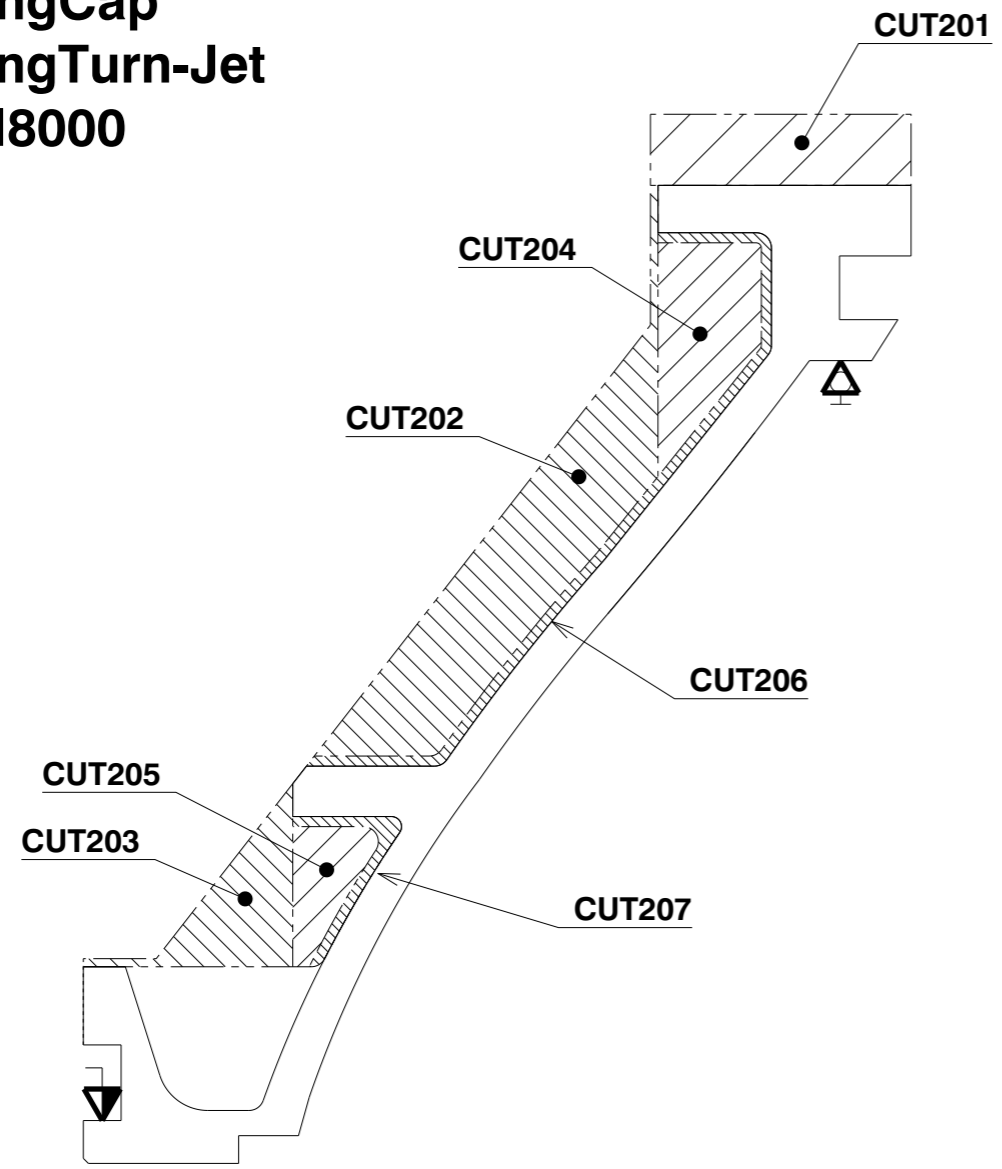

**CUT 206/207**  
**ID Turning Medium**  
 C6-JM-RF65L75-CHP (Special)  
 DTR4-200 AH905

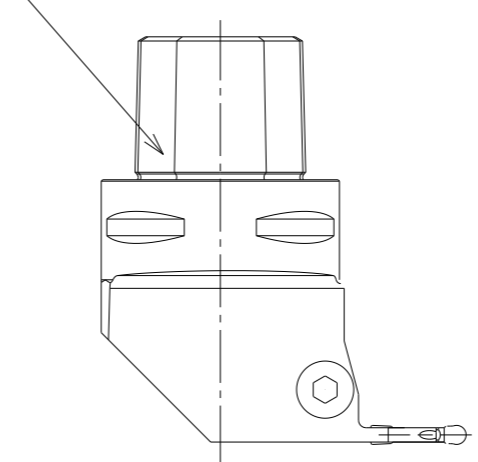

**TungCap**  
**TungCut**  
**TungTurn-Jet**  
**AH905**

**CUT 205/207**  
**ID Turning Medium**  
 CHSL2525-CHP-MC  
 CAEL-4T20-CHP  
 DTR4-200 AH905

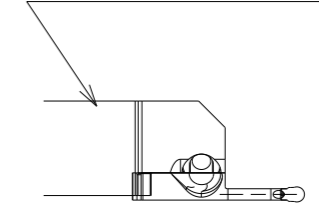

**TungCut**  
**TungTurn-Jet**  
**AH905**

**Lathe : I.D. Rough Turning**

Unspecified Tolerances	Draw		Customer: TUNGALOY	Japan	
	Design				
Dim.s:	Check		Designation:		Dwg.No. 32447993-HC1
	Appr.		LAYOUT OP200-CASING-61143		
Angles:	Scale		Process		Page 1 Rev.
			Concept		
			-		Of 1 No. 1
			FL-40030658		
					Reg.No. 61143/1
					A3L

© 2019 Tungaloy Corporation  
 Copyrights Notice



MODEL IN SCALE 2:3 TOOLS IN SCALE 1:2

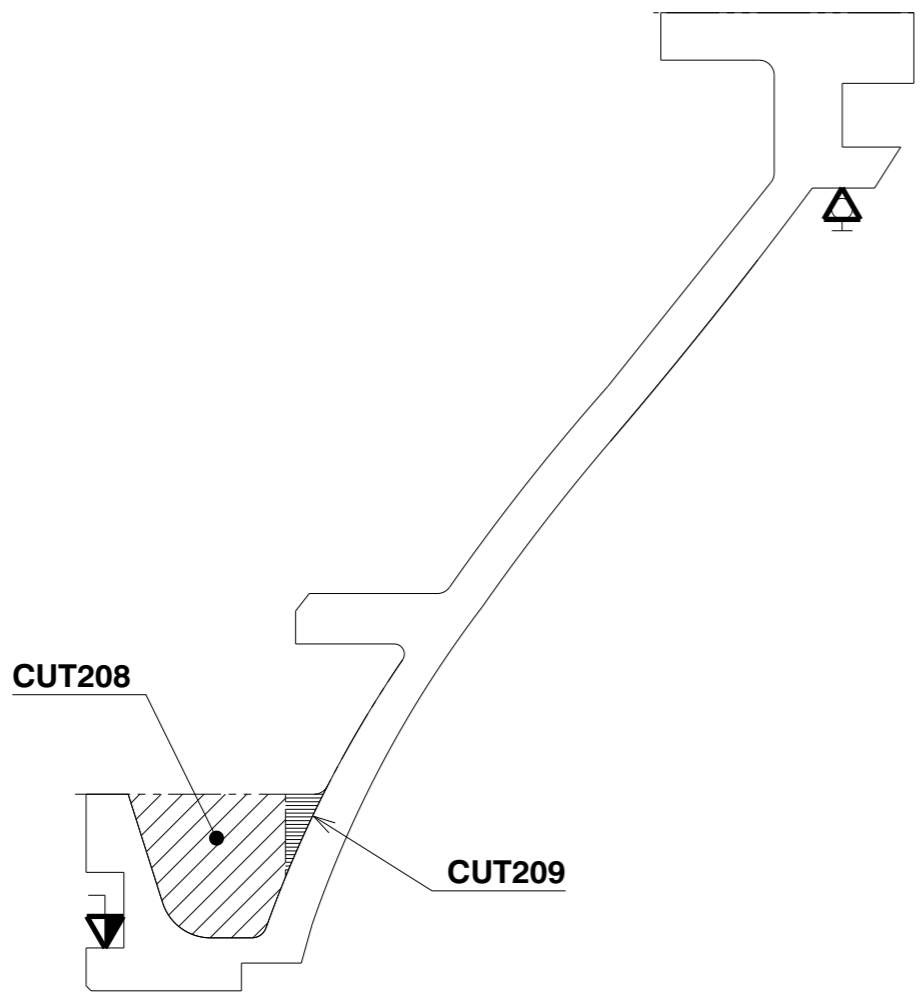

**CUT208**  
**ID Turning Rough**  
 JCM-W6R2525F30L170-CHP (Special)  
 DGS6-030 AH7025

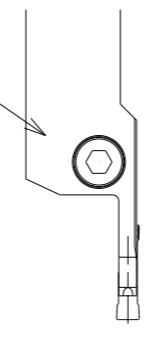

**TungCut**  
**TungTurn-Jet**

**CUT209**  
**ID Turning Rough**  
 JCM-W6R2525F40L170-CHP (Special)  
 DTR6-300 AH905

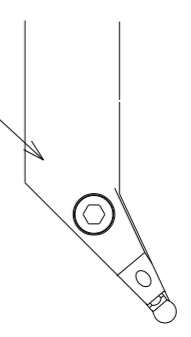

**TungCut**  
**TungTurn-Jet**  
**AH905**

**Holder with TungCap**  
 C6ASHA25-HPMC

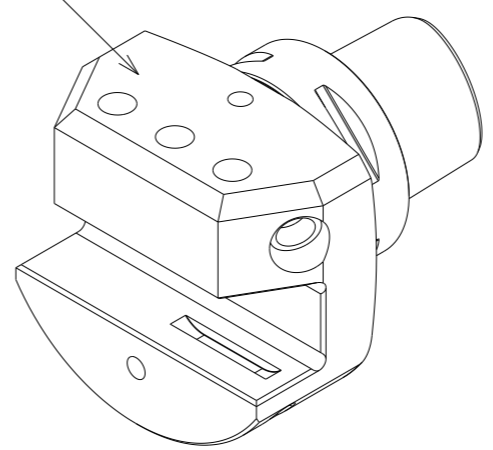

**TungCap**  
**TungTurn-Jet**

**Holder with TungCap**  
 C6ASHR251-J-HPMC

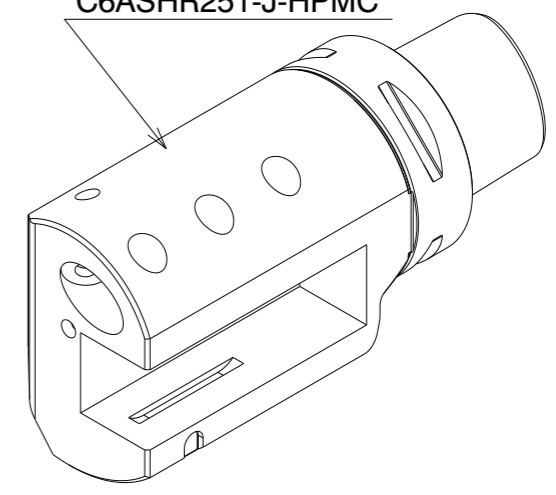

**TungCap**  
**TungTurn-Jet**

**Lathe : Face / I.D. Rough Turning**

Unspecified Tolerances	Draw		Customer: TUNGALOY	Japan	
Dim.s:	Design		Designation:		
-. -	Check		LAYOUT OP200-CASING-61143		Page 1
Angles:	Appr.		Process	Layout.	Of 1
-. -	Scale		Concept		Rev. No.
					Reg.No. 61143/1
					A3L

© 2019 Tungaloy Corporation  
 - Copyrights Notice



FL-40030658

MODEL IN SCALE 2:3 TOOLS IN SCALE 1:2

**CUT 301**  
**OD Turning Rough**  
 PCLNR2525M12-CHP  
 CNMG120412-HRM AH8015

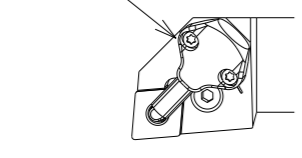

**TungTurn-Jet**  
**AH8000**

**CUT 302/303**  
**OD Turning Finish**  
 PDJNL2525M15-CHP  
 DNMG150408-HRF AH8015

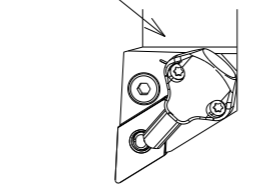

**TungTurn-Jet**  
**AH8000**

**CUT 302/303**  
**OD Turning Finish**  
 ADJNL2525X-15-CHP-MC  
 DNMG150608-HRF AH8015

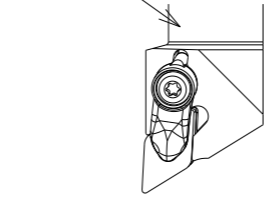

**TungTurn-Jet**  
**AH8000**

**CUT 304**  
**End Face Grooving Finish**  
 JCM-W5L2525F13L150-CHP (Special)  
 DTR5-250 AH905

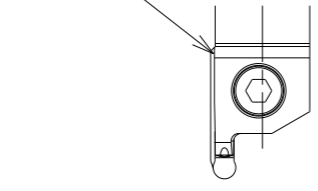

**TungCut**  
**TungTurn-Jet**  
**AH905**

**CUT 304**  
**End Face Grooving Finish**  
 CTFVR2525-5T20-140200  
 DTR5-250 AH905

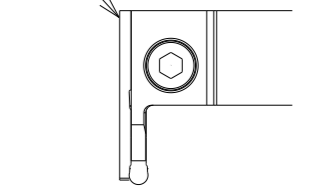

**TungCut**  
**TungTurn-Jet**  
**AH905**

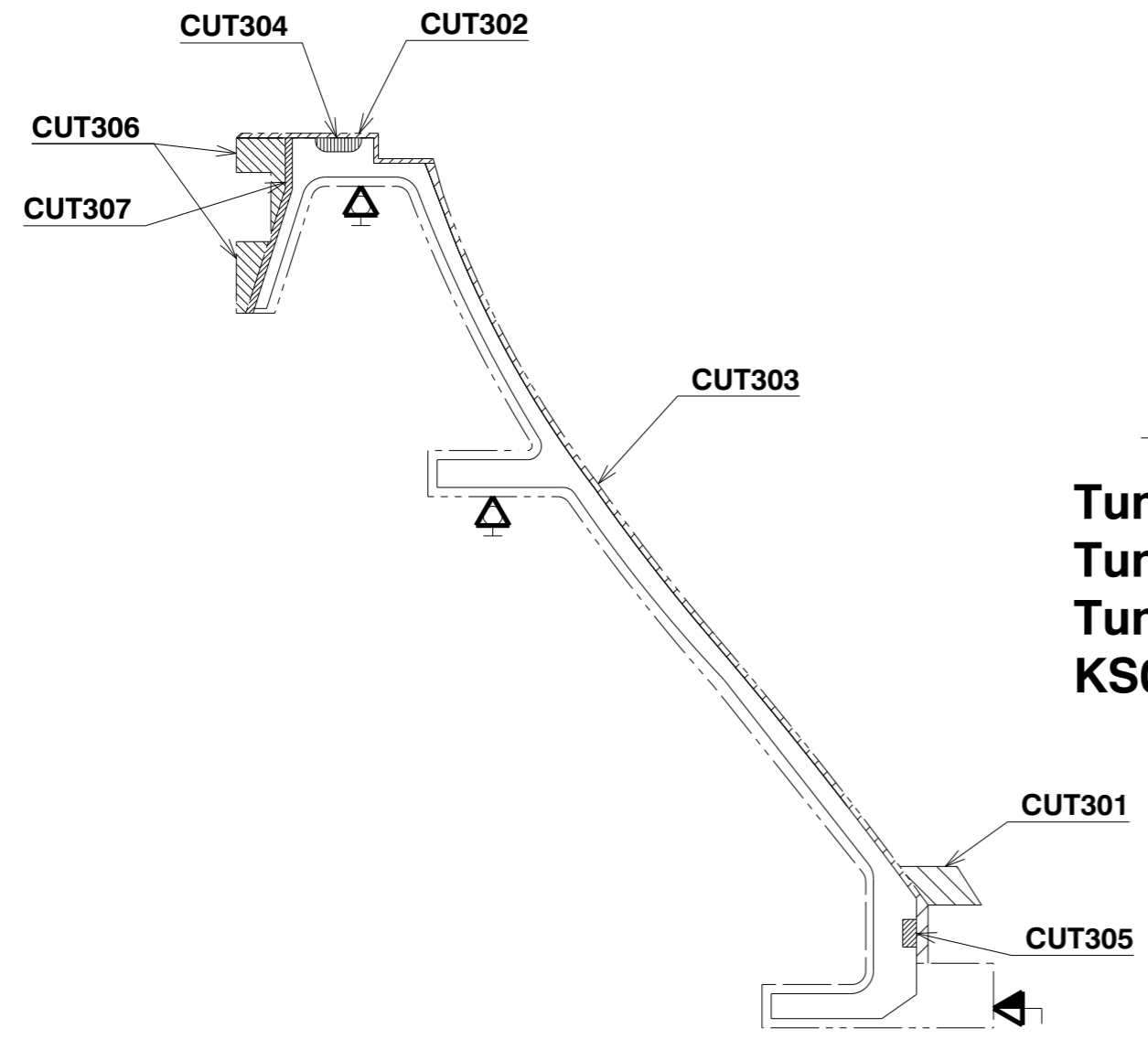

**CUT 305**  
**OD Grooving Finish**  
 CHSR2525-CHP-MC  
 CAER-4T16-CHP  
 DGG400-040 KS05F

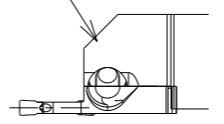

**TungCut**  
**TungTurn-Jet**  
**TungModularSystem**  
**KS05F**

**CUT 306**  
**ID Turning Rough**  
 PCLNL2525M12-CHP  
 CNMG120412-HRM AH8015

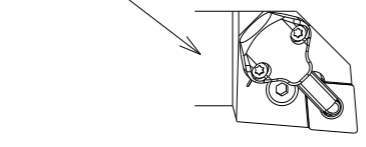

**TungTurn-Jet**  
**AH8000**

**CUT 307**  
**ID Turning Finish**  
 PDJNL2525M15-CHP  
 DNMG150408-HRF AH8015

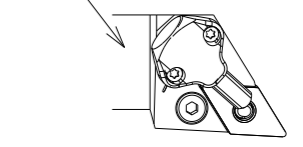

**TungTurn-Jet**  
**AH8000**

**Lathe : O.D. / I.D. Finish Turning**

Unspecified Tolerances	Draw		Customer: TUNGALOY	Japan	
Dim.s:	Design		Designation:		
Angles:	Check		LAYOUT OP300-CASING-61143		Page 1
	Appr.		Process	Layout.	Of 1
	Scale	-		Concept	Rev. No. 1
					Reg.No. 61143/1
					A3L

MODEL IN SCALE 2:3 TOOLS IN SCALE 1:2

**CUT 401**  
OD Turning Rough  
 PCLNR2525M12-CHP  
 CNMG120412-HRM AH8015

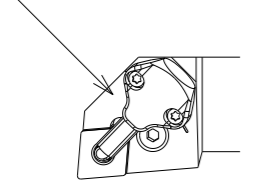

**TungTurn-Jet**  
**AH8000**

**CUT 402**  
Face Turning Finish  
 PDJNL2525M15-CHP  
 DNMG150408-HRF AH8015

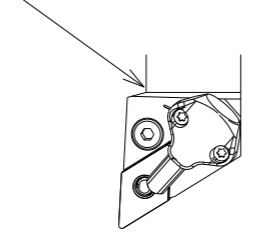

**TungTurn-Jet**  
**AH8000**

**CUT 403/405**  
ID Turning Finish  
 PDJNR2525M15-CHP  
 DNMG150408-HRF AH8015

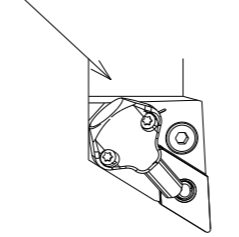

**TungTurn-Jet**  
**AH8000**

**CUT 404/406**  
ID Turning Finish  
 JCM-W4R2525F50L155-CHP (Special)  
 DTR4-200 AH905

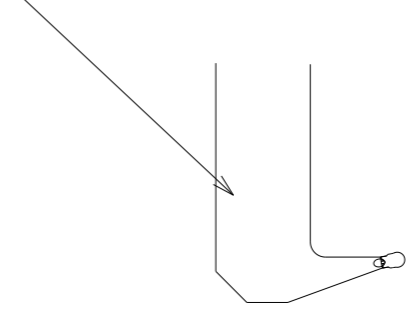

**TungCut**  
**TungTurn-Jet**  
**AH905**

**CUT 405**  
ID Turning Finish  
 JCM-W4R2525F50L150-CHP (Special)  
 DTR4-200 AH905

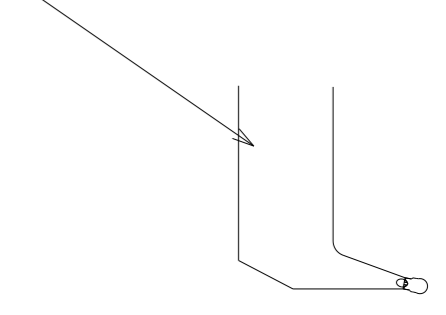

**TungCut**  
**TungTurn-Jet**  
**AH905**

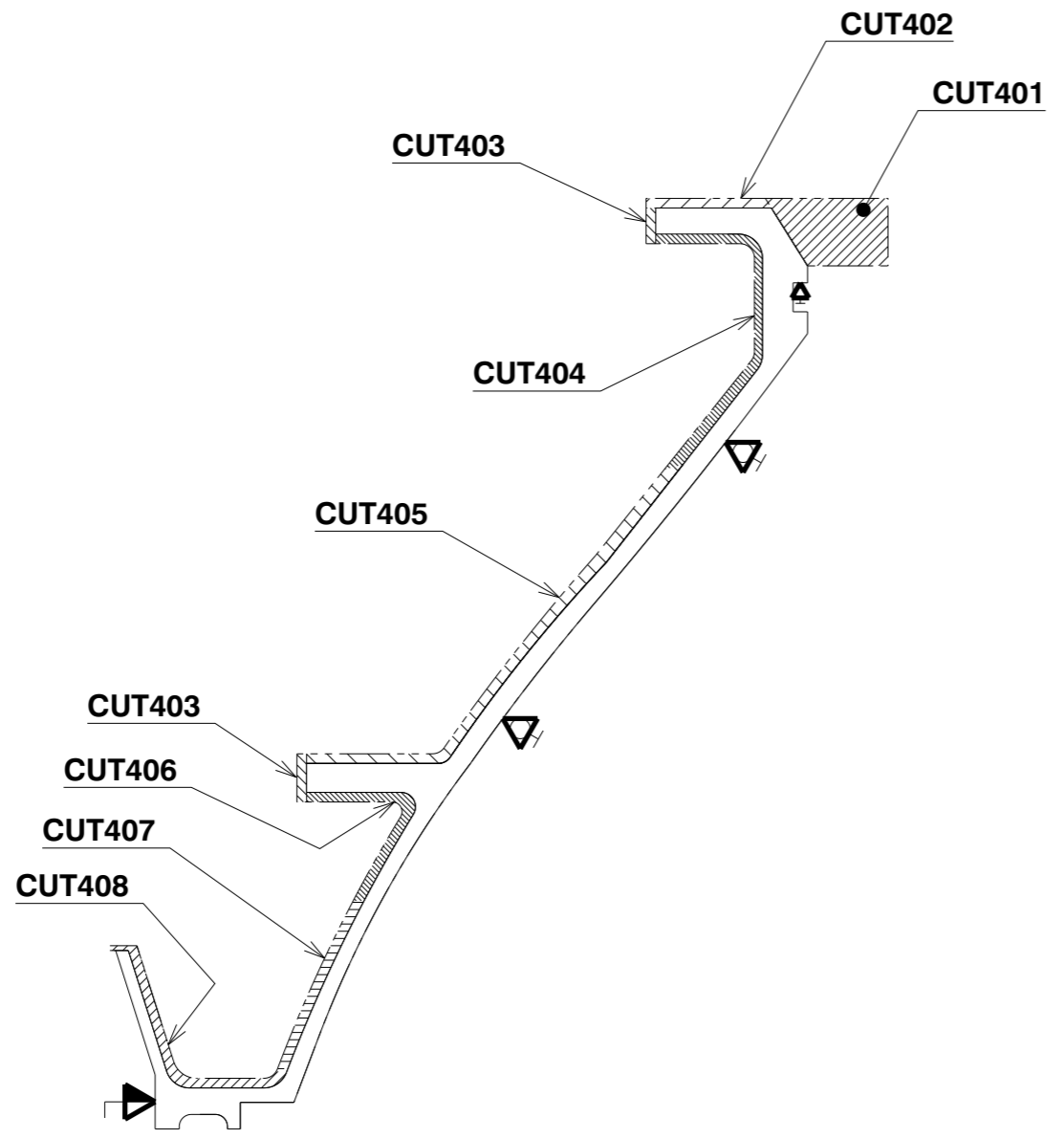

**CUT 407**  
ID Turning Finish  
 JCM-W5R2525F40L170-CHP (Special)  
 DTR5-250 AH905

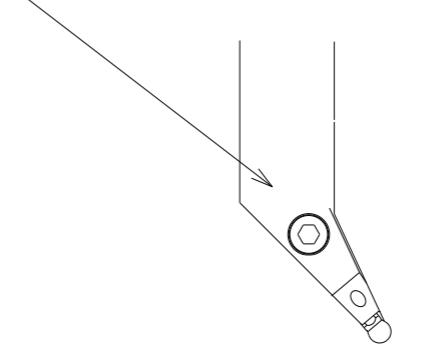

**TungCut**  
**TungTurn-Jet**  
**AH905**

**CUT 408**  
ID Turning Finish  
 JCM-W5R2525F30L170-CHP (Special)  
 DTR5-250 AH905

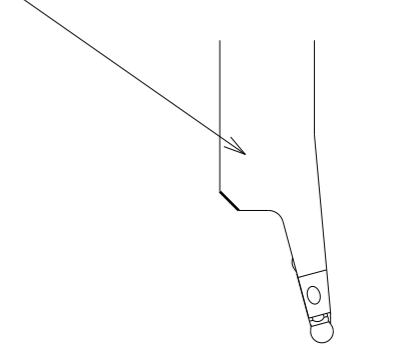

**TungCut**  
**TungTurn-Jet**  
**AH905**

**Lathe : O.D. / I.D. Finish Turning**

Unspecified Tolerances	Draw		Customer: TUNGALOY	Japan	
	Design				
Dim.s:	Check		Designation:		Dwg.No.
	Appr.		LAYOUT OP400-CASING-61143		32447993-HC4
Angles:	Scale		Process	Layout.	Page 1
			Concept		Of 1
					Rev. No. 1
					Reg.No. 61143/1
					A3L

© 2019 Tungaloy Corporation  
 Copyrights Notice



FL-40030658

MODEL IN SCALE 1:5 TOOLS IN SCALE 1:2

**CUT 501/502**  
**Shoulder Milling Rough/Finish**  
 EPAV06M016C16.0R04  
 AVGT060302PBER-MJ AH130

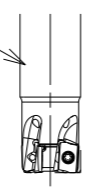

**TungForceRec**  
**AH130**

**CUT 502**  
**Shoulder Milling Finish**  
 TECK120H7-26C12CF-R06T83



**SolidMeister**  
**VariableMeister**

**CUT 503/504**  
**Chamfering Finish**  
 CHAMFERING CUTTER (Special)  
 SDMT050204PN-MJ AH725

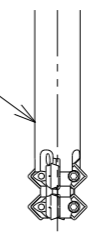

**TungQuad**

**CUT 503/504/506**  
**Chamfering Finish**  
 VSSD10L070S06-W-A  
 VCW118L05.0A45-02S06AH725

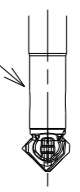

**TungMeister**

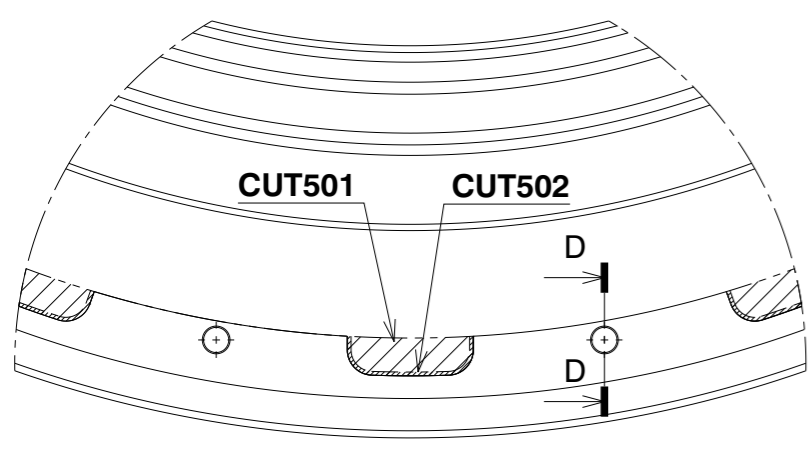

Auxiliary view B  
 Scale: 1:3

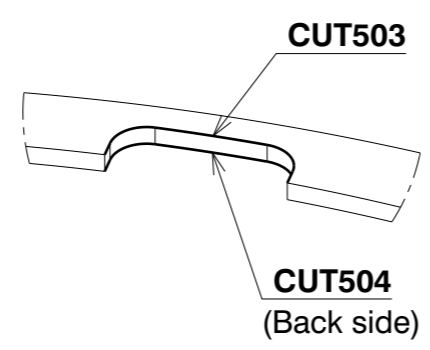

Detail C  
 Scale: 1:2

**CUT 505/506**  
**Holemaking and Chamfering Finish**  
 TID072L22L45S12 (Special)  
 DMP072 AH725  
 AOMT060204-C45

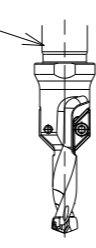

**DrillMeister**

**CUT 505**  
**Holemaking Finish**  
 DSW072-029-08DE3 AH725



**SolidDrill**

**CUT 505/506**  
**Holemaking and Chamfering Finish**  
 TIDCF080-W20  
 TIDC075C8-3  
 DMP075 AH725  
 XCGT060300-45DT GH730

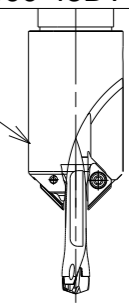

**DrillMeister**

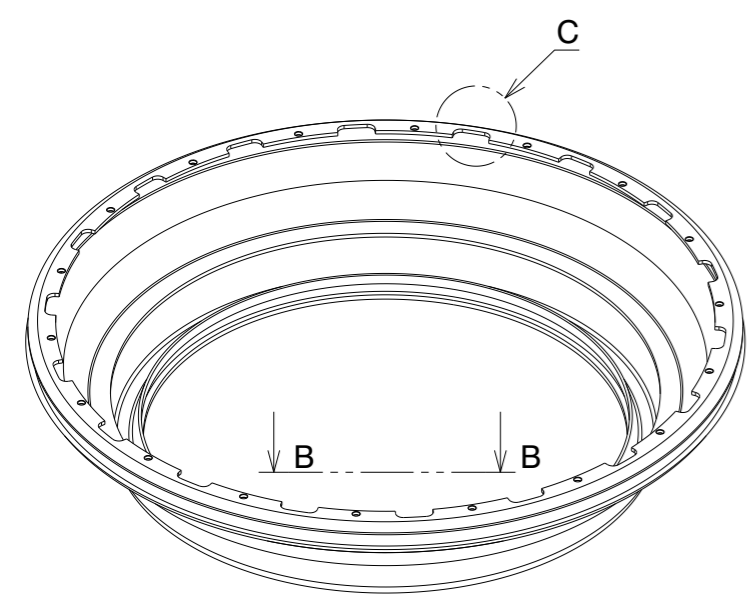

Isometric view  
 Scale: 1:10

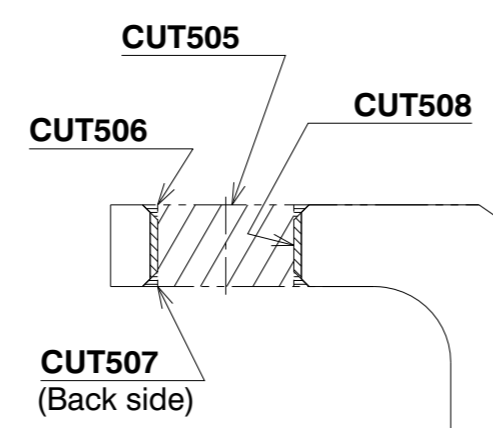

Section cut D-D  
 Scale: 2:1

**CUT 507**  
**Chamfering Finish**  
 KBM-D8.9A45L60S10 (Special)  
 WBGT030102R-W08 SH730

(Scale: 1:1)

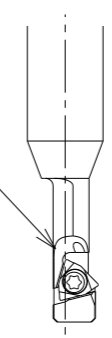

**TungMill**

**CUT 508**  
**Reaming Finish**  
 LK-7.4L70S8Z6 (Special)



**Reamer**

**M/C : Shoulder Milling / Holemaking**

Unspecified Tolerances	Draw		Customer: TUNGALOY	Japan	
	Design				
Dim.s:	Check		Designation:		Dwg.No. 32447993-HC5
	Appr.		LAYOUT OP500-CASING-61143		
Angles:	Scale	-	Process		Page 1 Of 1
			Concept		
	© 2019 Tungaloy Corporation Copyrights Notice		Reg.No.		Rev. No.
			61143/1		
			FL-40030658		A3L