

MODEL IN SCALE 1:5

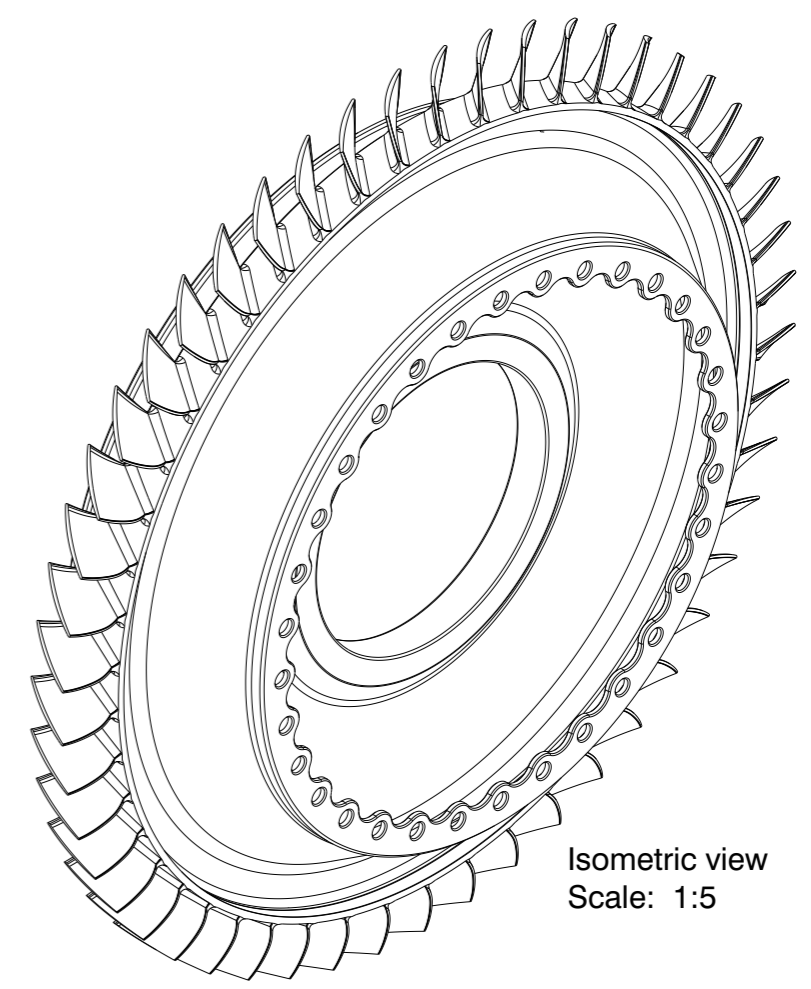

Isometric view
Scale: 1:5

**MACHINE : Vertical Lathe
5-axis Machining Center**

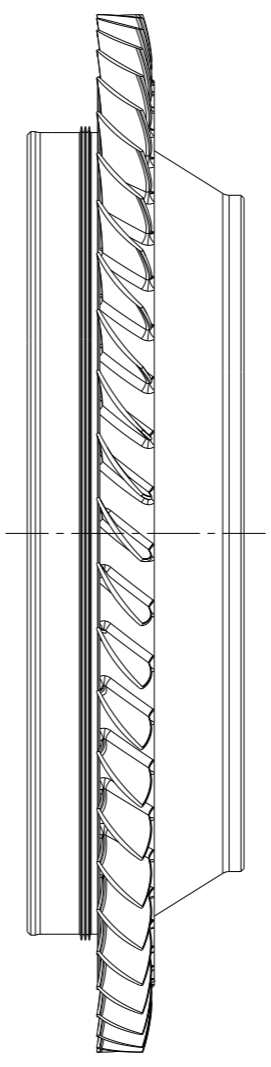
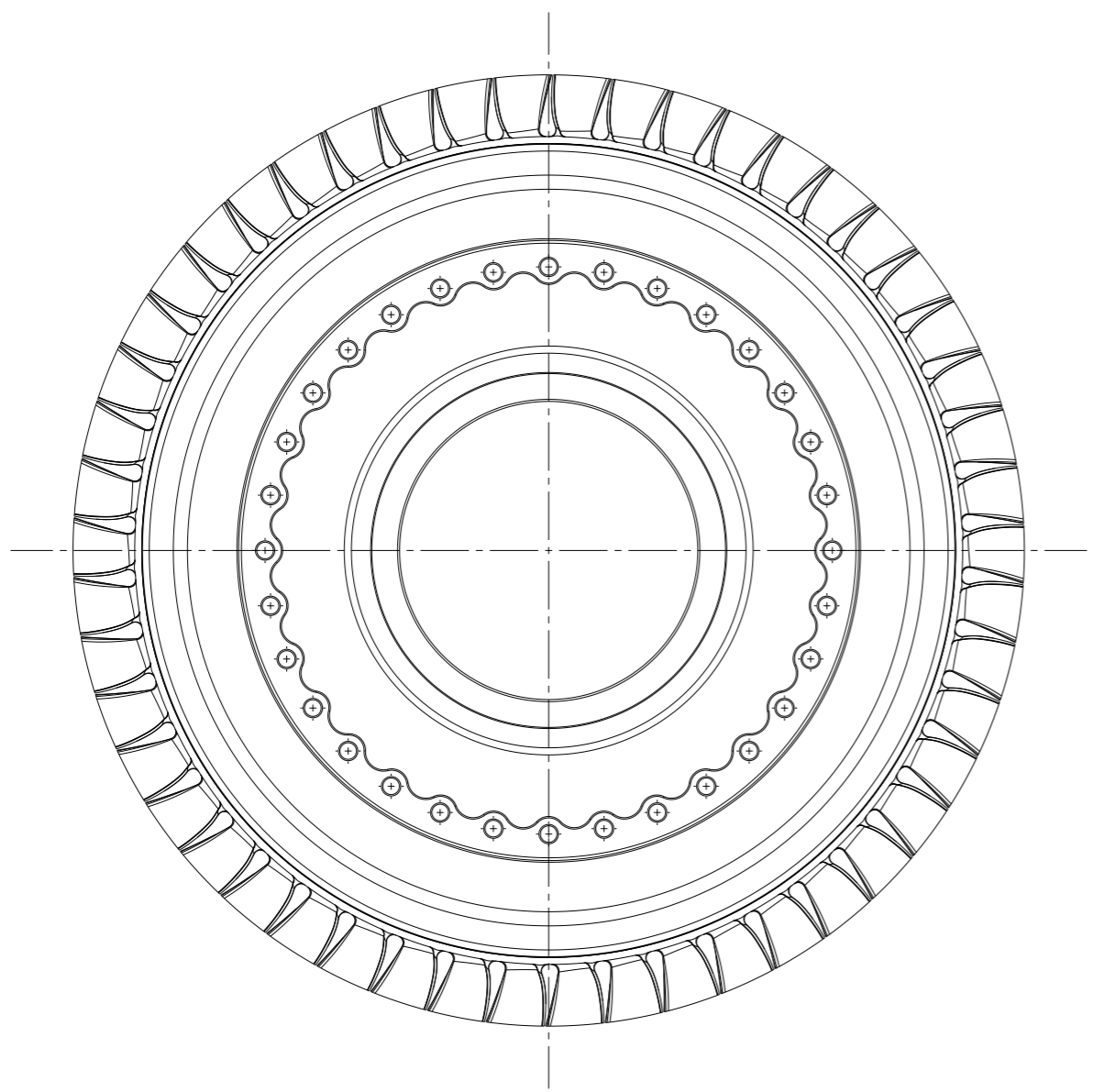
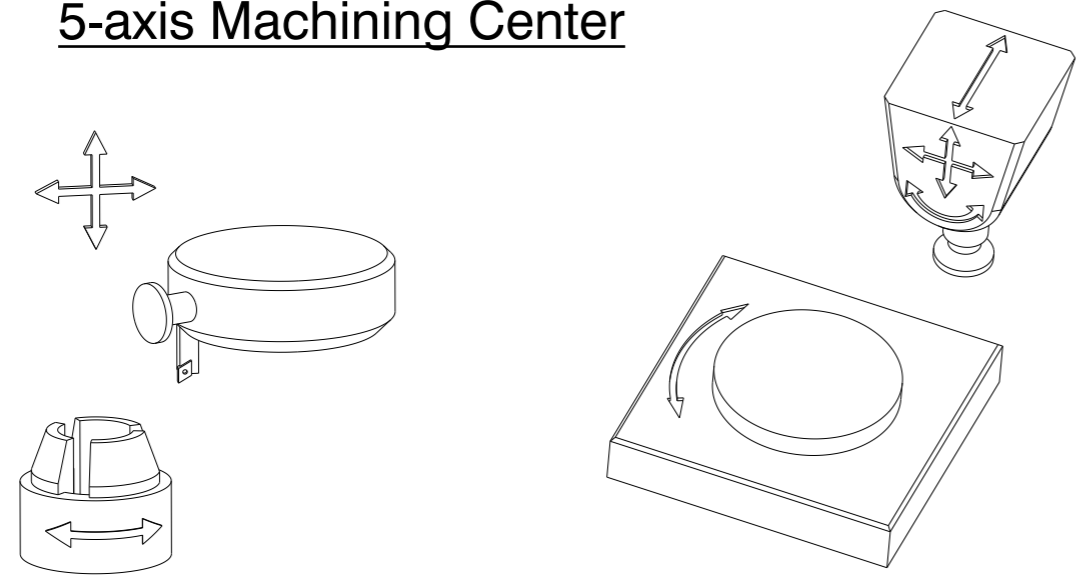

WORKPIECE MATERIAL - Inconel718

BLISK

Unspecified Tolerances	Draw		Customer: TUNGALOY	Japan		
	Design					Designation: LAYOUT-BLISK
Dim.s: --	Check		Process	Layout.	Page 1	
Angles: --	Appr.				Concept	Of 1
	Scale	--			Reg. No.	
	© 2019 Tungaloy Corporation - Copyrights Notice			FL-40032511	62313/1	A3L

MODEL IN SCALE 1:2 TOOLS IN SCALE 1:2

CUT 101
I.D. and Face Turning
S50U-PCLNR12
CNMG120412-HRM AH8015

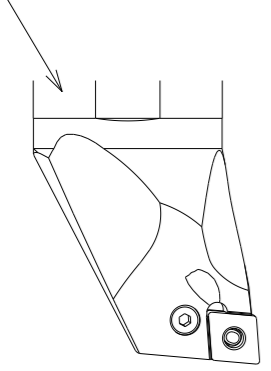

**StreamJetBar
AH8000**

CUT 102
I.D. Grooving
C6-JM-W4R40F55L200 (Special)
DTR4-200 AH8005

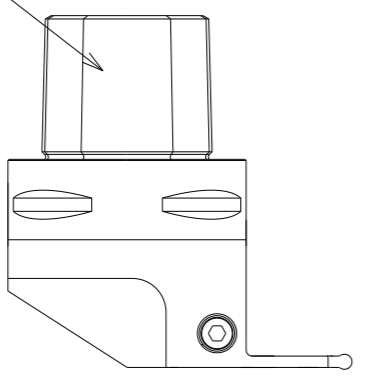

**Special Tool
TungCut
AH8000**

CUT 103
I.D. and Face Turning
JCN-R32F93L150 (Special)
RCGX090700-T1 TS300
RCMM1003M0-61 AH8015

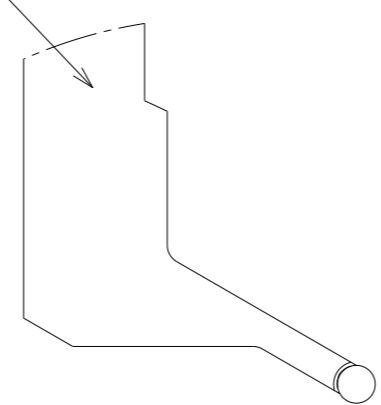

**Special Tool
TS300
AH8000**

CUT 104
Face Turning
VDI40C2C3A-402585-JHPMC
ACLNL2525X-12-CHP-MC
CNMG120412-HRM AH8015

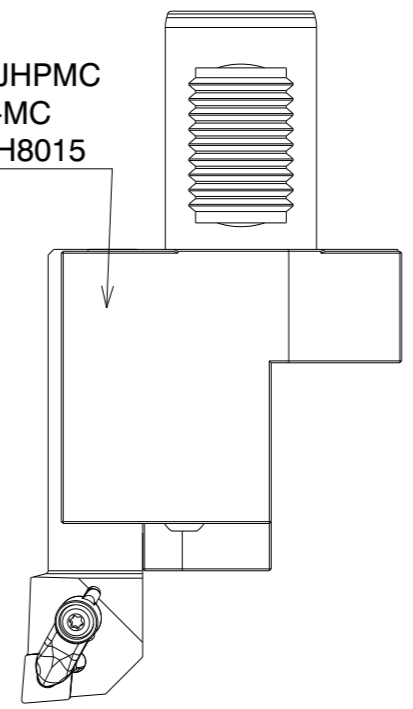

**TungTurnJet
AH8000**

CUT 104 (Option)
Face Turning
PPXOL3232P13-HF
POMG130612-MNW AH8015

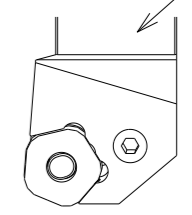

**TurnTenFeed
AH8000**

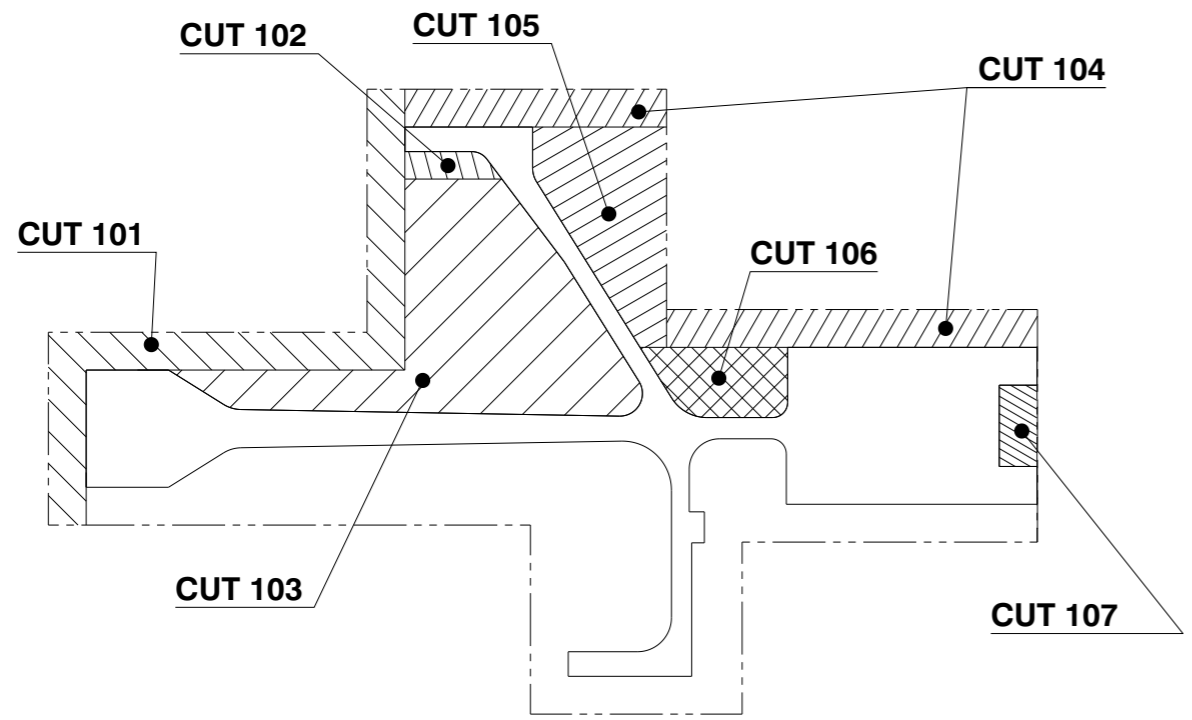

CUT 105
O.D. Turning
C6-NE-LF40L75-CHP (Special)
RCGX120700-E TS300
RCMM1204M0-61 AH8015

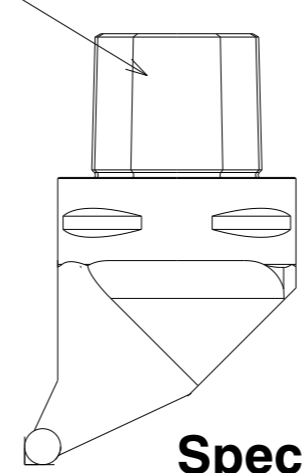

**Special Tool
TS300
AH8000**

CUT 106
Face Grooving
C6-JG-W4LF32L80-CHP (Special)
RCGX090700-T1 TS300
RCMT0602M0-61 AH8015

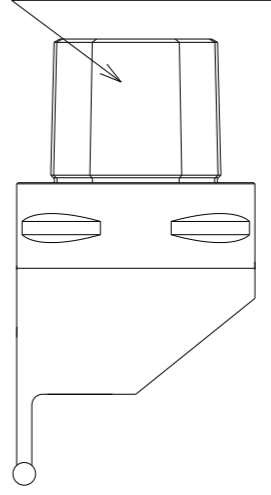

**TS300
AH8000**

CUT 107
O.D. Grooving
CHFVL2525-CHP
CAER-6T20-CHP
DGM6-030 AH8005

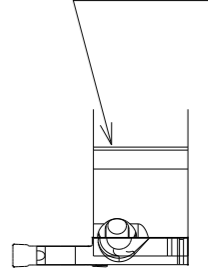

**TungCut
TungTurnJet
AH8000**

Lathe : Rough Turning

Unspecified Tolerances	Draw		Customer: TUNGALOY	Japan	
	Design				
Dim.s: --	Check		Process	Layout.	Page 1 Of 1
	Appr.				
Angles: --	Scale	--	Reg.No. 62313/1		
	© 2019 Tungaloy Corporation Copyrights Notice		FL-40032511		A3L

MODEL IN SCALE 1:2 TOOLS IN SCALE 1:2

CUT 201
I.D. and Face Turning
 S50U-PCLNR12
 CNMG120412-HRF AH8015

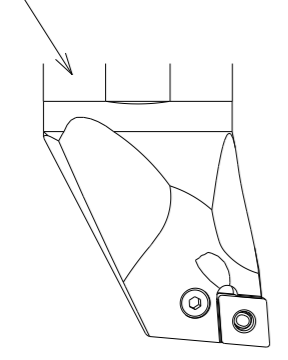

**StreamJetBar
 AH8000**

CUT 202
O.D. and Face Turning
 ACLNL2525X-12-CHP-MC
 CNMG120412-HRF AH8015

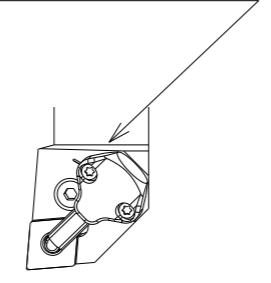

**TungTurnJet
 AH8000**

CUT 202 (Option)
O.D. and Face Turning
 C6PCLNL45065-12-CHP
 2QP-CNGA120408-E BX815

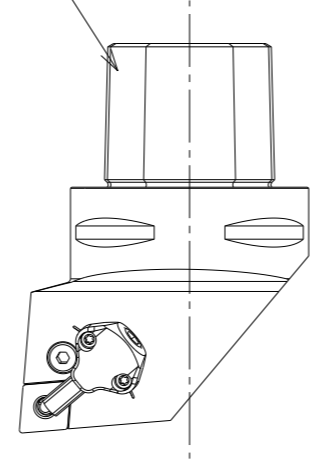

**TungCap
 TungTurnJet
 BX815**

CUT 203
Profiling
 JCG-W4L32F32.5L170 (Special)
 DTR4-200 AH8005

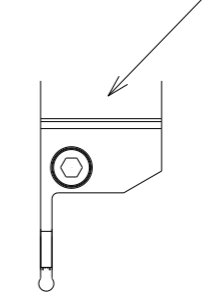

**TungCut
 AH8000**

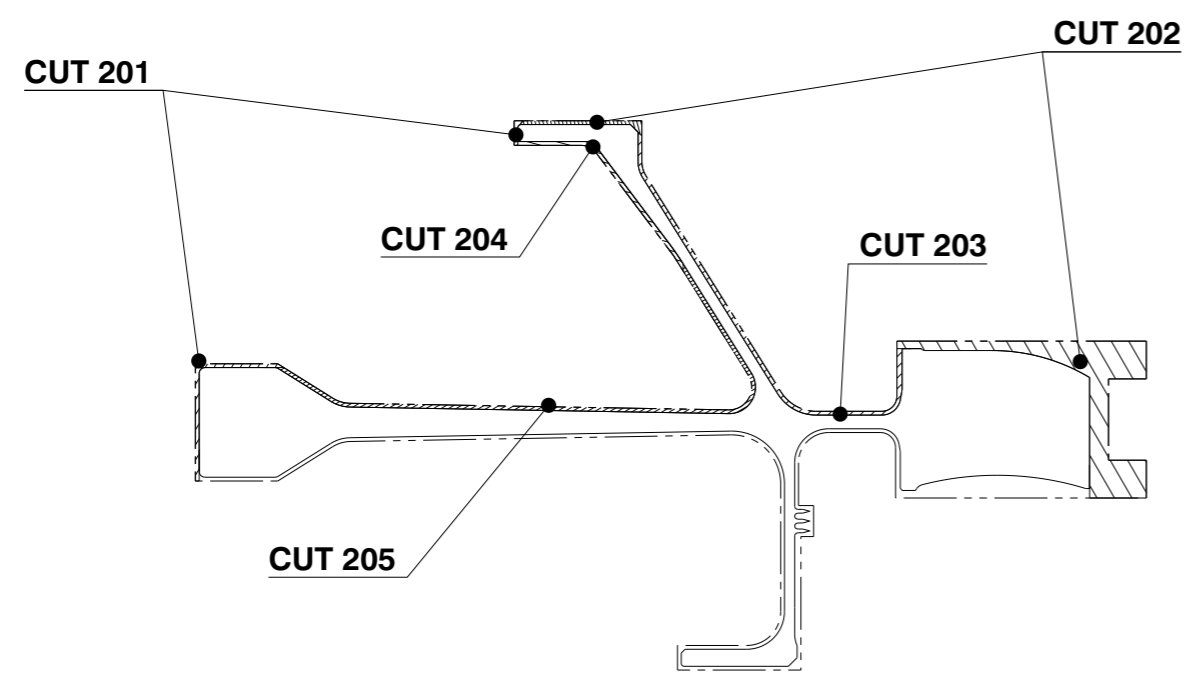

CUT 204
I.D. and Face Turning
 NCN-R32F93L150 (Special)
 RCMM1003M0-61 AH8015

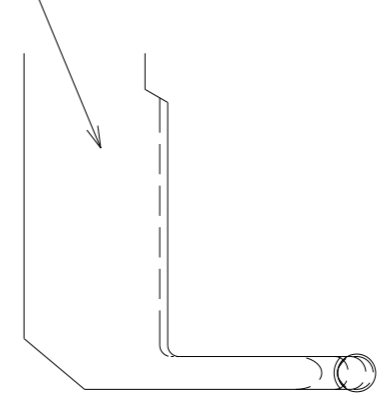

**Special Tool
 AH8000**

CUT 205
I.D. and Face Turning
 NCN-R32F110L150 (Special)
 RCMM1003M0-61 AH8015

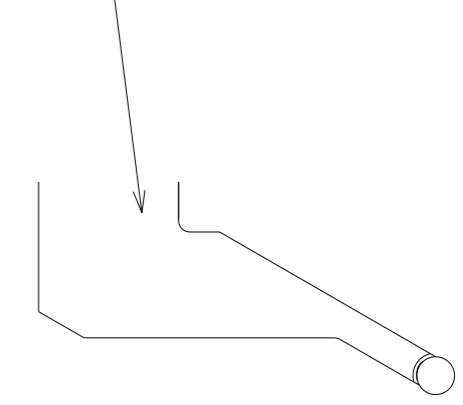

**Special Tool
 AH8000**

Lathe : Finish Turning

Unspecified Tolerances	Draw		Customer: TUNGALOY	Japan	
	Design				
Dim.s: --	Check		Process	Layout.	Page 1 Of 1
	Appr.				
Angles: --	Scale	--	-		Reg.No. 62313/1
			FL-40032511		

© 2019 Tungaloy Corporation
 Copyrights Notice



MODEL IN SCALE 1:1 TOOLS IN SCALE 1:2

CUT 301
Slot Milling (Rough)
 EXN03R020M20.0-04-C
 LNMU0303UER-ML AH8015

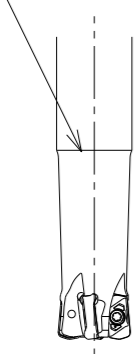

**DoFeed
 AH8000**

CUT 302
Sholder Milling (Rough)
 BT50-RSG 8-170-M75
 HXLS02M016M08R05
 LSMT0202ZER-HM AH8015

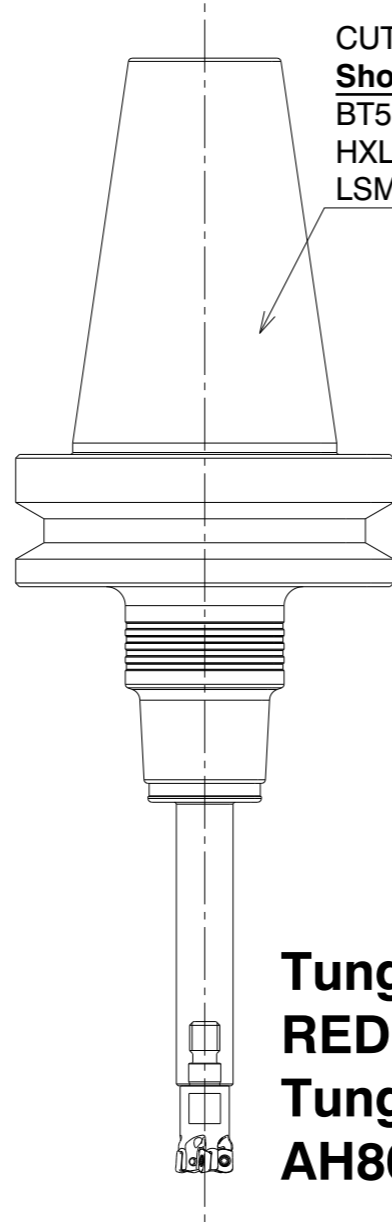

**TungHold
 RED screw arbor (TungFlex)
 TungForceFeed
 AH8000**

CUT 303
Profiling (Semi-Finish)
 VSSD12L110S08-C
 VBN120L15.0R500-6S08 AH715
 VBO120L09.0R300-4S08 AH715 (Option)

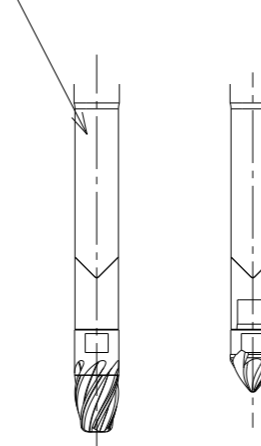

TungMeister

CUT 304
Profiling (Finish)
 Taper Ball Endmill (Special)

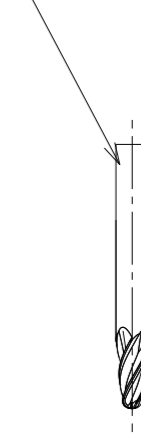

SolidMeister

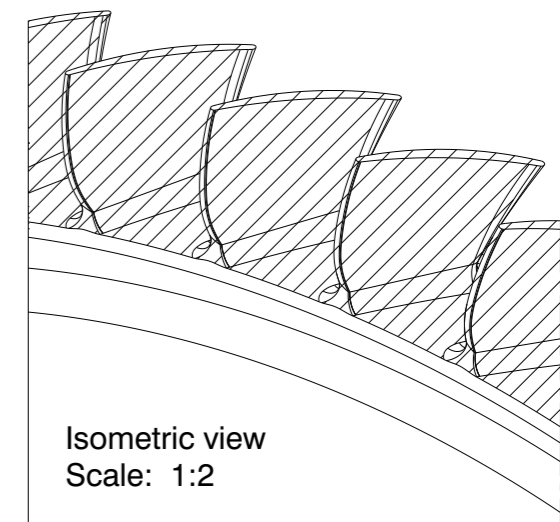
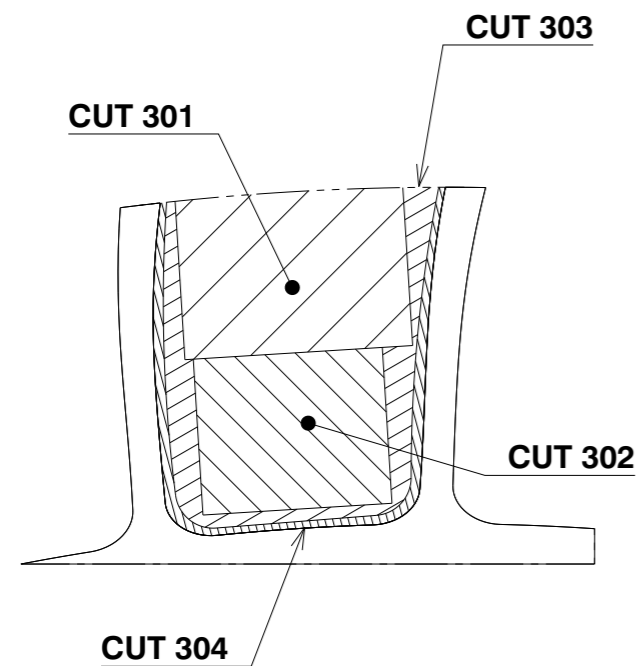

M/C : Rough/Finish Profiling

Unspecified Tolerances	Draw		Customer: TUNGALOY	Japan	
Dim.s: -.-	Design		Designation:	LAYOUT-BLISK	
Angles: -.-	Check		Process	Layout.	Page 1 Rev. No. 1
	Appr.		Scale	Concept	Of 1
	Scale	-.-		-.-	Reg.No. 62313/1
				FL-40032511	A3L

MODEL IN SCALE 1:2 TOOLS IN SCALE 1:1

CUT 401 (Holemaking)
CUT 402 (Bottom Chamfering)

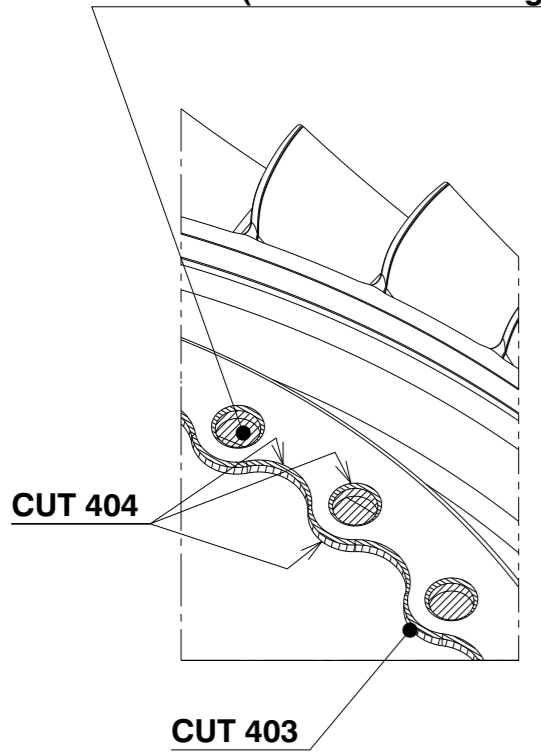

CUT 401
Holemaking
DSW100-035-10DE3 AH725

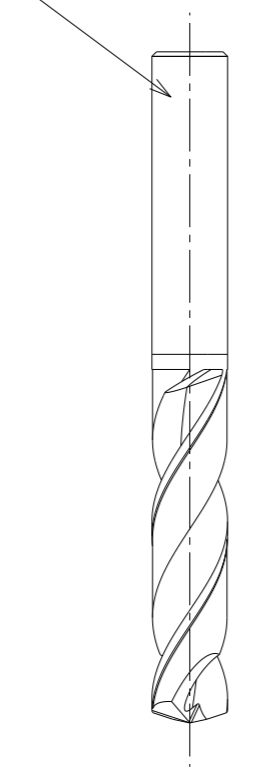

Solid Drill

CUT 402
Bottom Chamfering
KUZ-9L100S16 (Special)
EPGT040102R-W08 SH730

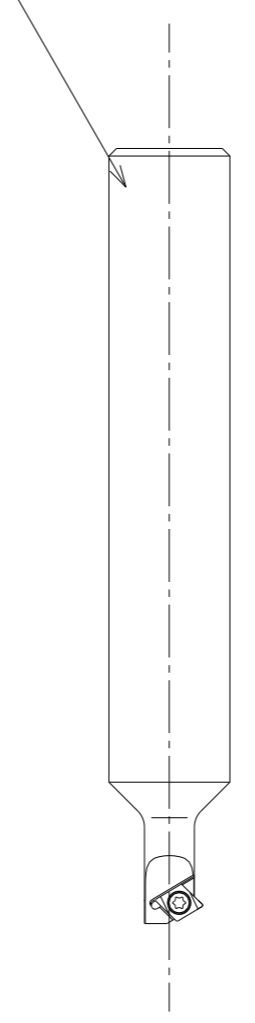

Special Tool

CUT 403
Sholder Milling
VSSD08L070S05-C
VEH080L05.0R05I04S05 AH725

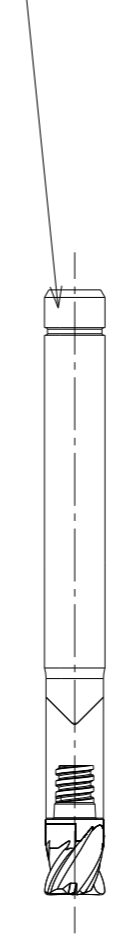

TungMeister

CUT 404
Chamfering / Bottom Chamfering
EASD05M008C12.0R02
SDMT050204PN-MJ AH725

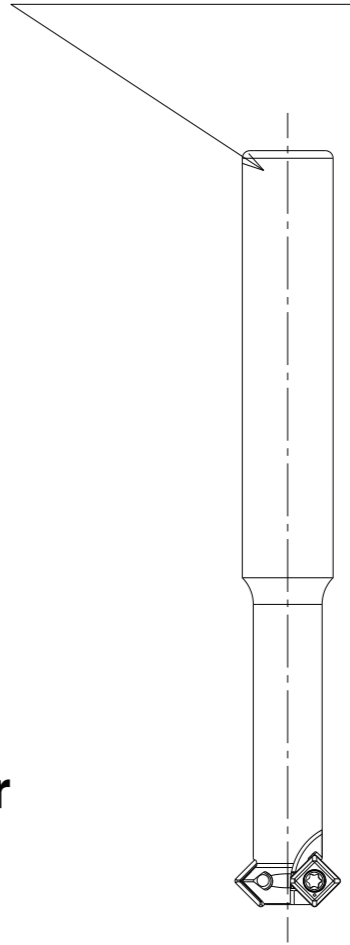

TungQuad

CUT 404 (Option)
Chamfering / Bottom Chamfering
EASD05M008C12.0R02
SDMT050204PN-MJ AH725

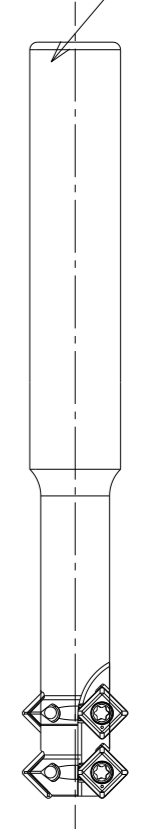

**Special Tool
TungQuad**

**M/C : Holemaking, Chamfering
and Shoulder Milling**

Unspecified Tolerances	Draw		Customer: TUNGALOY	Japan	
	Design		Designation: LAYOUT-BLISK		
Dim.s: -.-	Check		Process	Layout.	Page 1
Angles: -.-	Appr.		Concept		Rev. No. 1
	Scale	-			Reg. No. 62313/1
	© 2019 Tungaloy Corporation - Copyrights Notice			FL-40032511	A3L