

Internal turning tool

BOREMEISTER

Tungaloy Report No. 517S4-G

Expansion of PSC anti-vibration adapters for L/D = 9 and reducer sleeves for anti-vibration bars





Reinforcing the lineup for various ID boring applications

Expansion of PSC anti-vibration adapter for L/D = 9

Applicable for various ID boring applications with wider lineup

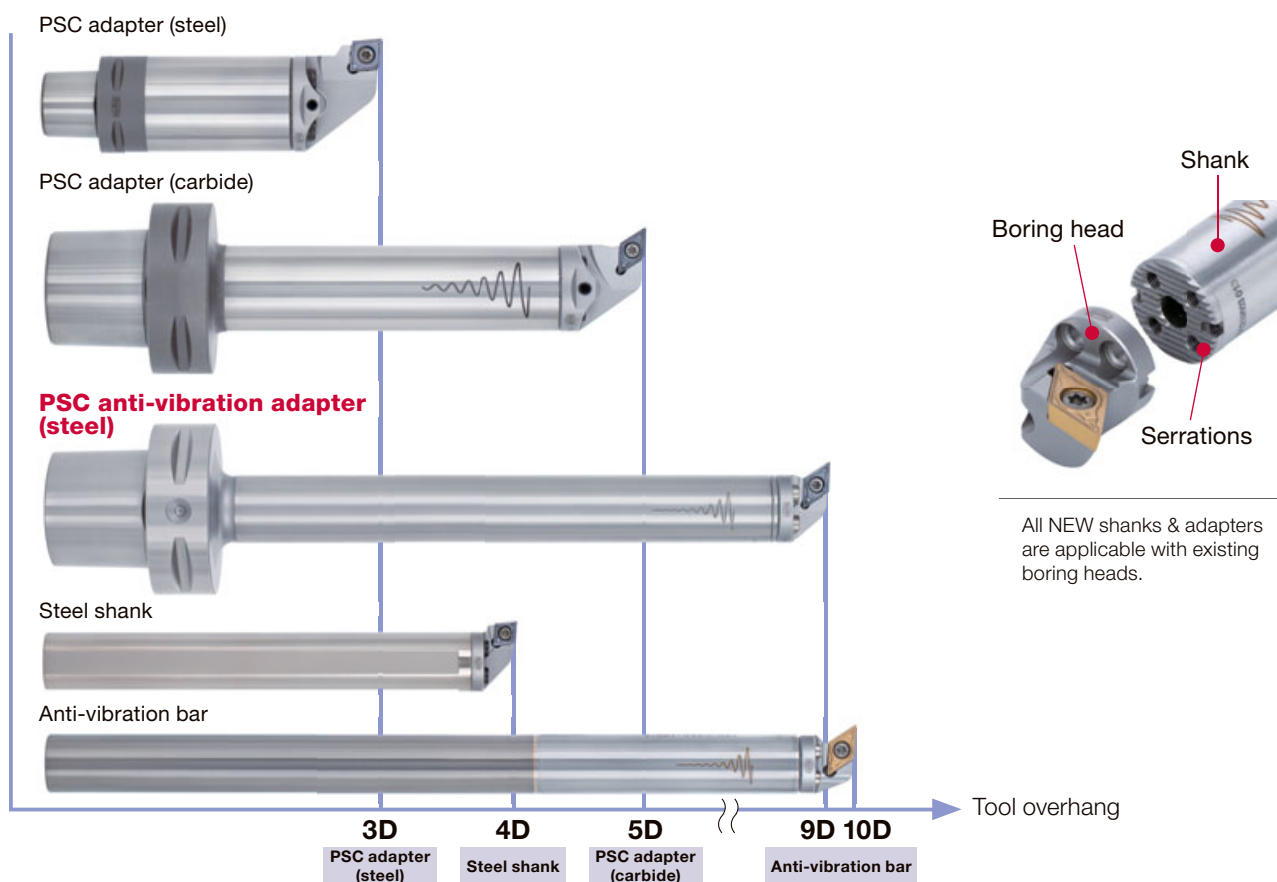

All NEW shanks & adapters are applicable with existing boring heads.

■ Machining comparison of L/D = 5 vs. 9

Tool	PSC anti-vibration adapter (steel) L/D = 9 With anti-vibration system Overhang length = 222 mm	PSC adapter (carbide) L/D = 5 Without anti-vibration system Overhang length = 115 mm
Cutting speed $V_c = 150 \text{ m/min}$ Feed $f = 0.1 \text{ mm/rev}$ Depth of cut $ap = 1.5 \text{ mm}$	<p style="text-align: right; color: green; font-weight: bold;">Good</p>	<p style="text-align: right; color: green; font-weight: bold;">Good</p>
Cutting speed $V_c = 150 \text{ m/min}$ Feed $f = 0.1 \text{ mm/rev}$ Depth of cut $ap = 0.5 \text{ mm}$	<p style="text-align: right; color: green; font-weight: bold;">Good</p>	<p style="text-align: right; color: green; font-weight: bold;">Good</p>

Head : S25-SCLCR09-H
 Insert : CCMT09T304-PS AH725
 Shank size : $\varnothing 25 \text{ mm}$
 Workpiece material : S45C / C45
 Hole diameter : $\varnothing 30 \text{ mm}$
 Machine : NC lathe

BoreMeister L/D = 9 has the same performance as regular L/D = 5 tool with excellent surface quality and precision

Dedicated sleeve for anti-vibration effect enhancement

To maximize anti-vibration capability of BoreMeister, holder clamping stability must be taken into consideration. The use of split sleeve is recommended which can provide a full grip on the cylindrical shank with maximum gripping contact. Do not use a screw clamping method as it may cause damage to the holder and impede anti-vibration capability.



Clamping method

Direct screw clamping with split sleeve

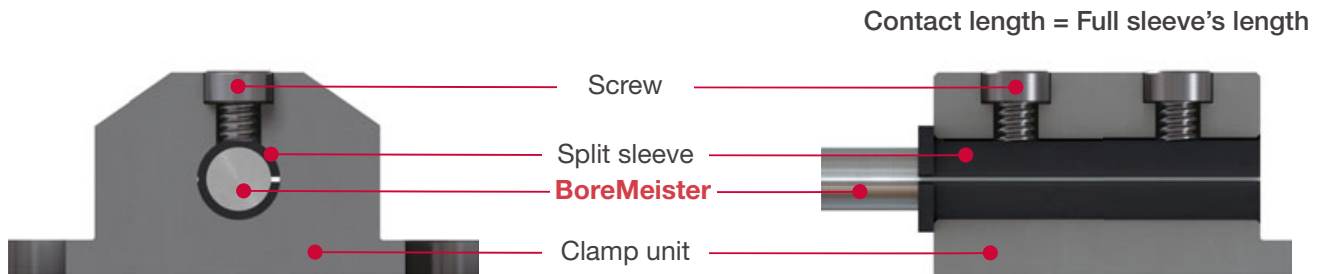

Side screw clamping unit

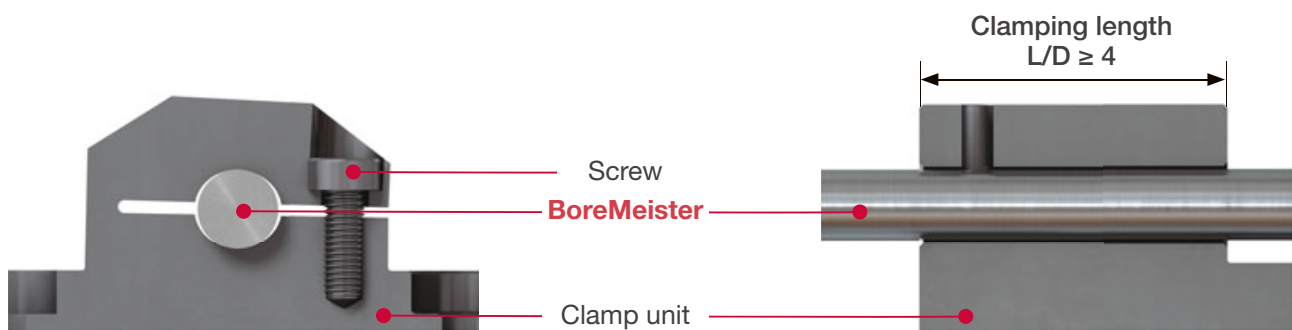

For custom tooling inquiries, contact Tungaloy

C6-9D-C

PSC adapter with anti vibration, L/D = 9

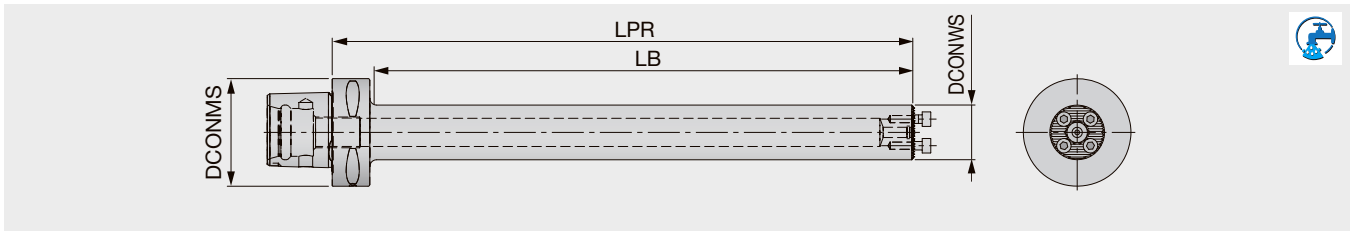

Designation	Material	DCONWS	DCONMS	LPR	LB	WT (kg)
C6-D25-L230-9D-C	Steel	25	63	230.5	200.1	1.65
C6-D32-L288-9D-C	Steel	32	63	288.5	259.5	2.73
C6-D40-L368-9D-C	Steel	40	63	368.5	339	4.45

SPARE PARTS



Designation	Clamping screw	Wrench
C6-D25...	SRM4X12DIN912	HW3.0
C6-D32...	SRM5X12DIN912	HW4.0
C6-D40...	SRM6X16DIN912-12.9	HW5.0

RSL sleeve

Split sleeve for anti-vibration bar

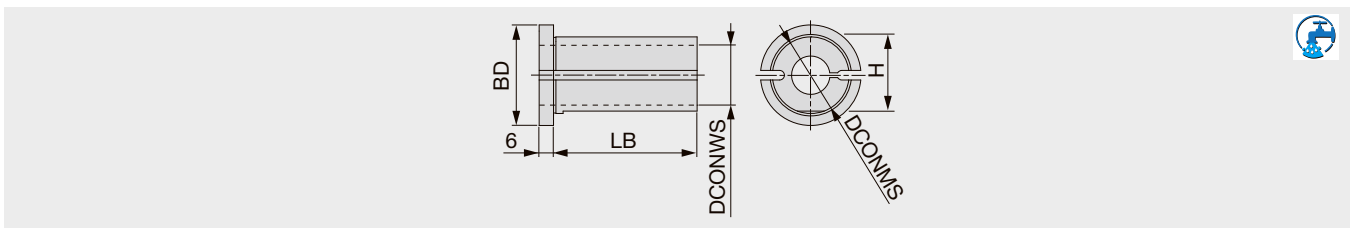

Designation	DCONWS	DCONMS	BD	LB	H
RSL-32-16-L66	16	32	42	60	31
RSL-32-20-L66	20	32	42	60	31
RSL-32-25-L66	25	32	42	60	31
RSL-40-16-L76	16	40	50	70	38.5
RSL-40-20-L76	20	40	50	70	38.5
RSL-40-25-L76	25	40	50	70	38.5



www.tungaloy.com

follow us at:
facebook.com/tungaloyjapan
twitter.com/tungaloyjapan
www.youtube.com/tungaloycorporation



AS9100 Certified
 78006
 2015.11.04
 ISO 14001 Certified
 EC97J1123
 1997.11.26

Distributed by:



FIND US ON THE CLOUD!
machingcloud.com

