

BOREMEISTER

Tungaloy Report No. 517S2-US

**Expanded steel shanks & PSC adapters
for interchangeable boring bar series !!**

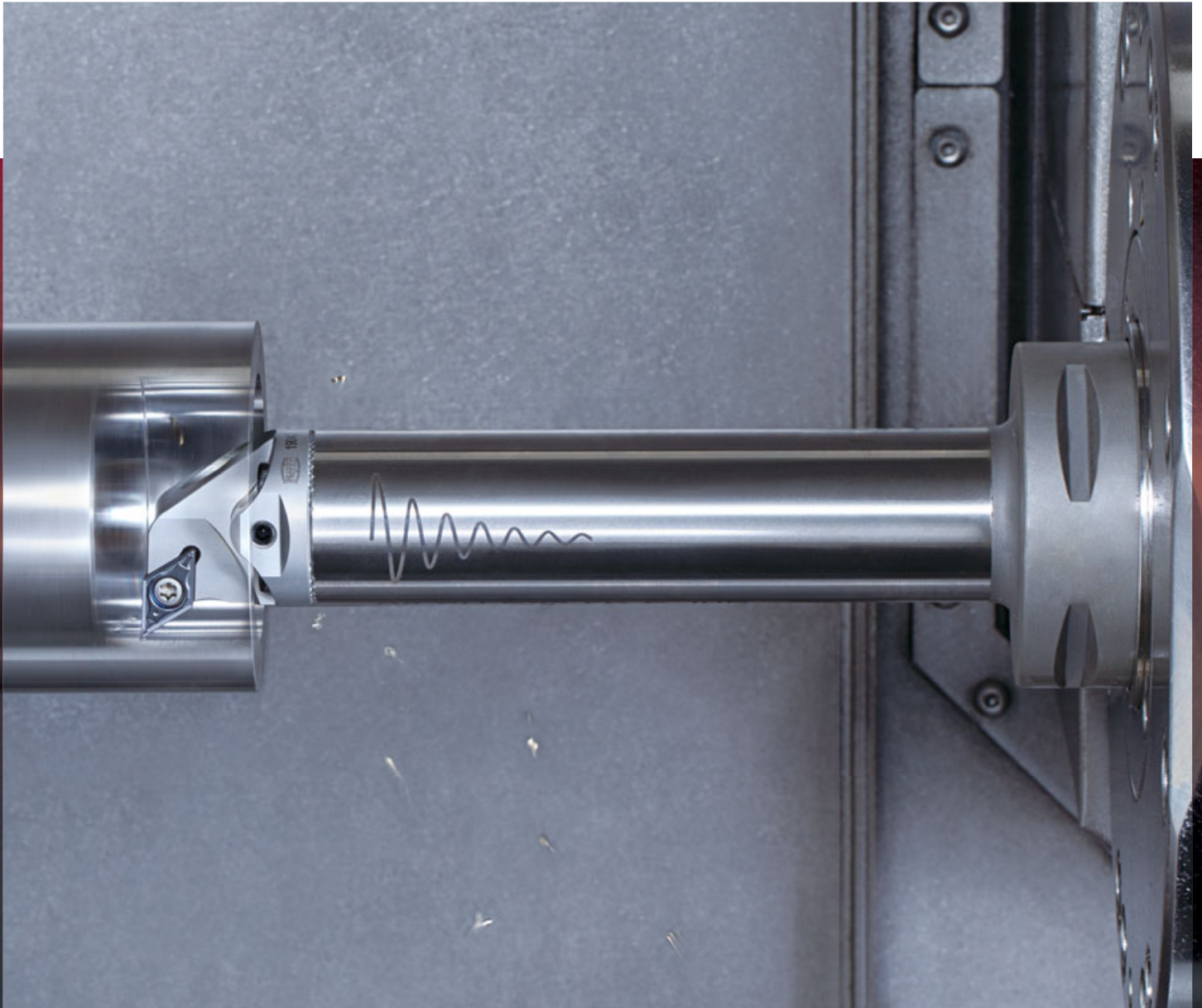



For more information

Expanded lineup for various ID boring applications

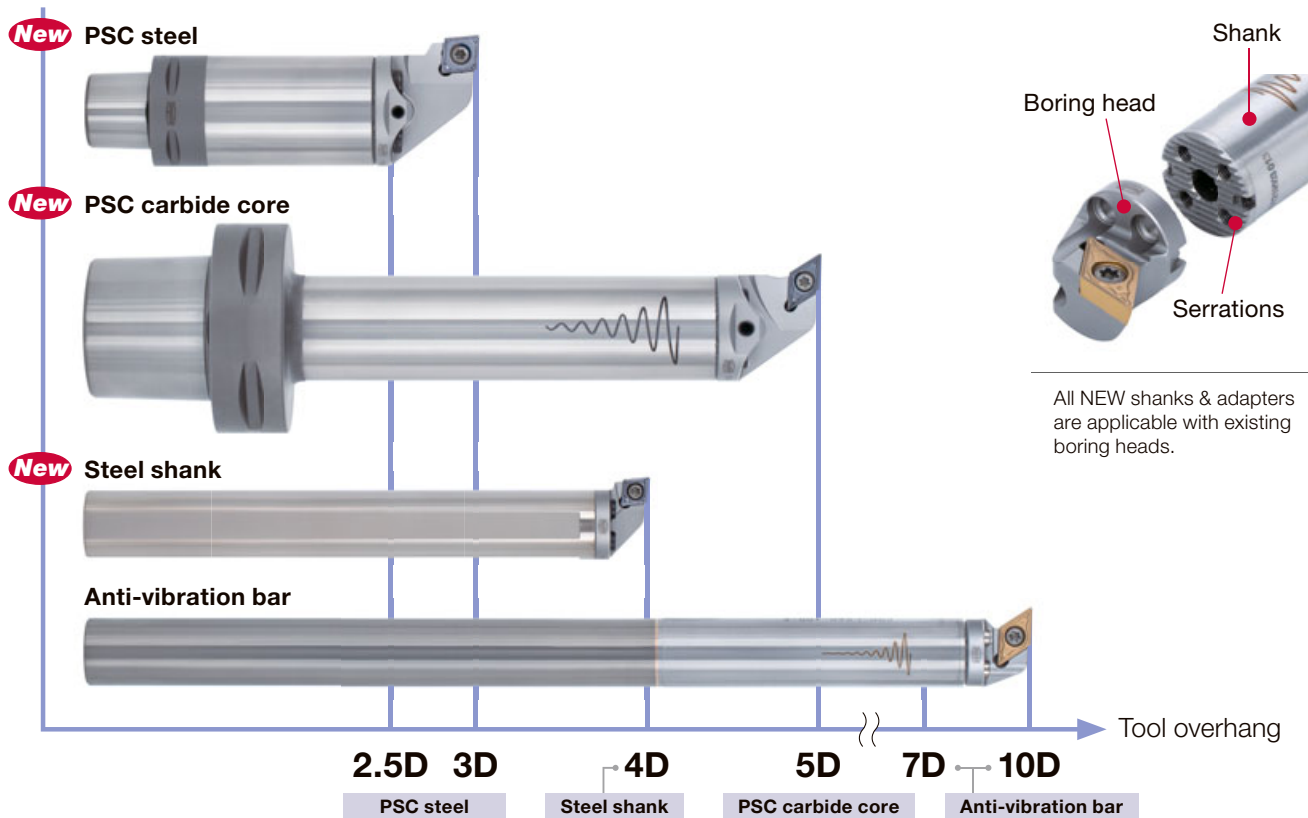

A wide range of cutting heads are available for different insert geometries and latest grades



CUTTING PERFORMANCE

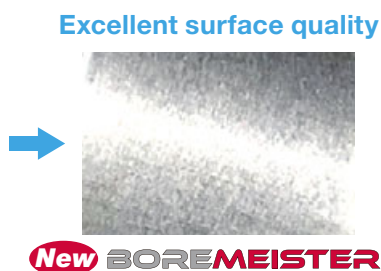

P	Head	: S25-SCLCR09-H
	Shank	: D25-L200-4D-SH (BoreMeister) A25S-SCLCR09-D270 (Conventional)
	Insert	: CCMT 32.51 PS AH725
	Workpiece material	: 1045
	Cutting speed	: $V_c = 394$ sfm
	Feed	: $f = 0.006$ ipr
	Depth of cut	: $a_p = 0.020$ "
	Tool overhang	: L/D = 4
	Coolant	: Wet



C#-SH-CHP / C#-SH-E-CHP

PSC compatible adapter with steel or carbide core

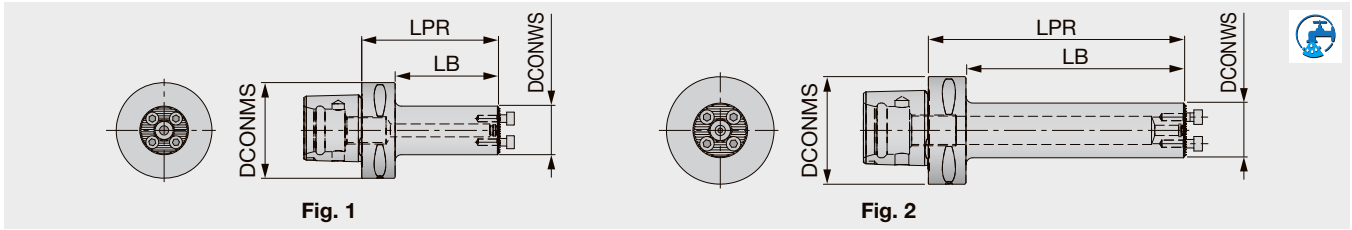

Metric	Material	DCONWS	DCONMS	LPR	LB	Fig
C4-SH-D16-2.5D-CHP	Steel	16	40	40	20	1
C4-SH-D20-2.5D-CHP	Steel	20	40	50	30	1
C4-SH-D25-2.5D-CHP	Steel	25	40	55	35	1
C4-SH-D32-2.5D-CHP	Steel	32	40	75	55	1
C4-SH-D40-3D-CHP	Steel	40	40	80	80	1
C6-SH-D20-5D-E-CHP	Carbide	20	63	100	78	2
C6-SH-D25-5D-E-CHP	Carbide	25	63	115	93	2
C6-SH-D32-5D-E-CHP	Carbide	32	63	150	128	2
C6-SH-D40-5D-E-CHP	Carbide	40	63	185	163	2

SPARE PARTS

Designation	Clamping screw	Wrench
C4**D16...	SRM3X10DIN912	HW2.5
C4/C6**D20...	SR55-2M3.5X10	HW2.5
C4/C6**D25...	SRM4X12DIN912	HW3.0
C4/C6**D32...	SRM5X12DIN912	HW4.0
C4/C6**D40...	SRM6X16DIN912-12.9	HW5.0

D#4D-SH

Steel shank for internal turning, with through coolant

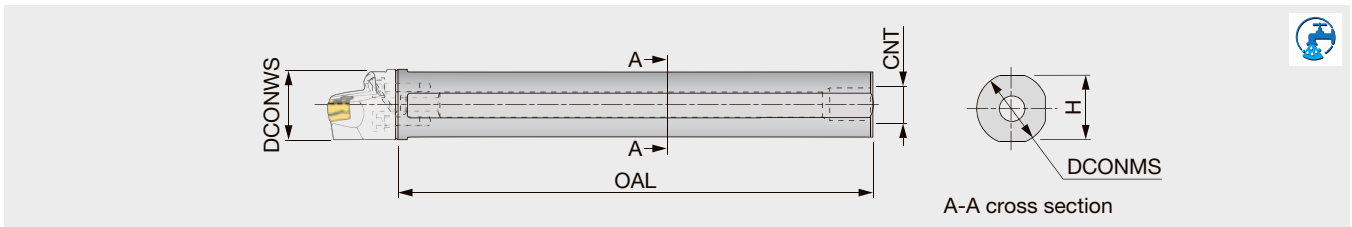

Inch	Material	DCONWS	DCONMS	OAL	CNT	H
D1.00-L7.2-4D-SH	Steel	1.000	1.000	7.200	UNF-2B 1/2"-20	0.921
D1.25-L8.74-4D-SH	Steel	1.250	1.250	8.740	UNF-2B 1/2"-20	1.142
D1.50-L10.75-4D-SH	Steel	1.575	1.500	10.75	UNF-2B 1/2"-20	1.339
D2.00-L14.72-4D-SH	Steel	1.575	2.000	14.72	UNF-2B 1/2"-20	1.811
D2.50-L18.74-4D-SH	Steel	1.575	2.500	18.74	UNF-2B 1/2"-20	2.283

SPARE PARTS

Designation	Clamping screw	Wrench
D1.00-L7.2-4D-SH	SR M4X12DIN912	HW 3.0
D1.25-L8.74-4D-SH	SR M5X12 DIN912	HW 4.0
D1.50-L10.75-4D-SH	SRM6X16DIN912-12.9	HW 5.0
D2.00-L14.72-4D-SH	SRM6X16DIN912-12.9	HW 5.0
D2.50-L18.74-4D-SH	SRM6X16DIN912-12.9	HW 5.0

Tungaloy America, Inc.

3726 N Ventura Drive, Arlington Heights, IL 60004, U.S.A.

Inside Sales: +1-888-554-8394

Technical Support: +1-888-554-8391

Fax: +1-888-554-8392

www.tungaloy.com/us

Tungaloy Canada

432 Elgin St. Unit 3, Brantford, Ontario N3S 7P7, Canada

Phone: +1-519-758-5779 Fax: +1-519-758-5791

www.tungaloy.com/ca

Tungaloy de Mexico S.A.

C Los Arellano 113, Parque Industrial Siglo XXI

Aguascalientes, AGS, Mexico 20290

Phone: +52-449-929-5410 Fax: +52-449-929-5411

www.tungaloy.com/mx



Scan for instant
web access



www.tungaloy.com/us

follow us at:

facebook.com/tungaloyamerica

twitter.com/tungaloy

instagram.com/tungaloyamerica

linkedin.com/company/tungaloy-america

To see Tungaloy product in action visit:



www.youtube.com/tungaloycorporation

Distributed by:



FIND US ON THE CLOUD!
machiningcloud.com

