

TurnLine

**BOREMEISTER**



[www.tungaloy.com/us](http://www.tungaloy.com/us)

Tungaloy Report No. 517-US

## Vibration-Free Solution for Deep-Hole Boring

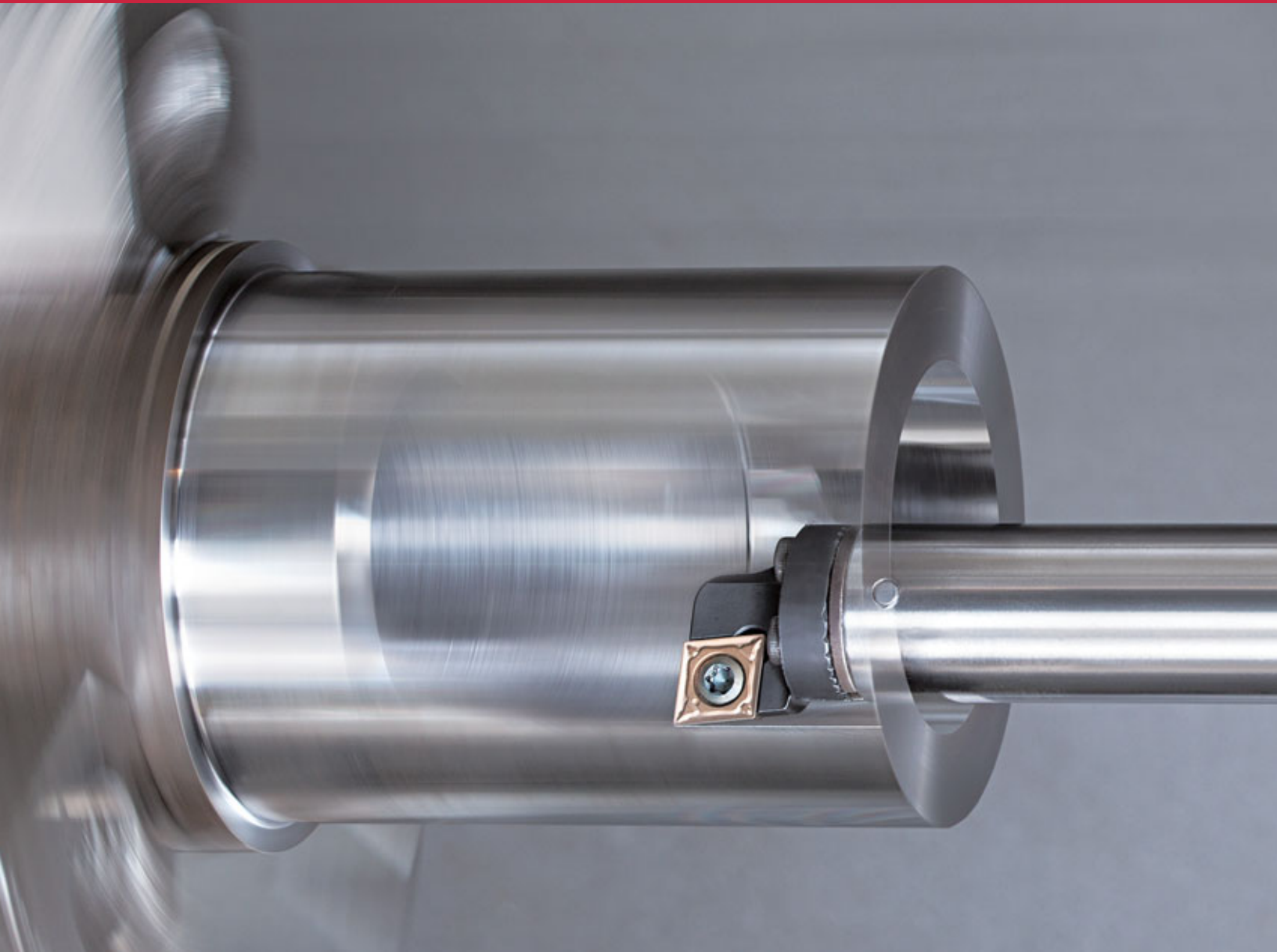

**INDUSTRY 4.0**  
*FEED the SPEED!*



ACCELERATED MACHINING





---

The ultimate solution for overcoming tool overhang challenges of up to  $L/D = 10$

---

Unique anti-vibration mechanism in the tool body reduces vibration during deep hole boring with long overhangs of up to **L/D = 10**

- Minimum bore diameter:  $\varnothing 0.787''$
- Internal coolant supply improves chip evacuation during deep hole machining
- Various types of cutting heads are available to accommodate different insert shapes

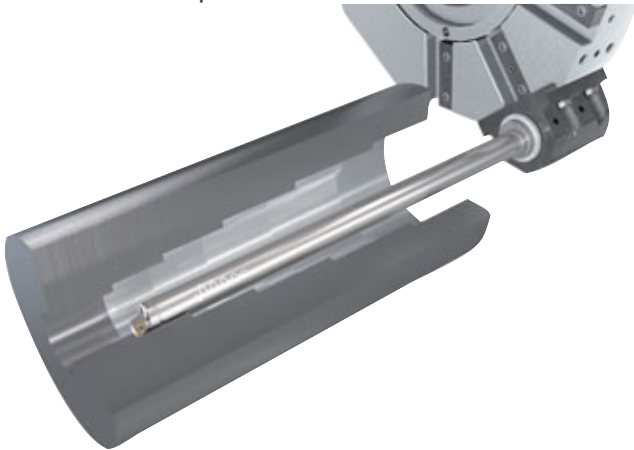

## Vibration Dampening Mechanism

When cutting forces create vibration on a boring bar set up with long overhangs, the bar's dampening mechanism counters the tool's motion and cancels the vibration.

The dampening mechanism consists of a weight supported by spring elements.

The vibrations die out quickly eliminating noise and chatter marks.

- Concept image of dampening mechanism

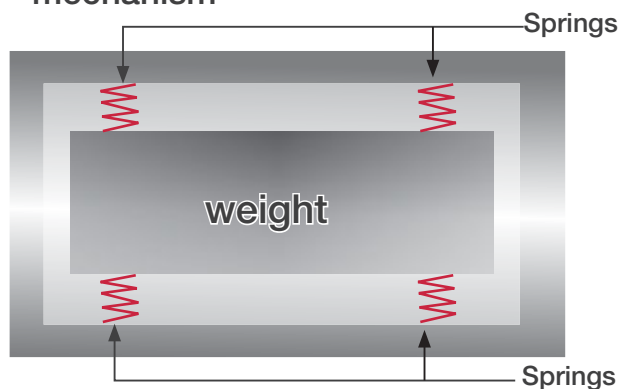

- Tool vibration with and without vibration damper

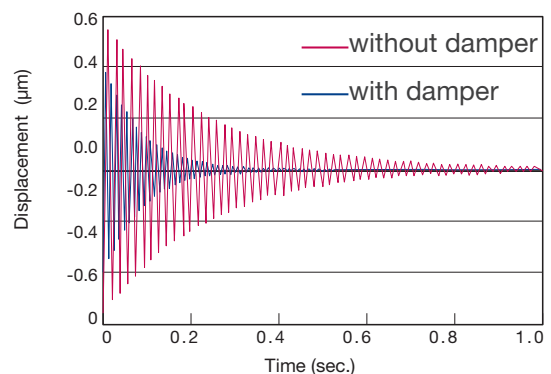

## Standard Lineup

### BoreMeister anti-vibration bars

L/D	Shank diameter (inch)						
	ø0.625	ø0.750	ø1.000	ø1.250	ø1.500	ø2.000	ø2.500
7	○	○	○	○	△	△	△
10	●	●	○	○	△	△	△

- : steel shank
- : carbide shank
- △ : on demand

### BoreMeister head

Insert shape	Shank diameter (inch)				
	ø0.625	ø0.750	ø1.000	ø1.250	ø1.500, ø2.000, ø2.500
CCMT	○	○	○	○	△
DCMT	○	○	○	○	△
VCMT		○	○	△	△
DNMG				△	△
VNMG					△

- : standard
- △ : on demand

BoreMeister is comprised of the anti-vibration bar and interchangeable boring head, featuring serrated interfaces for high precision indexing. They are connected by screws, allowing the fitting of a wide range of cutting heads for increased flexibility.

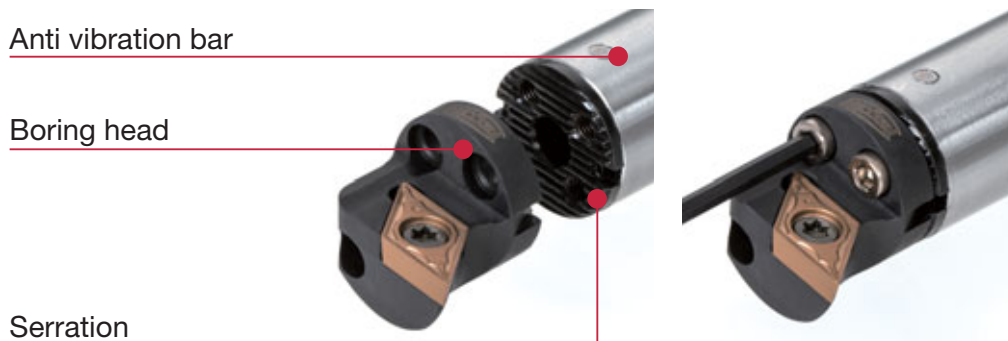

## Boring bar selection guide

For machining of long overhangs over  $5xL/D$ , the use of an anti-vibration bar is highly effective.

### Tool selection according to length-to-diameter ratio

Steel shank	Carbide reinforced	Carbide shank	BoreMeister
$L/D \leq 3$	$L/D \leq 4$	$L/D \leq 5$	$L/D \leq 10$

For custom tooling inquiries, contact Tungaloy



## General use recommendations

### 1. Machine clamping recommendation

For BoreMeister to maximize its vibration dampening capability, clamping stability is extremely important. When clamping the cylindrical boring bar, Tungaloy recommends the use of split sleeve holders, which encompass the tool shank, securing maximum contact area. Never use a conventional screw clamp method as it may damage the tool and will not properly prevent vibration.

#### Clamping method

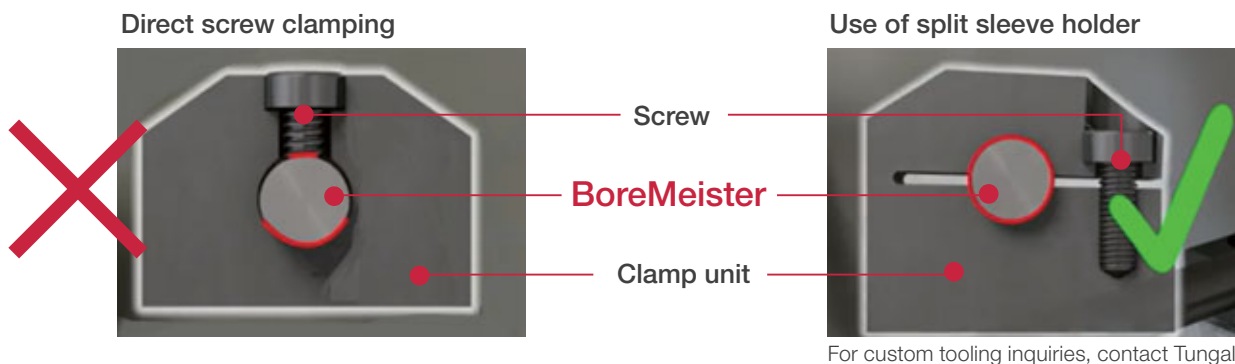

Clamping length of BoreMeister should be  $L/D = 4$  or more.

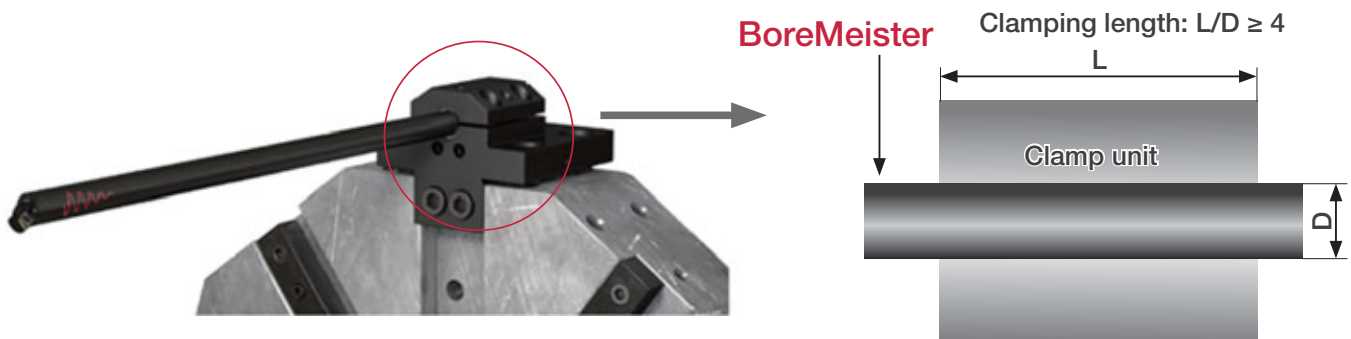

### 2. Center height positioning

Precise center height positioning is another important factor to achieve the right dimensional tolerances and surface finish. BoreMeister has no flats on its cylindrical shank to secure the tool center. Use a dial gauge to properly adjust the tool center height while fine-sliding the boring head on the serrated interface.

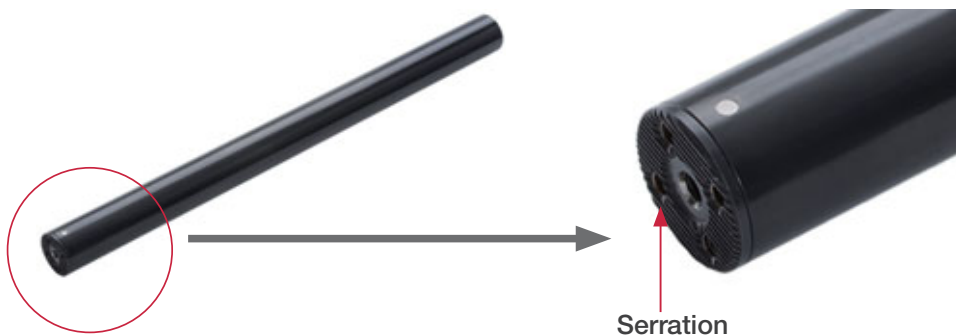

## S-SCLCR/L-H

Screw-on clamp interchangeable boring heads for positive 80° rhombic inserts

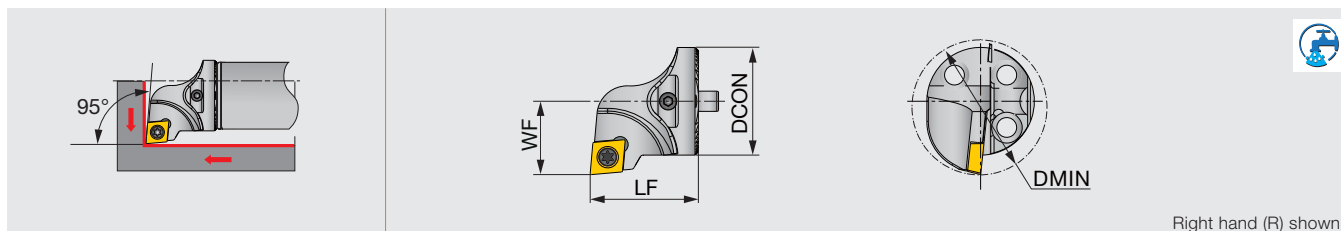

Right hand (R) shown.

Inch	DMIN	DCON	WF	LF	Shank size	Insert
S16-SCLCR/L06-H	0.787	0.630	0.433	0.787	D/G.625	CC**0602...
S20-SCLCR/L09-H	0.984	0.787	0.512	0.787	D/G.750	CC**09T3...
S25-SCLCR/L09-H	1.260	0.984	0.669	0.787	D1.00	CC**09T3...
S32-SCLCR/L09-H	1.575	1.260	0.866	1.260	D1.25	CC**09T3...
S40-SCLCR/L12T-H	1.968	1.575	1.063	1.496	D1.50, D2.00, D2.50	CC**1204...

Note: When using a right or left hand insert, the right hand insert (R) is used for the left hand toolholders (SCLCL\*\* type), and the left hand insert (L) is used for the right hand toolholders (SCLCR\*\* type).

### SPARE PARTS

Designation	Clamping screw	Wrench	Shim	Shim screw
S16-SCLCR/L06-H	SR14-548	T-7/5	-	-
S20-SCLCR/L09-H	SR16-236	T-15/5	-	-
S25-SCLCR/L09-H	SR16-236	T-15/5	-	-
S32-SCLCR/L09-H	SR16-236	T-15/5	-	-
S40-SCLCR/L12T-H	SR16-212	T-20/5	TCC4-2	SRTC-4



## S-SDUCR/L-H

Screw-on clamp interchangeable boring heads for positive 55° rhombic inserts

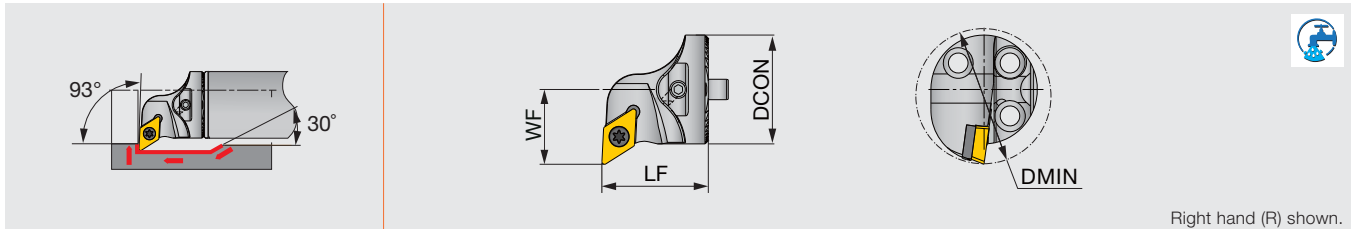

Inch	DMIN	DCON	WF	LF	Shank size	Insert
S16-SDUCR/L07-H	0.787	0.630	0.433	0.787	D/G.625	DC**0702...
S20-SDUCR/L11-H	0.984	0.787	0.512	0.787	D/G.750	DC**11T3...
S25-SDUCR/L11-H	1.260	0.984	0.669	0.787	D1.00	DC**11T3...
S32-SDUCR/L11T-H	1.575	1.260	0.866	1.260	D1.25	DC**11T3...
S40-SDUCR/L11T-H	1.969	1.575	1.063	1.260	D1.50, D2.00, D2.50	DC**11T3...

Note: When using a right or left hand insert, the right hand insert (R) is used for the left hand toolholders (SDUCL\*\* type), and the left hand insert (L) is used for the right hand toolholders (SDUCR\*\* type).

### SPARE PARTS

Designation	Clamping screw	Wrench	Shim	Shim screw
S16-SDUCR/L07-H	SR14-548	T-7/5	-	-
S20-SDUCR/L11-H	SR16-236P	T-15/5	-	-
S25-SDUCR/L11-H	SR16-236P	T-15/5	-	-
S32-SDUCR/L11T-H	SR16-236P	T-15/5	TDC3-1P	SRTC-3P
S40-SDUCR/L11T-H	SR16-236P	T-15/5	TDC3-1P	SRTC-3P

## S-SVUCR/L-H

Screw-on clamp interchangeable boring heads for positive 35° rhombic inserts

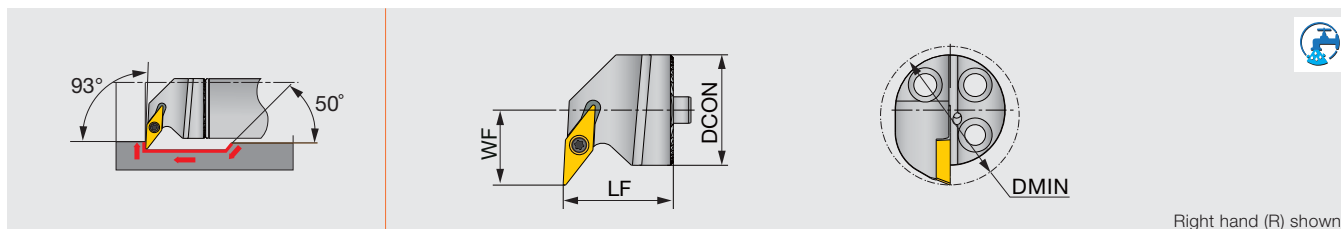

Right hand (R) shown.

Inch	DMIN	DCON	WF	LF	Shank size	Insert
S20-SVUCR/L11-H	1.063	0.787	0.630	0.787	D/G.750	VC**1103...
S25-SVUCR/L11-H	1.260	0.984	0.669	0.984	D1.00	VC**1103...

Note: When using a right or left hand insert, the right hand insert (R) is used for the left hand toolholders (SVUCL\*\* type), and the left hand insert (L) is used for the right hand toolholders (SVUCR\*\* type).

### SPARE PARTS



Designation	Clamping screw	Wrench
S20-SVUCR/L11-H	SR14-560	T-8/5
S25-SVUCR/L11-H	SR14-560	T-8/5

## S-SVLCR/L-H

Screw-on clamp interchangeable boring heads for positive 35° rhombic inserts

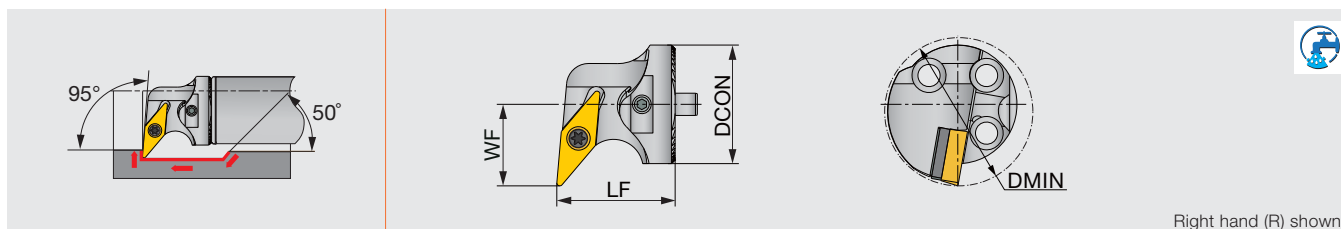

Right hand (R) shown.

Inch	DMIN	DCON	WF	LF	Shank size	Insert
S32-SVLCR/L16T-H	1.575	1.260	0.866	1.260	D1.25	VC**1604...
S40-SVLCR/L16T-H	1.968	1.575	1.063	1.260	D1.50, D2.00, D2.50	VC**1604...

Note: When using a right or left hand insert, the right hand insert (R) is used for the left hand toolholders (SVLCL\*\* type), and the left hand insert (L) is used for the right hand toolholders (SVLCR\*\* type).

### SPARE PARTS



Designation	Clamping screw	Wrench	Shim	Shim screw
S32-SVLCR/L16T-H	SR16-236P	T-15/5	TVC 3-1P	SRTC-3P
S40-SVLCR/L16T-H	SR16-236P	T-15/5	TVC 3-1P	SRTC-3P

## S-DDUNR/L-H

Double clamp interchangeable boring heads for negative 55° rhombic inserts

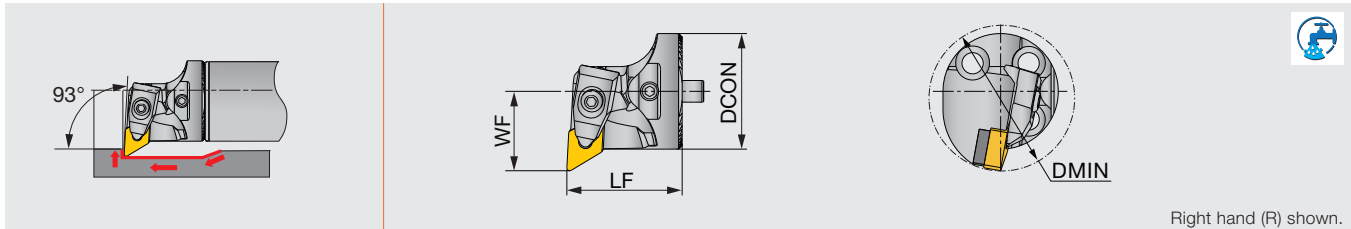

Right hand (R) shown.

Inch	DMIN	DCON	WF	LF	Shank size	Insert
S32-DDUNR/L11T-H	1.575	1.260	0.866	1.260	D1.25	DN**33...
S40-DDUNR/L15T-H <sup>(1)</sup>	1.968	1.575	1.063	1.496	D1.50, D2.00, D2.50	DN**44...

Note: When using a right or left hand insert, the right hand insert (R) is used for the left hand toolholders (DDUNL\*\* type), and the left hand insert (L) is used for the right hand toolholders (DDUNR\*\* type).

(1) DN\*\*43... inserts require a separate shim (# RDT443).

### SPARE PARTS

Designation	Shim 1	Shim 2 (Optional)	Shim screw	Clamp	Clamping screw	Spring	Wrench
S32-DDUNR/L11T-H	RDT3-2	-	SR40085I	LCGR-3	SRRC3	KSP3	HW2.5
S40-DDUNR/L15T-H	RDT433	(RDT443)	SR14-506	DLM4	DLS4	DSP4	HW3.0

## S-DVUNR/L-H

Double clamp interchangeable boring heads for negative 35° rhombic inserts

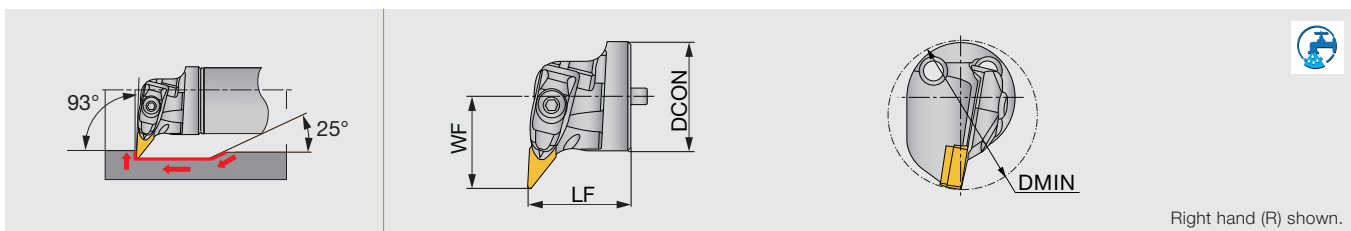

Right hand (R) shown.

Inch	DMIN	DCON	WF	LF	Shank size	Insert
S40-DVUNR/L16T-H	2.205	1.575	1.339	1.496	D1.50, D2.00, D2.50	VN**33...

### SPARE PARTS

Designation	Shim	Shim screw	Clamp	Clamping screw	Spring	Wrench
S40-DVUNR/L16T-H	ASV322	SR35080I	DLM3V	SR10402267	KSP5	HW4.0

## Straight Shank

Anti-vibration bars with through coolant for interchangeable turning heads

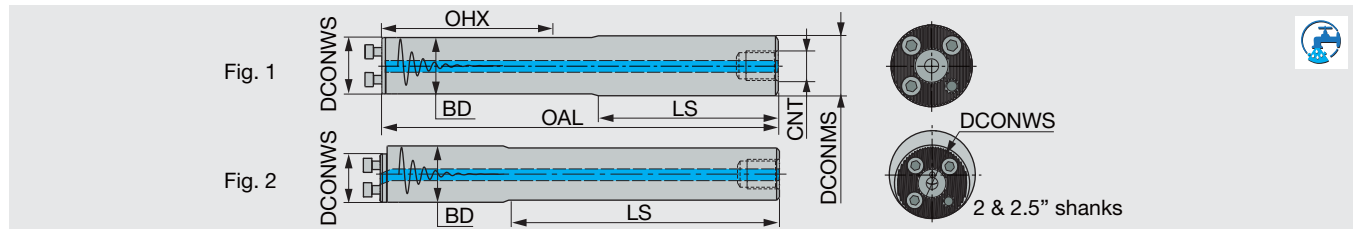

Inch	Material	DCONWS	DCONMS	BD	OAL	LS	OHX	CNT	Fig.
D.625-L6.14-7D-C	Steel	0.630	0.625	0.630	6.140	3.600	3.500	G1/8	1
G.625-L8.03-10D-E	Carbide	0.630	0.625	0.630	8.030	5.220	5.500	-	1
D.750-L7.87-7D-C	Steel	0.787	0.750	0.787	7.870	4.940	4.400	G1/4	1
G.750-L10.24-10D-E	Carbide	0.787	0.750	0.787	10.240	6.770	7.000	-	1
D1.00-L10.2-7D-C	Steel	0.984	1.000	0.984	10.200	6.830	6.200	G1/4	1
D1.00-L13.21-10D-C	Steel	0.984	1.000	0.984	13.210	8.650	9.200	G1/4	1
D1.25-L12.48-7D-C	Steel	1.260	1.250	1.260	12.480	7.370	7.500	G3/8	1
D1.25-L16.24-10D-C	Steel	1.260	1.250	1.260	16.240	9.670	11.200	G3/8	1
D1.50-L15.26-7D-C	Steel	1.575	1.500	1.575	15.260	9.130	9.200	G1/2	1
D1.50-L19.8-10D-C	Steel	1.575	1.500	1.575	19.800	13.350	13.700	G1/2	1
D2.00-L20.74-7D-C	Steel	1.575	2.000	2.000	20.740	-	12.700	G1/2	2
D2.00-L26.73-10D-C	Steel	1.575	2.000	2.000	26.730	-	18.700	G1/2	2
D2.50-L26.2-7D-C	Steel	1.575	2.500	2.500	26.200	-	16.200	G3/4	2
D2.50-L33.72-10D-C	Steel	1.575	2.500	2.500	33.720	-	23.700	G3/4	2

### SPARE PARTS



Designation	Clamping screw	Wrench
D.625..., G.625...	SRM3X10DIN912	HW2.5
D.750..., G.750...	SRM3.5X10DIN912	HW2.5
D1.00...	SRM4X12DIN912	HW3.0
D1.25...	SRM5X12DIN912	HW4.0
D1.50..., D2.00..., D2.50...	SRM6X16DIN912-12.9	HW5.0

# MEMO

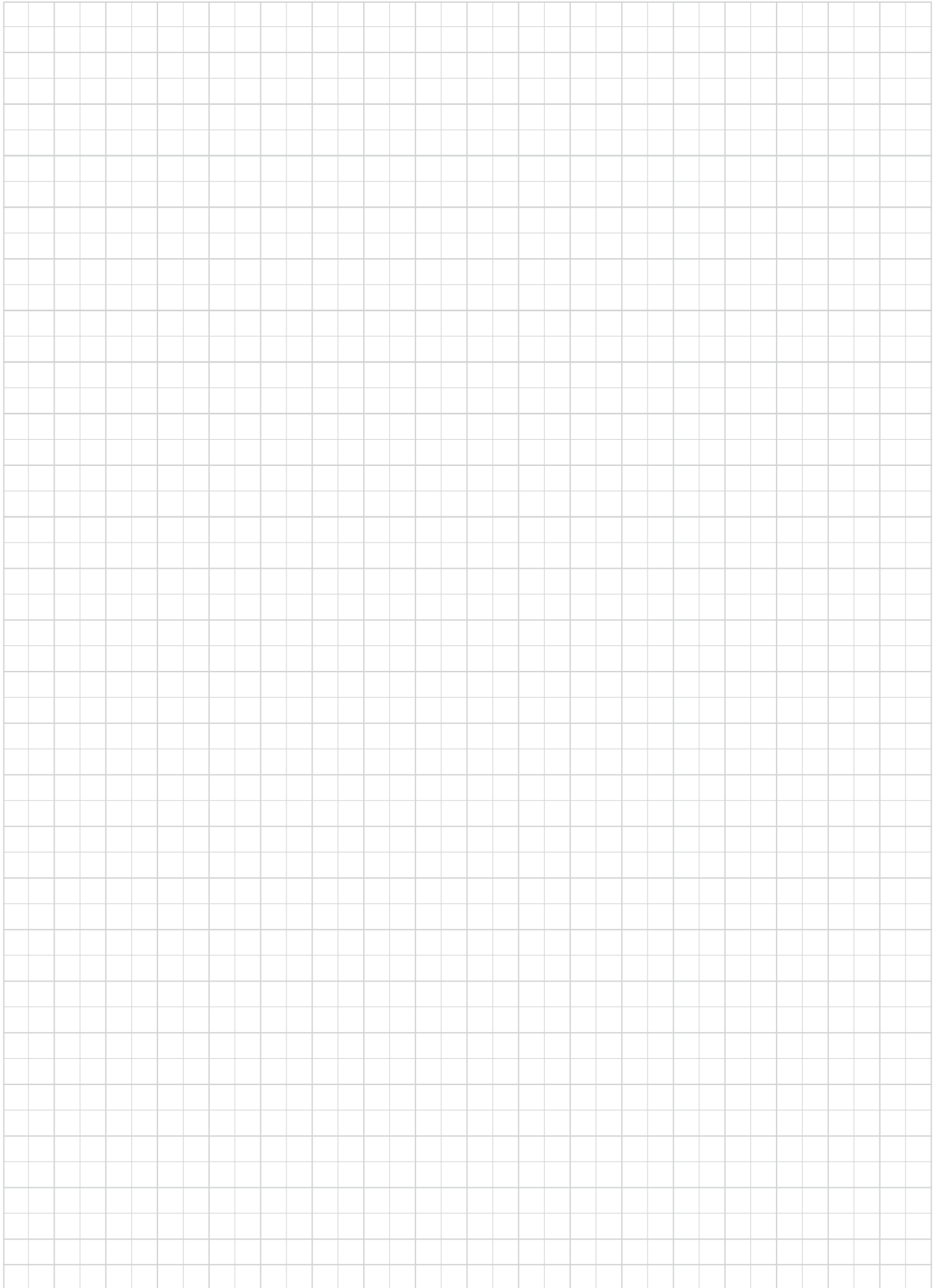
A large grid of graph paper, consisting of 20 columns and 30 rows of small squares, intended for writing a memo. The grid is empty and occupies most of the page.

A large grid of graph paper for taking notes, consisting of 20 columns and 30 rows of small squares.

# Check our site and our App to get more info!



# Tungaloy America, Inc.

3726 N Ventura Drive, Arlington Heights, IL 60004, U.S.A.

Inside Sales: +1-888-554-8394

Technical Support: +1-888-554-8391

Fax: +1-888-554-8392

[www.tungaloy.com/us](http://www.tungaloy.com/us)

## Tungaloy Canada

432 Elgin St. Unit 3, Brantford, Ontario N3S 7P7, Canada

Phone: +1-519-758-5779 Fax: +1-519-758-5791

[www.tungaloy.com/ca](http://www.tungaloy.com/ca)

## Tungaloy de Mexico S.A.

C Los Arellano 113, Parque Industrial Siglo XXI

Aguascalientes, AGS, Mexico 20290

Phone: +52-449-929-5410 Fax: +52-449-929-5411

[www.tungaloy.com/mx](http://www.tungaloy.com/mx)

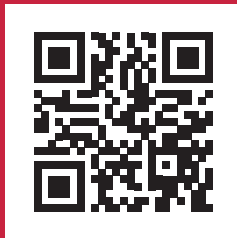

Scan for instant  
web access



[www.tungaloy.com/us](http://www.tungaloy.com/us)

follow us at:

[facebook.com/tungaloyamerica](https://facebook.com/tungaloyamerica)

[twitter.com/tungaloy](https://twitter.com/tungaloy)

[instagram.com/tungaloyamerica](https://instagram.com/tungaloyamerica)

[linkedin.com/company/tungaloy-america](https://linkedin.com/company/tungaloy-america)

To see this product in action visit:

## Tung-TV

[www.youtube.com/tungaloycorporation](http://www.youtube.com/tungaloycorporation)

Distributed by:



FIND US ON THE CLOUD!  
[machingcloud.com](http://machingcloud.com)

