

CONTENTS



General product information

[View](#)

Added products



AVC-SET **-**

Vibration-Free Solution for Deep-Hole Boring Expand [Center height set up device!](#)

[View](#)



C*-SH-D**-*D-CHP, D**-L***-4D-SH

[Expanded steel shanks & PSC adapters for interchangeable boring bar series !!](#)

[View](#)



MiniForce-Turn, TungBoreMini, ISO-EcoTurn, TungThread, TP**

[Expansion of ID boring and threading heads](#)

[View](#)

TurnLine

BOREMEISTER

www.tungaloy.com

Tungaloy Report No. 517-G



Vibration-Free Solution for Deep-Hole Boring

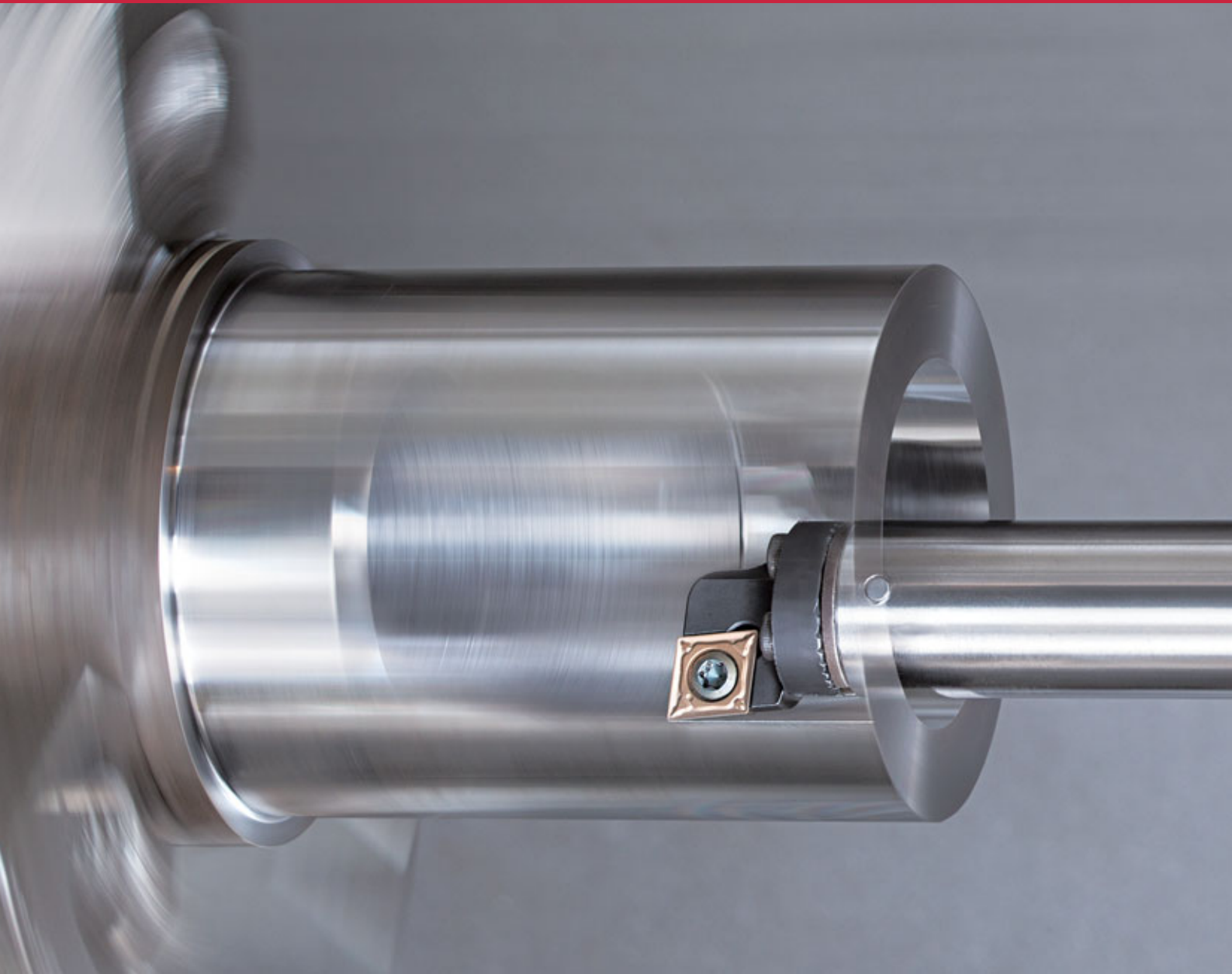

INDUSTRY 4.0
FEED the SPEED!



ACCELERATED MACHINING



TurnLine

BOREMEISTER

TUNGALOY ANTI-VIBRATION TURNING



The ultimate solution for overcoming tool overhang challenges of up to $L/D = 10$

www.tungaloy.com

Unique anti-vibration mechanism in the tool body reduces vibration during deep hole boring with long overhangs of up to **L/D = 10**

- Minimum bore diameter: $\varnothing 20$ mm
- Internal coolant supply improves chip evacuation during deep hole machining
- Various types of cutting heads are available to accommodate different insert shapes

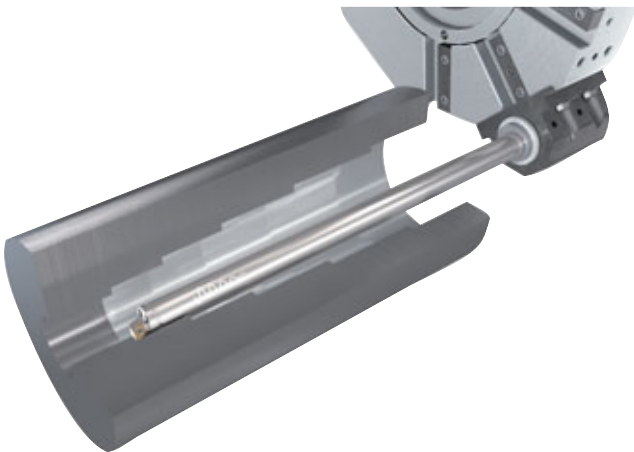

Vibration Dampening Mechanism

When cutting forces create vibration on a boring bar set up with long overhangs, the bar's dampening mechanism counters the tool's motion and cancels the vibration.

The dampening mechanism consists of a weight supported by spring elements.

The vibrations die out quickly eliminating noise and chatter marks.

- Concept image of dampening mechanism

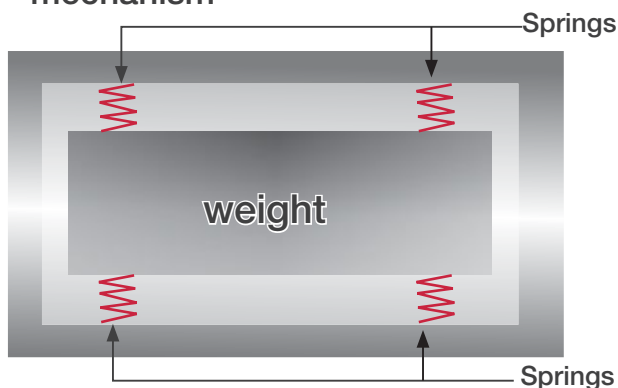

- Tool vibration with and without vibration damper

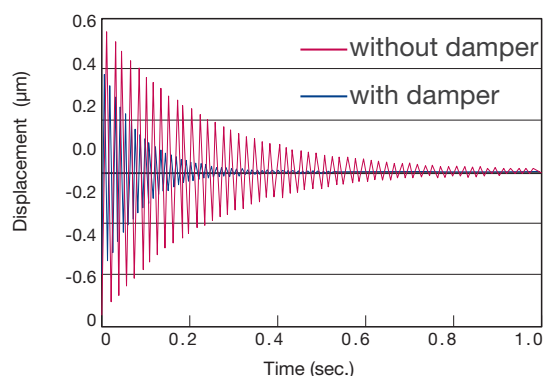

Standard Lineup

BoreMeister anti-vibration bars

L/D	Shank diameter (mm)						
	ø16	ø20	ø25	ø32	ø40	ø50	ø60
7	○	○	○	○	△	△	△
10	●	●	○	○	△	△	△

- : steel shank
- : carbide shank
- △ : on demand

BoreMeister head

Insert shape	Shank diameter (mm)				
	ø16	ø20	ø25	ø32	ø40, ø50, ø60
CCMT	○	○	○	○	△
DCMT	○	○	○	○	△
VCMT		○	○	△	△
DNMG				△	△
VNMG					△

- : standard
- △ : on demand

BoreMeister is comprised of the anti-vibration bar and interchangeable boring head, featuring serrated interfaces for high precision indexing. They are connected by screws, allowing the fitting of a wide range of cutting heads for increased flexibility.

Anti vibration bar

Boring head

Serration

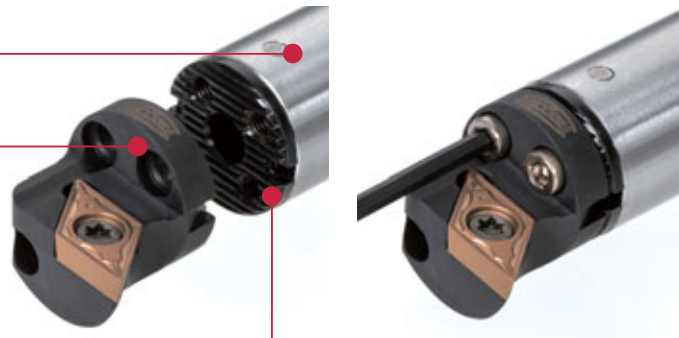

Boring bar selection guide

For machining of long overhangs over $5xL/D$, the use of an anti-vibration bar is highly effective.

Tool selection according to length-to-diameter ratio

Steel shank	Carbide reinforced	Carbide shank	BoreMeister
$L/D \leq 3$	$L/D \leq 4$	$L/D \leq 5$	$L/D \leq 10$

For custom tooling inquiries, contact Tungaloy



General use recommendations

1. Machine clamping recommendation

For BoreMeister to maximize its vibration dampening capability, clamping stability is extremely important. When clamping the cylindrical boring bar, Tungaloy recommends the use of a split sleeve holders, which encompass the tool shank, securing maximum contact area. Never use a conventional screw clamp method as it may damage the tool and will not properly prevent vibration.

Clamping method

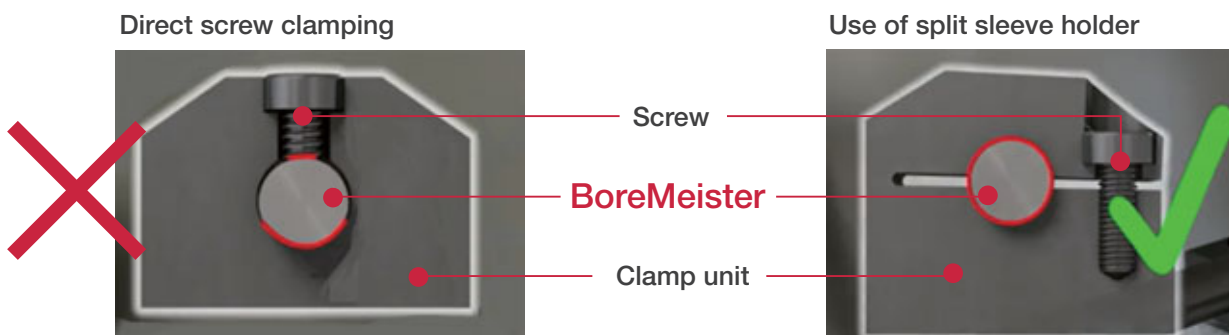

For custom tooling inquiries, contact Tungaloy.

Clamping length of BoreMeister should be $L/D = 4$ or more.

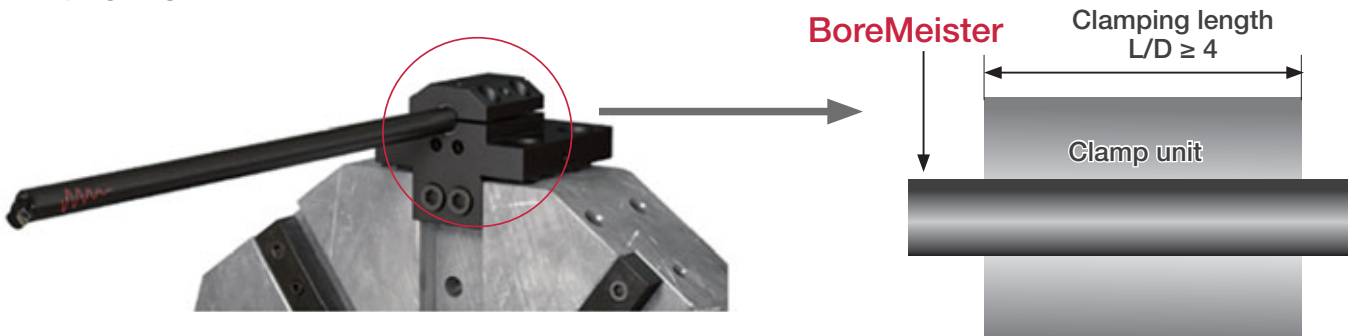

2. Center height positioning

Precise center height positioning is another important factor to achieve the right dimensional tolerances and surface finish. BoreMeister has no flats on its cylindrical shank to secure the tool center. Use a dial gauge to properly adjust the tool center height while fine-sliding the boring head on the serrated interface.

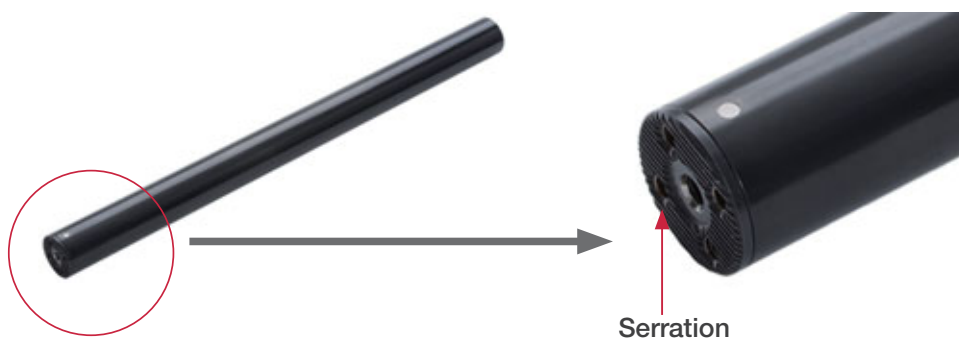

S-SCLCR/L-H

Screw-on clamp interchangeable boring heads for positive 80° rhombic inserts

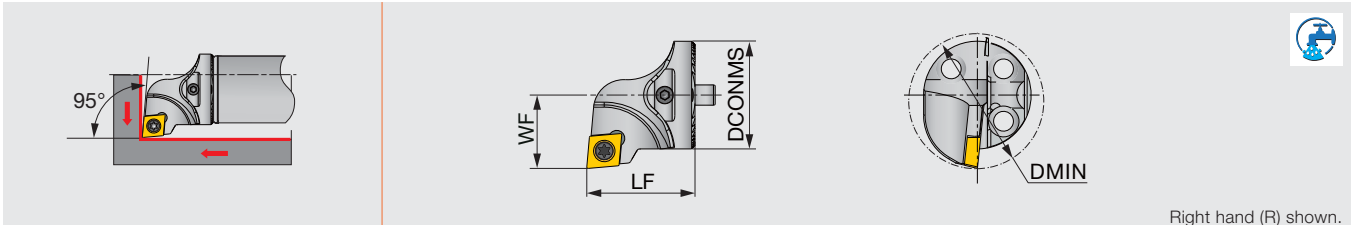

Right hand (R) shown.

Designation	DMIN	DCONMS	WF	LF	Shank size	Insert
S16-SCLCR/L06-H	20	16	11	20	D/G16	CC**0602...
S20-SCLCR/L09-H	25	20	13	20	D/G20	CC**09T3...
S25-SCLCR/L09-H	32	25	17	22	D25	CC**09T3...
S32-SCLCR/L09-H	40	30	22	32	D32	CC**09T3...
S40-SCLCR/L12T-H	50	40	27	38	D40, D50, D60	CC**1204...

Note: When using a right or left hand insert, the right hand insert (R) is used for the left hand toolholders (SCLCL** type), and the left hand insert (L) is used for the right hand toolholders (SCLCR** type).

SPARE PARTS



Designation	Clamping screw	Wrench	Shim	Shim screw
S16-SCLCR/L06-H	SR14-548	T-7/5	-	-
S20-SCLCR/L09-H	SR16-236	T-15/5	-	-
S25-SCLCR/L09-H	SR16-236	T-15/5	-	-
S32-SCLCR/L09-H	SR16-236	T-15/5	-	-
S40-SCLCR/L12T-H	SR16-212	T-20/5	TCC4-2	SRTC-4

S-SDUCR/L-H

Screw-on clamp interchangeable boring heads for positive 55° rhombic inserts

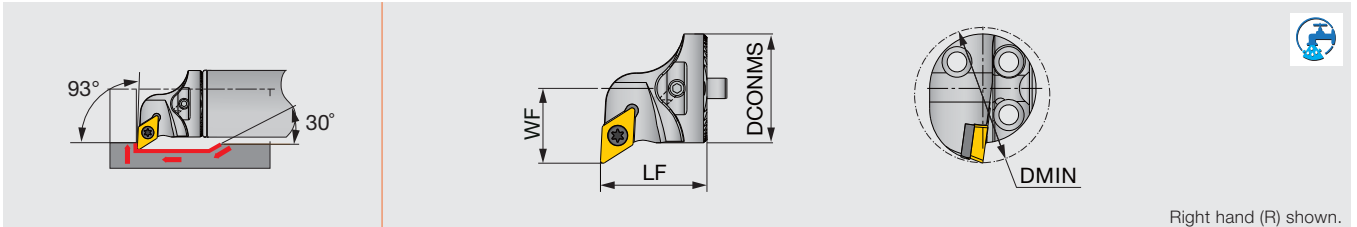

Designation	DMIN	DCONMS	WF	LF	Shank size	Insert
S16-SDUCR/L07-H	20	16	11	20	D/G16	DC**0702...
S20-SDUCR/L11-H	25	20	13	20	D/G20	DC**11T3...
S25-SDUCR/L11-H	32	25	17	20	D25	DC**11T3...
S32-SDUCR/L11T-H	40	32	22	32	D32	DC**11T3...
S40-SDUCR/L11T-H	50	40	27	32	D40, D50, D60	DC**11T3...

Note: When using a right or left hand insert, the right hand insert (R) is used for the left hand toolholders (SDUCL** type), and the left hand insert (L) is used for the right hand toolholders (SDUCR** type).

SPARE PARTS

Designation	Clamping screw	Wrench	Shim	Shim screw
S16-SDUCR/L07-H	SR14-548	T-7/5	-	-
S20-SDUCR/L11-H	SR16-236P	T-15/5	-	-
S25-SDUCR/L11-H	SR16-236P	T-15/5	-	-
S32-SDUCR/L11T-H	SR16-236P	T-15/5	TDC3-1P	SRTC-3P
S40-SDUCR/L11T-H	SR16-236P	T-15/5	TDC3-1P	SRTC-3P

S-SVUCR/L-H

Screw-on clamp interchangeable boring heads for positive 35° rhombic inserts

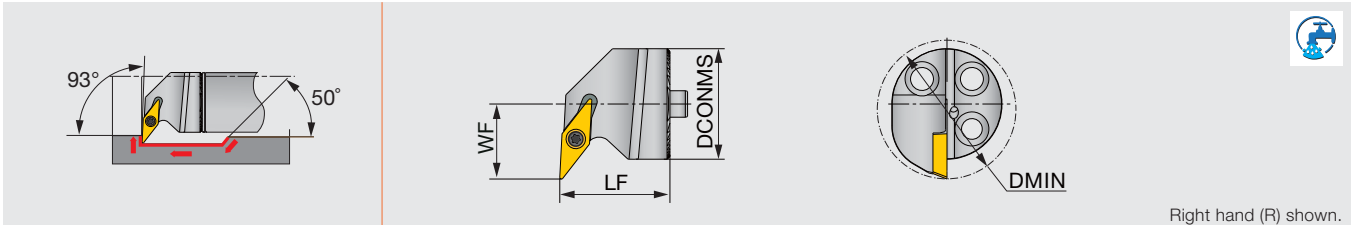

Right hand (R) shown.

Designation	DMIN	DCONMS	WF	LF	Shank size	Insert
S20-SVUCR/L11-H	27	20	16	20	D/G20	VC**1103...
S25-SVUCR/L11-H	31	25	17	25	D25	VC**1103...

Note: When using a right or left hand insert, the right hand insert (R) is used for the left hand toolholders (SVUCL** type), and the left hand insert (L) is used for the right hand toolholders (SVUCR** type).

SPARE PARTS



Designation	Clamping screw	Wrench
S20-SVUCR/L11-H	SR14-560	T-8/5
S25-SVUCR/L11-H	SR14-560	T-8/5

S-SVLCR/L-H

Screw-on clamp interchangeable boring heads for positive 35° rhombic inserts

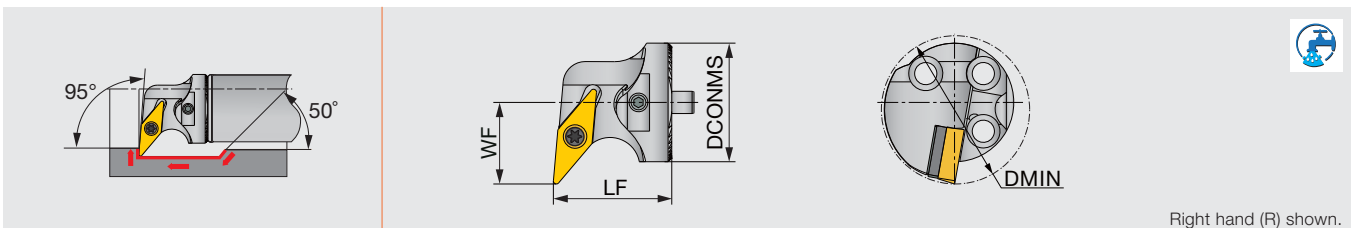

Right hand (R) shown.

Designation	DMIN	DCONMS	WF	LF	Shank size	Insert
S32-SVLCR/L16T-H	40	32	22	32	D32	VC**1604...
S40-SVLCR/L16T-H	50	40	27	32	D40, D50, D60	VC**1604...

Note: When using a right or left hand insert, the right hand insert (R) is used for the left hand toolholders (SVLCL** type), and the left hand insert (L) is used for the right hand toolholders (SVLCR** type).

SPARE PARTS



Designation	Clamping screw	Wrench	Shim	Shim screw
S32-SVLCR/L16T-H	SR16-236P	T-15/5	TVC 3-1P	SRTC-3P
S40-SVLCR/L16T-H	SR16-236P	T-15/5	TVC 3-1P	SRTC-3P

S-DDUNR/L-H

Double clamp interchangeable boring heads for negative 55° rhombic inserts

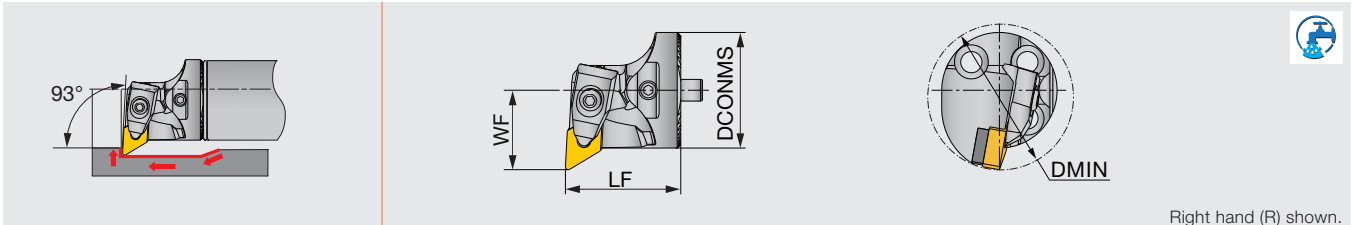

Right hand (R) shown.

Designation	DMIN	DCONMS	WF	LF	Shank size	Insert
S32-DDUNR/L11T-H	40	32	22	32	D32	DN**1104...
S40-DDUNR/L15T-H	50	40	27	32	D40, D50, D60	DN**1504/06...

Note: When using a right or left hand insert, the right hand insert (R) is used for the left hand toolholders (DDUNL** type), and the left hand insert (L) is used for the right hand toolholders (DDUNR** type).

SPARE PARTS

Designation	Shim	Shim screw	Clamp	Clamping screw	Spring	Wrench
S32-DDUNR/L11T-H	RDT3-2	SR40085I	LCGR-3	SRRC3	KSP3	HW2.5
S40-DDUNR/L15T-H	RDT433	SR14-506	DLM4	DLS4	DSP4	HW3.0
S40-DDUNR/L15T-H	RDT443	SR14-506	DLM4	DLS4	DSP4	HW3.0

S-DVUNR/L-H

Double clamp interchangeable boring heads for negative 35° rhombic inserts

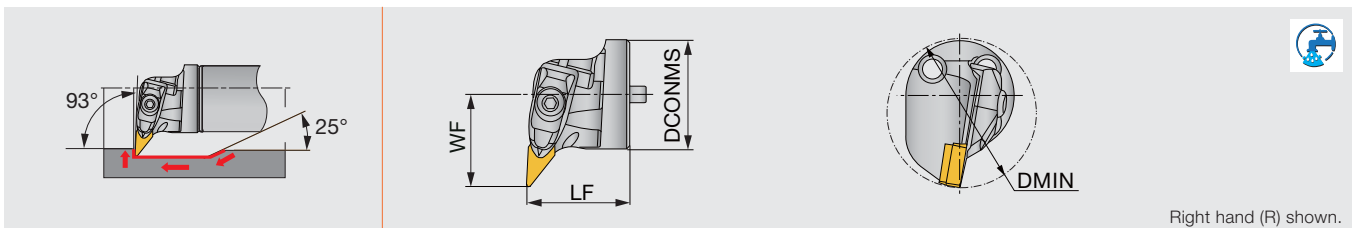

Right hand (R) shown.

Designation	DMIN	DCONMS	WF	LF	Shank size	Insert
S40-DVUNR/L16T-H	56	40	34	38	D40, D50, D60	VN**1604...

SPARE PARTS

Designation	Shim	Shim screw	Clamp	Clamping screw	Spring	Wrench
S40-DVUNR/L16T-H	ASV322	SR35080I	DLM3V	SR10402267	KSP5	HW4.0

Straight Shank

Anti-vibration bars with through coolant for interchangeable turning heads

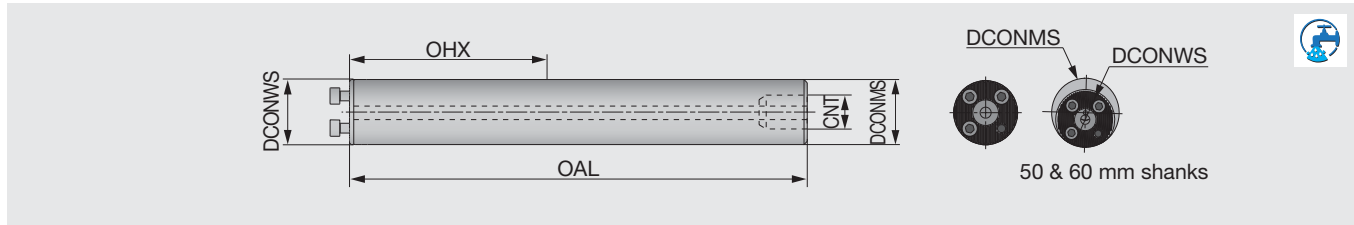

Designation	Material	DCONWS	DCONMS	OAL	OHX	CNT
D16-L156-7D-C	Steel	16	16	156.3	92	G1/8
G16-L204-10D-E	Carbide	16	16	204.3	140	-
D20-L200-7D-C	Steel	20	20	200.3	120	G1/4
G20-L260-10D-E	Carbide	20	20	260.3	180	-
D25-L255-7D-C	Steel	25	25	257.5	155	G1/4
D25-L330-10D-C	Steel	25	25	332.5	230	G1/4
D32-L320-7D-C	Steel	32	32	323	192	G3/8
D32-L416-10D-C	Steel	32	32	419	288	G3/8
D40-L408-7D-C	Steel	40	40	411	248	G1/2
D40-L528-10D-C	Steel	40	40	531	368	G1/2
D50-L518-7D-C	Steel	40	50	523	318	G1/2
D50-L668-10D-C	Steel	40	50	673	468	G1/2
D60-L628-7D-C	Steel	40	60	633	388	G3/4
D60-L808-10D-C	Steel	40	60	813	568	G3/4

SPARE PARTS



Designation	Clamping screw	Wrench
D16-L..., G16-L...	SRM3X10DIN912	HW2.5
D20-L..., G20-L...	SRM3.5X10DIN912	HW2.5
D25-L...	SRM4X12DIN912	HW3.0
D32-L...	SRM5X12DIN912	HW4.0
D40-L..., D50-L..., D60-L...	SRM6X16DIN912-12.9	HW5.0

AVC-SET

Center height set up device

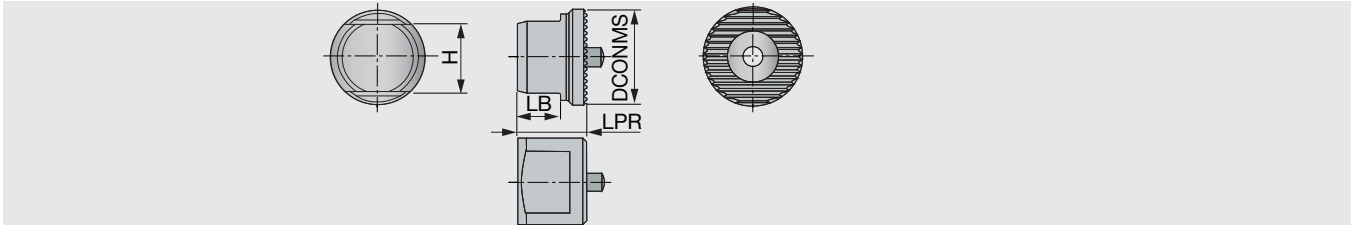

Designation	DCONMS	H	LPR	LB	Applicable shank
AVC-SET 16-25	20	15	14.5	8.9	16, 20, 25
AVC-SET 32-60	29	16	17.5	11.43	32, 40, 50, 60

MEMO

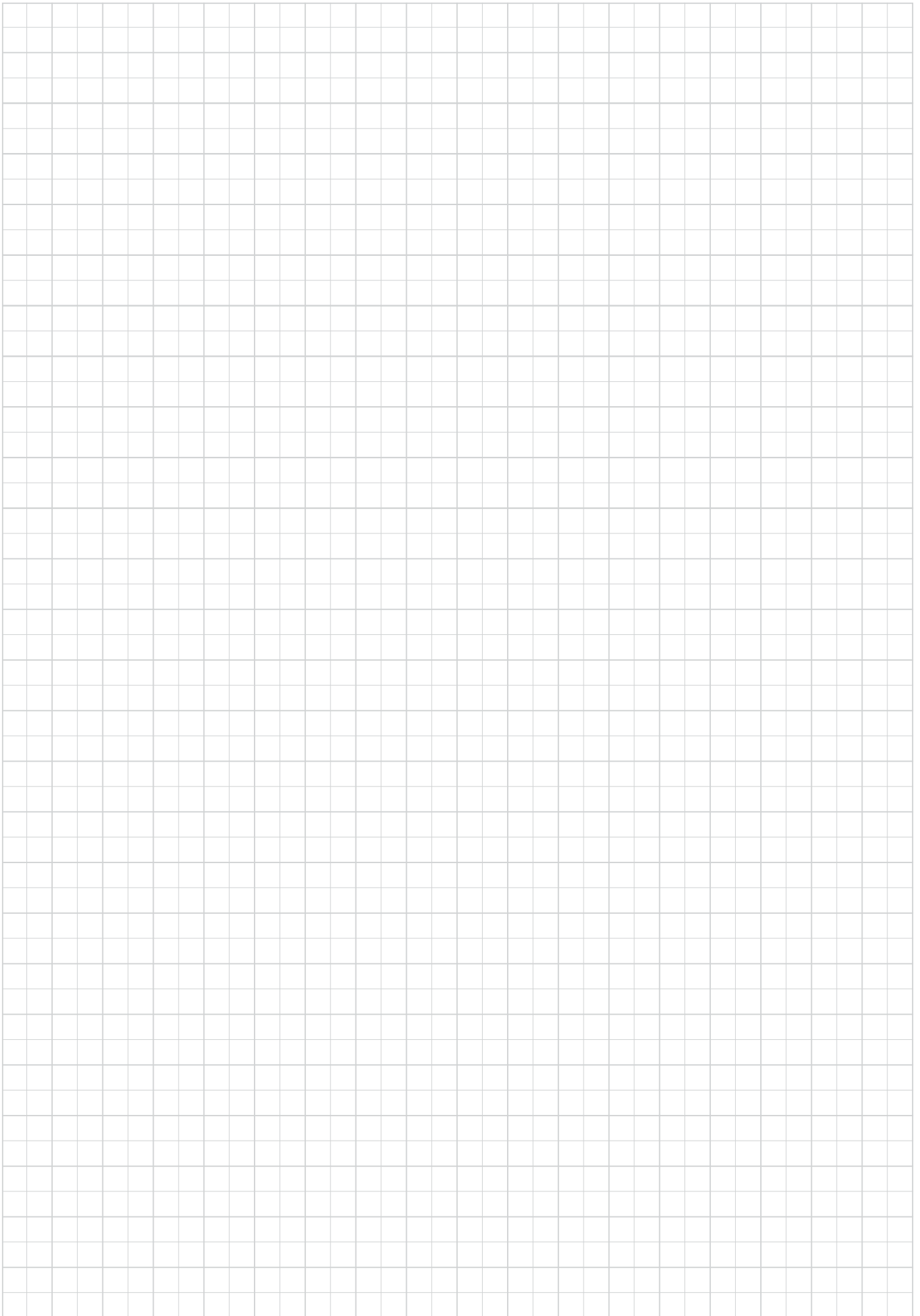
A large grid of graph paper for taking notes, consisting of 20 columns and 30 rows of small squares.

Check our site and our App to get more info!

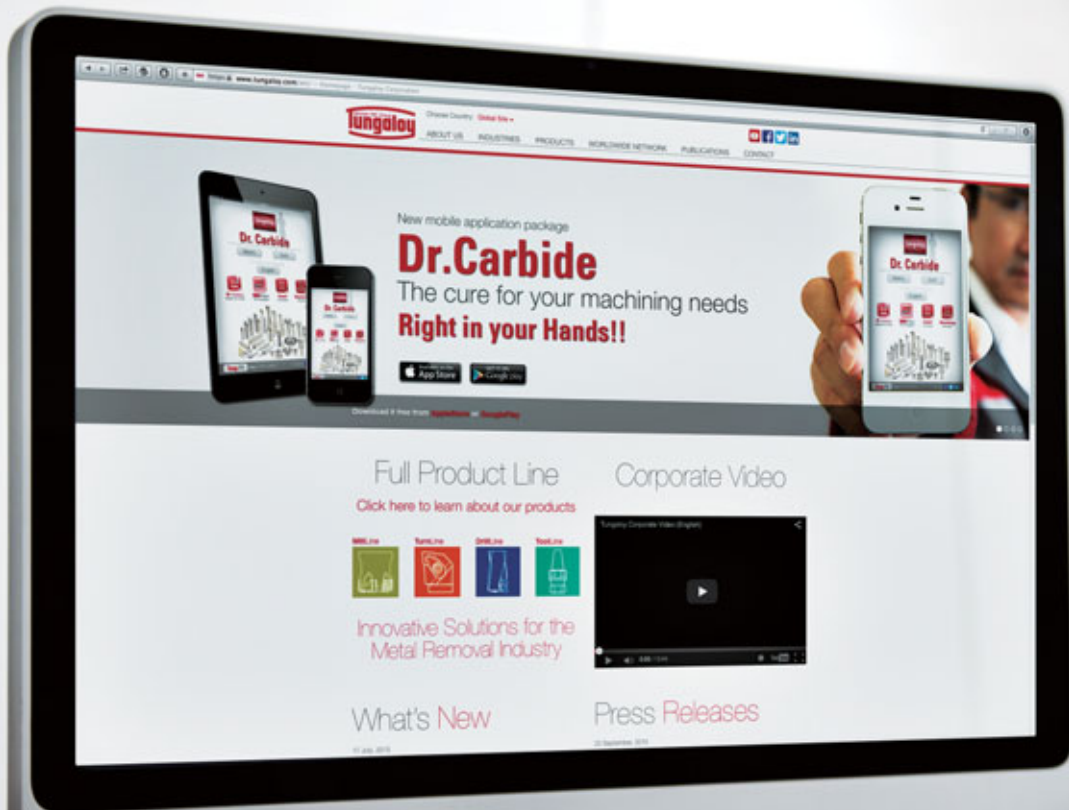

Full Product Line

Click here to learn about our products



Innovative Solutions for the Metal Removal Industry

Corporate Video



What's New

Press Releases



Available on the App Store



GET IT ON Google play

Tungaloy Corporation (Head office)

11-1 Yoshima-Kogyodanchi
Iwaki-city, Fukushima, 970-1144 Japan
Phone: +81-246-36-8501
Fax: +81-246-36-8542
www.tungaloy.co.jp

Tungaloy America, Inc.

3726 N Ventura Drive
Arlington Heights, IL 60004, U.S.A.
Phone: +1-888-554-8394
Fax: +1-888-554-8392
www.tungaloyamerica.com

Tungaloy Canada

432 Elgin St. Unit 3
Brantford, Ontario N3S 7P7, Canada
Phone: +1-519-758-5779
Fax: +1-519-758-5791
www.tungaloy.com/ca

Tungaloy de Mexico S.A.

C Los Arellano 113,
Parque Industrial Siglo XXI
Aguascalientes, AGS, Mexico 20290
Phone: +52-449-929-5410
Fax: +52-449-929-5411
www.tungaloy.com/mx

Tungaloy do Brasil Ltda.

Avd. Independencia N4158 Residencial Flora
13280-000 Vinhedo, São Paulo, Brasil
Phone: +55-19-38262757
Fax: +55-19-38262757
www.tungaloy.com/br

Tungaloy Germany GmbH

An der Alten Ziegelei 1
D-40789 Monheim, Germany
Phone: +49-2173-90420-0
Fax: +49-2173-90420-19
www.tungaloy.de

Tungaloy France S.A.S.

ZA Courtaboeuf - Le Rio
1 rue de la Terre de feu
F-91952 Courtaboeuf Cedex, France
Phone: +33-1-6486-4300
Fax: +33-1-6907-7817
www.tungaloy.fr

Tungaloy Italia S.r.l.

Via E. Andolfato 10
I-20126 Milano, Italy
Phone: +39-02-252012-1
Fax: +39-02-252012-65
www.tungaloy.it

Tungaloy Czech s.r.o.

Turanka 115
CZ-627 00 Brno, Czech Republic
Phone: +420-532 123 391
Fax: +420-532 123 392
www.tungaloy.cz

Tungaloy Ibérica S.L.

C/Miquel Servet, 43B, Nau 7
Pol. Ind. Bufalvent
ES-08243 Manresa (BCN), Spain
Phone: +34 93 113 1360
Fax: +34 93 876 2798
www.tungaloy.es

Tungaloy Scandinavia AB

Bultgatan 38
442 40 Kungälv, Sweden
Phone: +46-462119200
www.tungaloy.se

Tungaloy Rus, LLC

115432, Moscow, Andropov Avenue, 18,
building 7, 11th floor (office 3). Metro station
"Technopark". Business center «I-Land».
Phone: +7-499-683-01-80/81
www.tungaloy.com/ru

Tungaloy Polska Sp. z o.o.

ul. Genewska 24
03-963 Warszawa, Poland
Phone: +48-22-617-0890
Fax: +48-22-617-0890
www.tungaloy.com/pl

Tungaloy U.K. Ltd

The Technology Centre,
Wolverhampton Science Park
Glaisher Drive, Wolverhampton
West Midlands WV10 9RU, UK
Phone: +44 121 4000 231
Fax: +44 121 270 9694
www.tungaloy.com/uk
salesinfo@tungaloyuk.co.uk

Tungaloy Hungary Kft

Erzsébet királyné útja 125
H-1142 Budapest, Hungary
Phone: +36 1 781-6846
Fax: +36 1 781-6866
www.tungaloy.com/hu
info@tungaloytools.hu

Tungaloy Turkey

Dudullu OSB 4. Cad No:4
34776 Umraniye Istanbul, TURKEY
Phone: +90 216 540 04 67
Fax: +90 216 540 04 87
www.tungaloy.com.tr
info@tungaloy.com.tr

Tungaloy Benelux b.v.

Tjalk 70
NL-2411 NZ Bodegraven, Netherlands
Phone: +31 172 630 420
Fax: +31 172 630 429
www.tungaloy-benelux.com

Tungaloy Croatia

Ulica bana Josipa Jelačića 87,
10430 Samobor
Phone: +385 1 3326 604
Fax: +385 1 3327 683
www.tungaloy.hr

Tungaloy Cutting Tool (Shanghai) Co.,Ltd.

Rm No 401 No.88 Zhabei
Jiangchang No.3 Rd
Shanghai 200436, China
Phone: +86-21-3632-1880
Fax: +86-21-3621-1918
www.tungaloy.com/cn

Tungaloy Cutting Tool (Thailand) Co.,Ltd.

Interlink tower 4th Fl.
1858/5-7 Bangna-Trad Road
km.5 Bangna, Bangna, Bangkok 10260
Thailand
Phone: +66-2-751-5711
Fax: +66-2-751-5715
www.tungaloy.co.th

Tungaloy Singapore (Pte.), Ltd.

62 Ubi Road 1, #06-11 Oxley BizHub 2
Singapore 408734
Phone: +65-6391-1833
Fax: +65-6299-4557
www.tungaloy.com/sg

Tungaloy Vietnam

LE 04-38, Lexington Residence
67 Mai Chi Tho, Dist. 2,
Ho Chi Minh City, Vietnam
Phone: +84-8-37406660
Fax: +84-8-37406662
www.tungaloy.com/sg

Tungaloy India Pvt. Ltd.

Indiabulls Finance Centre,
Unit # 902-A, 9th Floor,
Tower 1, Senapati Bapat Marg,
Elphinstone Road (West),
Mumbai-400013, India
Phone: +91-22-6124-8804
Fax: +91-22-6124-8899
www.tungaloy.com/in

Tungaloy Korea Co., Ltd

#1312, Byucksan Digital Valley 5-cha
Beotkkot-ro 244, Geumcheon-gu
153-788 Seoul, Korea
Phone: +82-2-2621-6161
Fax: +82-2-6393-8952
www.tungaloy.com/kr

Tungaloy Malaysia Sdn Bhd

50 K-2, Kelana Mall, Jalan SS6/14
Kelana Jaya, 47301
Petaling Jaya, Selangor Darul Ehsan
Malaysia
Phone: +603-7805-3222
Fax: +603-7804-8563
www.tungaloy.com/my

Tungaloy Australia Pty Ltd

PO Box 2232, 68/1470
Ferntree Gully Road, Knoxfield
Victoria 3180, Australia
Phone: +61-3-9755-8147
Fax: +61-3-9755-6070
www.tungaloy.com.au

PT. Tungaloy Indonesia

Kompleks Grand Wisata Block AA-10 No.3-5
Cibitung
Bekasi 17510, Indonesia
Phone: +62-21-8261-5808
Fax: +62-21-8261-5809
www.tungaloy.com/id



www.tungaloy.com

follow us at:

facebook.com/tungaloyjapan

twitter.com/tungaloyjapan

To see this product in action visit:

Tung-TV

www.youtube.com/tungaloycorporation

Distributed by:



DOWNLOAD
Dr. Carbide App



FIND US ON THE CLOUD!
machiningcloud.com



Available on the
App Store



GET IT ON
Google play



AS9100 Certified
78006
2015.11.04
ISO14001 Certified
EC97J1123
1997.11.26

TurnLine

BOREMEISTER

www.tungaloy.com

Tungaloy Report No. 517S1-G



Vibration-Free Solution for Deep-Hole Boring
Expand **Center height set up device!**

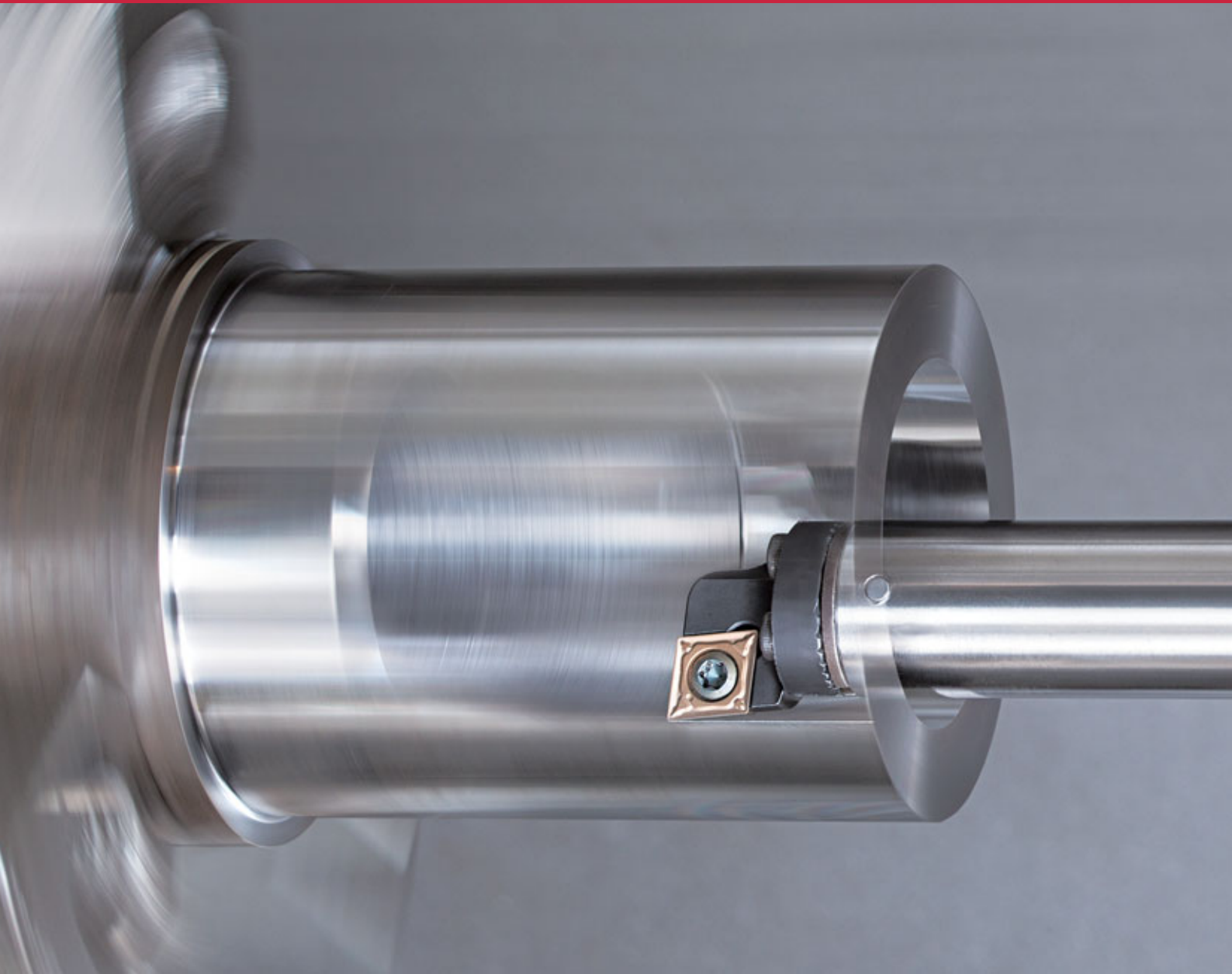

INDUSTRY 4.0
FEED the SPEED!



The ultimate solution for overcoming tool overhang challenges of up to $L/D = 10$

Center height positioning

Precise center height positioning is another important factor to achieve the right dimensional tolerances and surface finish. BoreMeister has no flats on its cylindrical shank to secure the tool center. Use a center height device and dial gauge to properly adjust the tool center height. Serrated head with magnetic core ensures fixed position of the head on the shank without screws.

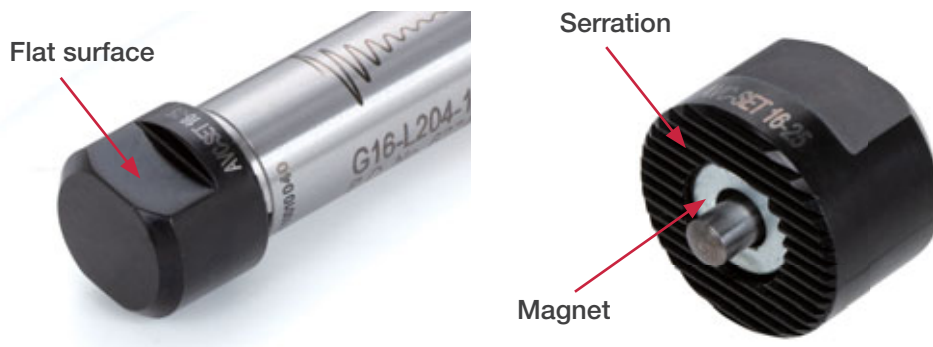

AVC-SET

Center height set up device

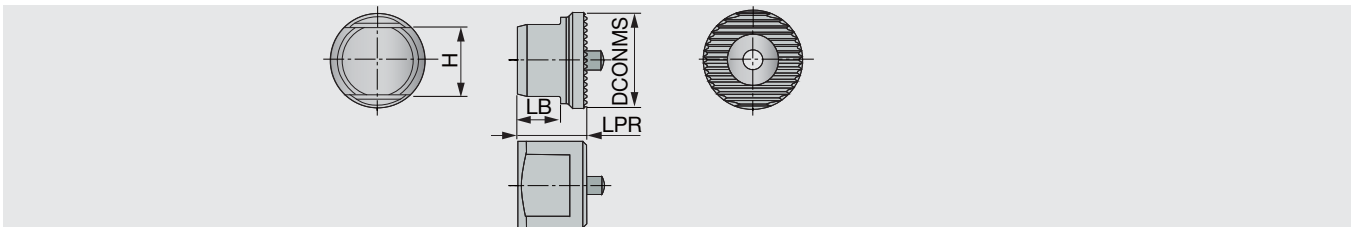

Designation	DCONMS	H	LPR	LB	Applicable shank
AVC-SET 16-25	20	15	14.5	8.9	16, 20, 25
AVC-SET 32-60	29	16	17.5	11.43	32, 40, 50, 60

Tungaloy Corporation (Head office)

11-1 Yoshima-Kogyodanchi
Iwaki-city, Fukushima 970-1144 Japan
Phone: +81-246-36-8501
Fax: +81-246-36-8542
www.tungaloy.co.jp

Tungaloy America, Inc.

3726 N Ventura Drive
Arlington Heights, IL 60004, U.S.A.
Phone: +1-888-554-8394
Fax: +1-888-554-8392
www.tungaloy.com/us

Tungaloy Canada

432 Elgin St. Unit 3
Brantford, Ontario N3S 7P7, Canada
Phone: +1-519-758-5779
Fax: +1-519-758-5791
www.tungaloy.com/ca

Tungaloy de Mexico S.A.

C Los Arellano 113,
Parque Industrial Siglo XXI
Aguascalientes, AGS, Mexico 20290
Phone: +52-449-929-5410
Fax: +52-449-929-5411
www.tungaloy.com/mx

Tungaloy do Brasil Ltda.

Avd. Independencia N4158 Residencial Flora
13280-000 Vinhedo, São Paulo, Brasil
Phone: +55-19-38262757
Fax: +55-19-38262757
www.tungaloy.com/br

Tungaloy Germany GmbH

An der Alten Ziegelei 1
D-40789 Monheim, Germany
Phone: +49-2173-90420-0
Fax: +49-2173-90420-19
www.tungaloy.com/de

Tungaloy France S.A.S.

ZA Courtaboef - Le Rio
1 rue de la Terre de feu
F-91952 Courtaboef Cedex, France
Phone: +33-1-6486-4300
Fax: +33-1-6907-7817
www.tungaloy.com/fr

Tungaloy Italia S.r.l.

Via E. Andolfato 10
I-20126 Milano, Italy
Phone: +39-02-252012-1
Fax: +39-02-252012-65
www.tungaloy.com/it

Tungaloy Czech s.r.o.

Turanka 115
CZ-627 00 Brno, Czech Republic
Phone: +420-532 123 391
Fax: +420-532 123 392
www.tungaloy.com/cz

Tungaloy Ibérica S.L.

C/Miquel Servet, 43B, Nau 7
Pol. Ind. Bufalvent
ES-08243 Manresa (BCN), Spain
Phone: +34 93 113 1360
Fax: +34 93 876 2798
www.tungaloy.com/es

Tungaloy Scandinavia AB

Bultgatan 38
442 40 Kungälv, Sweden
Phone: +46-462119200
Fax: +46-462119207
www.tungaloy.com/se

Tungaloy Rus, LLC

Andropova avenue, h.18/7,
11 floor, office 3, 115432,
Moscow, Russia
Phone: +7-499-683-01-80
Fax: +7-499-683-01-81
www.tungaloy.com/ru

Tungaloy Polska Sp. z o.o.

Ul. Irysowa 1, 55-040 Bielany
Wroclawskie, Poland
Phone: +48 607 907 237
www.tungaloy.com/pl

Tungaloy U.K. Ltd

Gallan Park, Watling Street,
Cannock, WS110XG, UK
Phone: +44 121 4000 231
Fax: +44 121 270 9694
www.tungaloy.com/uk

Tungaloy Hungary Kft

Erzsébet királyné útja 125
H-1142 Budapest, Hungary
Phone: +36 1 781-6846
Fax: +36 1 781-6866
www.tungaloy.com/hu

Tungaloy Turkey

Serifali Mah.bayraktar Bulvari Kule Sk. No:26
34775 Umraniye / Istanbul / Turkey
Phone: +90 216 540 04 67
Fax: +90 216 540 04 87
www.tungaloy.com/tr

Tungaloy Benelux b.v.

Tjalk 70
NL-2411 NZ Bodegraven, Netherlands
Phone: +31 172 630 420
Fax: +31 172 630 429
www.tungaloy.com/nl

Tungaloy Croatia

Ulica bana Josipa Jelačića 87,
10430, Samobor, Croatia
Phone: +385 1 3326 604
Fax: +385 1 3327 683
www.tungaloy.com/hr

Tungaloy Cutting Tool (Shanghai) Co.,Ltd.

Rm No 401 No.88 Zhabei
Jiangchang No.3 Rd
Shanghai 200436, China
Phone: +86-21-3632-1880
Fax: +86-21-3621-1918
www.tungaloy.com/cn

Tungaloy Cutting Tools (Taiwan) Co.,Ltd.

9F, No.293, Zhongyang Rd,
Xinzhuang Dist, New Taipei City,
24251 Taiwan
Phone: +886-2-8521-9986
Fax: +886-2-8521-8935
www.tungaloy.com/tw

Tungaloy Cutting Tools (Thailand) Co.,Ltd.

Interlink tower 4th Fl.
1858/5-7 Bangna-Trad Road
km.5 Bangna, Bangna, Bangkok 10260
Thailand
Phone: +66-2-751-5711
Fax: +66-2-751-5715
www.tungaloy.com/th

Tungaloy Singapore (Pte.), Ltd.

62 Ubi Road 1, #06-11 Oxley BizHub 2
Singapore 408734
Phone: +65-6391-1833
Fax: +65-6299-4557
www.tungaloy.com/sg

Tungaloy Vietnam

LE04.38, Lexington Residence
67 Mai Chi Tho St., Dist. 2,
Ho Chi Minh City, Vietnam
Phone: +84-2837406660
www.tungaloy.com/sg

Tungaloy India Pvt. Ltd.

Indiabulls Finance Centre,
Unit # 902-A, 9th Floor,
Tower 1, Senapati Bapat Marg,
Elphinstone Road (West),
Mumbai-400013, India
Phone: +91-22-6124-8804
Fax: +91-22-6124-8899
www.tungaloy.com/in

Tungaloy Korea Co., Ltd

#1312, Byucksan Digital Valley 5-cha
Beotkkot-ro 244, Geumcheon-gu
153-788 Seoul, Korea
Phone: +82-2-2621-6161
Fax: +82-2-6393-8952
www.tungaloy.com/kr

Tungaloy Malaysia Sdn Bhd

50 K-2, Kelana Mall, Jalan SS6/14
Kelana Jaya, 47301
Petaling Jaya, Selangor Darul Ehsan
Malaysia
Phone: +603-7805-3222
Fax: +603-7804-8563
www.tungaloy.com/my

Tungaloy Australia Pty Ltd

Unit 68 1470 Ferntree Gully Road
Knoxfield 3180 Victoria, Australia
Phone: +61-3-9755-8147
Fax: +61-3-9755-6070
www.tungaloy.com/au

PT. Tungaloy Indonesia

Kompleks Grand Wisata Block AA-10 No.3-5
Cibitung
Bekasi 17510, Indonesia
Phone: +62-21-8261-5808
Fax: +62-21-8261-5809
www.tungaloy.com/id



www.tungaloy.com

follow us at:

facebook.com/tungaloyjapan
twitter.com/tungaloyjapan
www.youtube.com/tungaloycorporation



AS9100 Certified
78006
2015.11.04
ISO14001 Certified
EC97J1123
1997.11.26

Distributed by:



FIND US ON THE CLOUD!
machiningcloud.com



BOREMEISTER

Tungaloy Report No. 517S2-G

Expanded steel shanks & PSC adapters
for interchangeable boring bar series !!

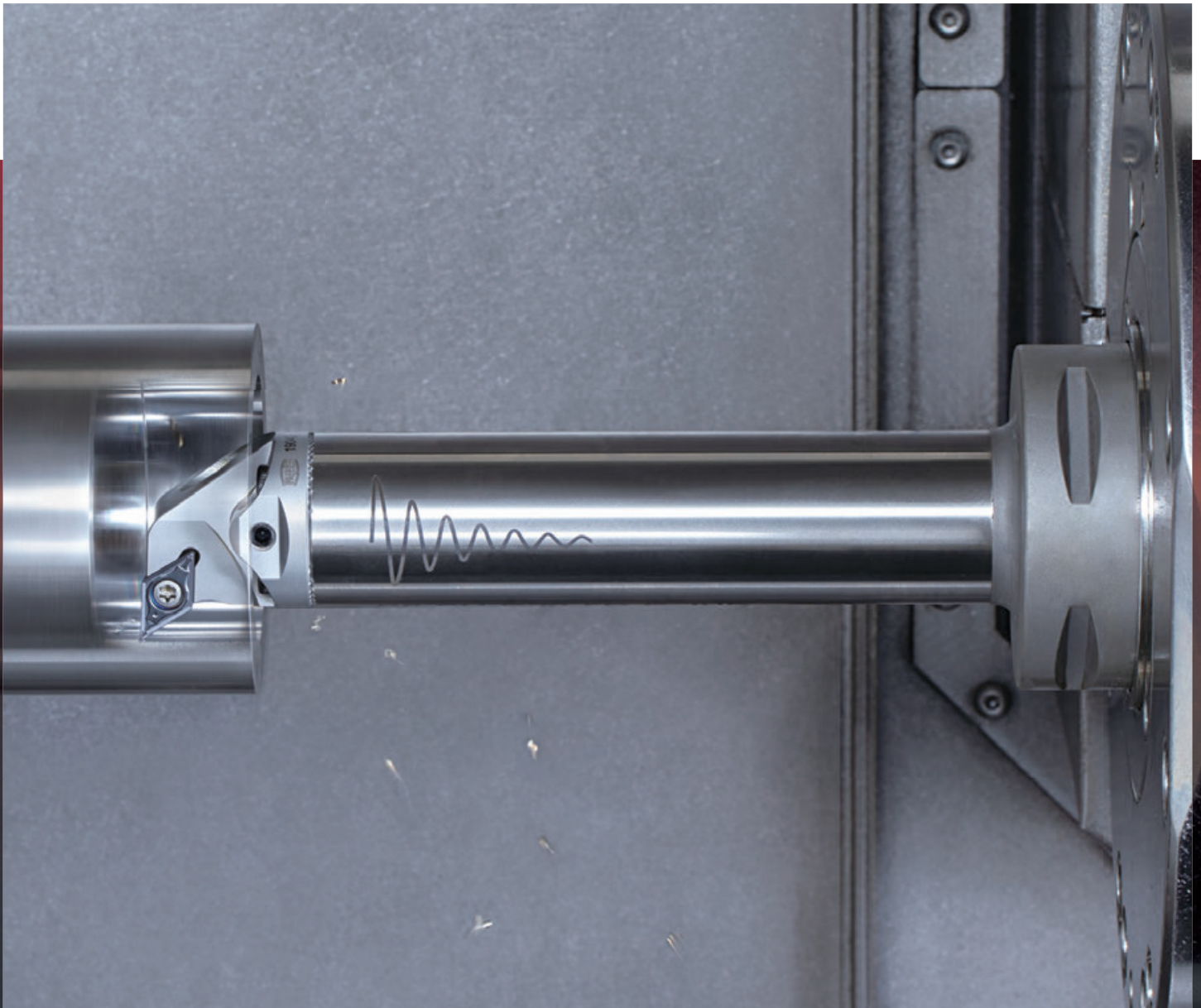



For more information

Expanded lineup for various ID boring applications

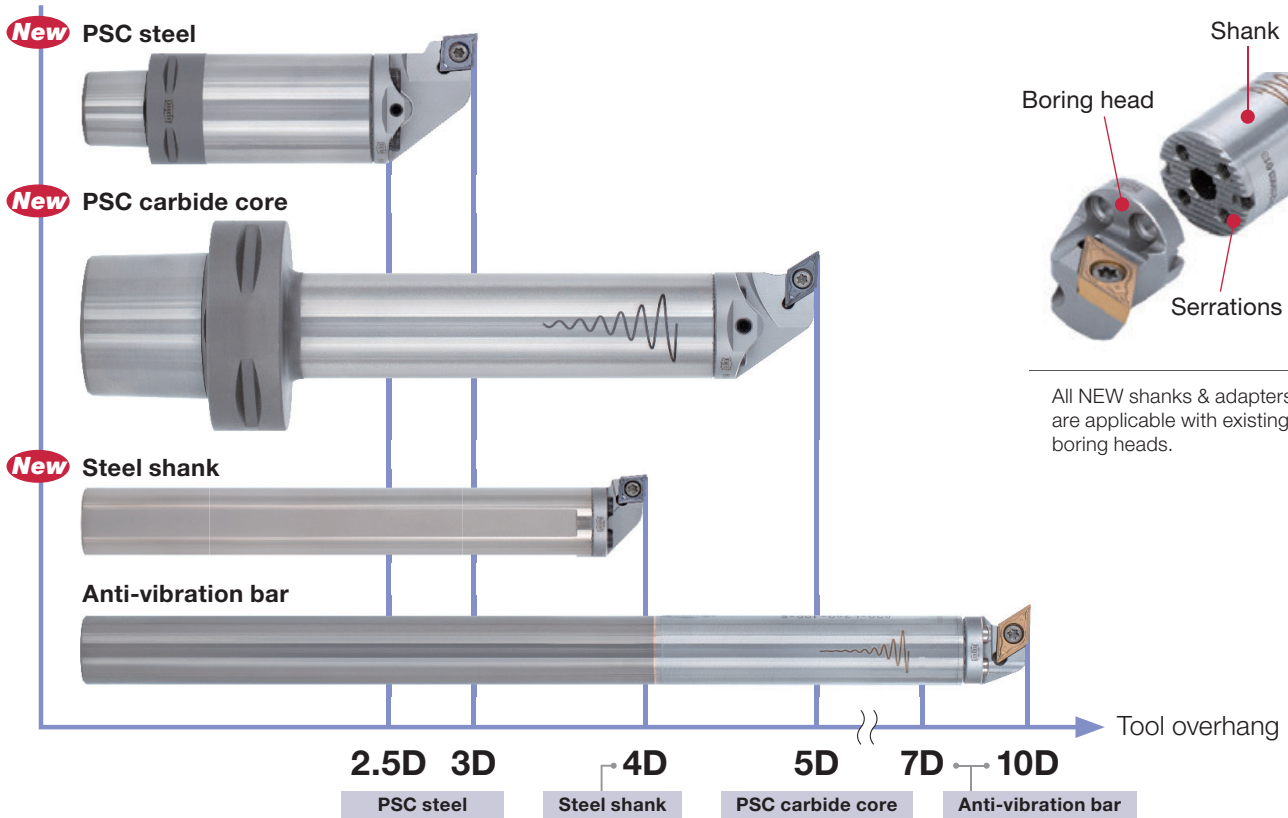

A wide range of cutting heads are available for different insert geometries and latest grades



CUTTING PERFORMANCE

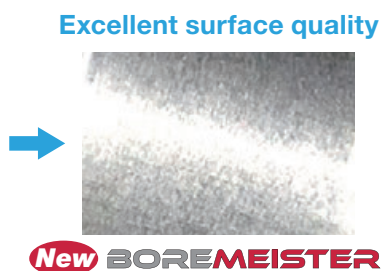

P	Head	: S25-SCLCR09-H
	Shank	: D25-L200-4D-SH (BoreMeister) A25S-SCLCR09-D270 (Conventional)
	Insert	: CCMT09T304-PS AH725
	Workpiece material	: S45C / C45
	Cutting speed	: $V_c = 120$ m/min
	Feed	: $f = 0.15$ mm/rev
	Depth of cut	: $a_p = 0.5$ mm
	Tool overhang	: L/D = 4
	Coolant	: Wet



C#-SH-CHP / C#-SH-E-CHP

PSC compatible adapter with steel or carbide core

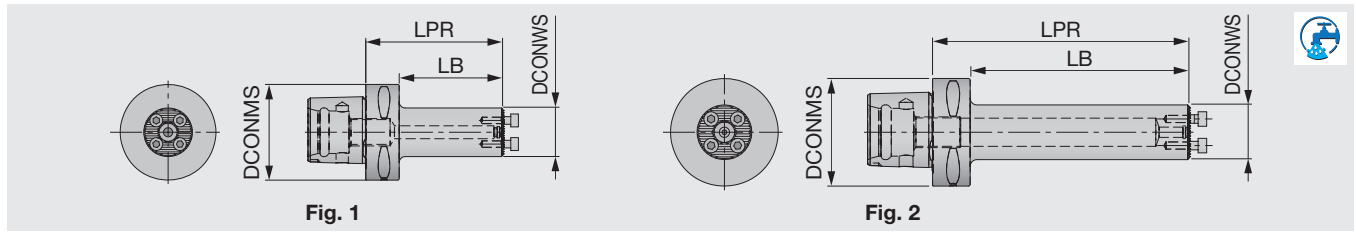

Designation	Material	DCONWS	DCONMS	LPR	LB	Fig
C4-SH-D16-2.5D-CHP	Steel	16	40	40	20	1
C4-SH-D20-2.5D-CHP	Steel	20	40	50	30	1
C4-SH-D25-2.5D-CHP	Steel	25	40	55	35	1
C4-SH-D32-2.5D-CHP	Steel	32	40	75	55	1
C4-SH-D40-3D-CHP	Steel	40	40	80	80	1
C6-SH-D20-5D-E-CHP	Carbide	20	63	100	78	2
C6-SH-D25-5D-E-CHP	Carbide	25	63	115	93	2
C6-SH-D32-5D-E-CHP	Carbide	32	63	150	128	2
C6-SH-D40-5D-E-CHP	Carbide	40	63	185	163	2

SPARE PARTS

Designation	Clamping screw	Wrench
C4**D16...	SRM3X10DIN912	HW2.5
C4/C6**D20...	SRM3.5X10DIN912	HW2.5
C4/C6**D25...	SRM4X12DIN912	HW3.0
C4/C6**D32...	SRM5X12DIN912	HW4.0
C4/C6**D40...	SRM6X16DIN912-12.9	HW5.0

D#4D-SH

Steel shank for internal turning, with through coolant

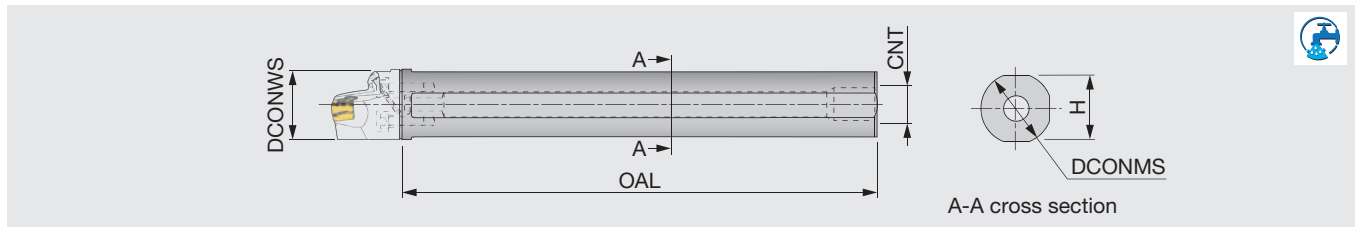

Designation	Material	DCONWS	DCONMS	OAL	CNT	H
D16-L105-4D-SH	Steel	16	16	105	UNC-2B 3/8"-16	15
D20-L140-4D-SH	Steel	20	20	140	UNFC-2B 3/8"-24	18
D25-L200-4D-SH	Steel	25	25	200	UNF-2B 1/2"-20	23
D32-L218-4D-SH	Steel	32	32	218	UNF-2B 1/2"-20	29
D40-L283-4D-SH	Steel	40	40	283	UNF-2B 1/2"-20	36

SPARE PARTS

Designation	Clamping screw	Wrench
D16**4D-SH	SRM3X10DIN912	HW2.5
D20**4D-SH	SRM3.5X10DIN912	HW2.5
D25**4D-SH	SRM4X12DIN912	HW3.0
D32**4D-SH	SRM5X12DIN912	HW4.0
D40**4D-SH	SRM6X16DIN912-12.9	HW5.0

Tungaloy Corporation (Head office)

11-1 Yoshima-Kogyodanchi
Iwaki-city, Fukushima 970-1144 Japan
Phone: +81-246-36-8501
Fax: +81-246-36-8542
www.tungaloy.co.jp

Tungaloy America, Inc.

3726 N Ventura Drive
Arlington Heights, IL 60004, U.S.A.
Phone: +1-888-554-8394
Fax: +1-888-554-8392
www.tungaloy.com/us

Tungaloy Canada

432 Elgin St. Unit 3
Brantford, Ontario N3S 7P7, Canada
Phone: +1-519-758-5779
Fax: +1-519-758-5791
www.tungaloy.com/ca

Tungaloy de Mexico S.A.

C. Los Arellano 113,
Parque Industrial Siglo XXI
Aguascalientes, AGS, Mexico 20290
Phone: +52-449-929-5410
Fax: +52-449-929-5411
www.tungaloy.com/mx

Tungaloy do Brasil Ltda.

Avd. Independencia N4158 Residencial Flora
13280-000 Vinhedo, São Paulo, Brasil
Phone: +55-19-38262757
Fax: +55-19-38262757
www.tungaloy.com/br

Tungaloy Germany GmbH

An der Alten Ziegelei 1
D-40789 Monheim, Germany
Phone: +49-2173-90420-0
Fax: +49-2173-90420-19
www.tungaloy.com/de

Tungaloy France S.A.S.

ZA Courtaboeuf - Le Rio
1 rue de la Terre de feu
F-91952 Courtaboeuf Cedex, France
Phone: +33-1-6486-4300
Fax: +33-1-6907-7817
www.tungaloy.com/fr

Tungaloy Italia S.r.l.

Via E. Andolfato 10
I-20126 Milano, Italy
Phone: +39-02-252012-1
Fax: +39-02-252012-65
www.tungaloy.com/it

Tungaloy Czech s.r.o.

Turanka 115
CZ-627 00 Brno, Czech Republic
Phone: +420-532 123 391
Fax: +420-532 123 392
www.tungaloy.com/cz

Tungaloy Ibérica S.L.

C/Miquel Servet, 43B, Nau 7
Pol. Ind. Bufalvent
ES-08243 Manresa (BCN), Spain
Phone: +34 93 113 1360
Fax: +34 93 876 2798
www.tungaloy.com/es

Tungaloy Scandinavia AB

Bultgatan 38
442 40 Kungälv, Sweden
Phone: +46-462119200
Fax: +46-462119207
www.tungaloy.com/se

Tungaloy Rus, LLC

Andropova avenue, h.18/7,
11 floor, office 3, 115432,
Moscow, Russia
Phone: +7-499-683-01-80
Fax: +7-499-683-01-81
www.tungaloy.com/ru

Tungaloy Polska Sp. z o.o.

Ul. Irysowa 1, 55-040 Bielany
Wroclawskie, Poland
Phone: +48 607 907 237
www.tungaloy.com/pl

Tungaloy U.K. Ltd

Gallan Park, Watling Street,
Cannock, WS110XG, UK
Phone: +44 121 4000 231
Fax: +44 121 270 9694
www.tungaloy.com/uk

Tungaloy Hungary Kft

Erzsébet királyné útja 125
H-1142 Budapest, Hungary
Phone: +36 1 781-6846
Fax: +36 1 781-6866
www.tungaloy.com/hu

Tungaloy Turkey

Serifali Mah.bayraktar Bulvari Kule Sk. No:26
34775 Umraniye / Istanbul / Turkey
Phone: +90 216 540 04 67
Fax: +90 216 540 04 87
www.tungaloy.com/tr

Tungaloy Benelux b.v.

Tjalk 70
NL-2411 NZ Bodegraven, Netherlands
Phone: +31 172 630 420
Fax: +31 172 630 429
www.tungaloy.com/nl

Tungaloy Croatia

Ulica bana Josipa Jelačića 87,
10430, Samobor, Croatia
Phone: +385 1 3326 604
Fax: +385 1 3327 683
www.tungaloy.com/hr

Tungaloy Cutting Tool (Shanghai) Co.,Ltd.

Rm No 401 No.88 Zhabei
Jiangchang No.3 Rd
Shanghai 200436, China
Phone: +86-21-3632-1880
Fax: +86-21-3621-1918
www.tungaloy.com/cn

Tungaloy Cutting Tools (Taiwan) Co.,Ltd.

9F. No.293, Zhongyang Rd,
Xinzhuan Dist, New Taipei City,
24251 Taiwan
Phone: +886-2-8521-9986
Fax: +886-2-8521-8935
www.tungaloy.com/tw

Tungaloy Cutting Tools (Thailand) Co.,Ltd.

Interlink tower 4th Fl.
1858/5-7 Bangna-Trad Road
km.5 Bangna, Bangna, Bangkok 10260
Thailand
Phone: +66-2-751-5711
Fax: +66-2-751-5715
www.tungaloy.com/th

Tungaloy Singapore (Pte.), Ltd.

62 Ubi Road 1, #06-11 Oxley BizHub 2
Singapore 408734
Phone: +65-6391-1833
Fax: +65-6299-4557
www.tungaloy.com/sing

Tungaloy Vietnam

LE04.38, Lexington Residence
67 Mai Chi Tho St., Dist. 2,
Ho Chi Minh City, Vietnam
Phone: +84-2837406660
www.tungaloy.com/sing

Tungaloy India Pvt. Ltd.

Indiabulls Finance Centre,
Unit # 902-A, 9th Floor,
Tower 1, Senapati Bapat Marg,
Elphinstone Road (West),
Mumbai-400013, India
Phone: +91-22-6124-8804
Fax: +91-22-6124-8899
www.tungaloy.com/in

Tungaloy Korea Co., Ltd

#1312, Byucksan Digital Valley 5-cha
Beotkkot-ro 244, Geumcheon-gu
153-788 Seoul, Korea
Phone: +82-2-2621-6161
Fax: +82-2-6393-8952
www.tungaloy.com/kr

Tungaloy Malaysia Sdn Bhd

50 K-2, Kelana Mall, Jalan SS6/14
Kelana Jaya, 47301
Petaling Jaya, Selangor Darul Ehsan
Malaysia
Phone: +603-7805-3222
Fax: +603-7804-8563
www.tungaloy.com/my

Tungaloy Australia Pty Ltd

Unit 68 1470 Ferntree Gully Road
Knoxfield 3180 Victoria, Australia
Phone: +61-3-9755-8147
Fax: +61-3-9755-6070
www.tungaloy.com/au

PT. Tungaloy Indonesia

Kompleks Grand Wisata Block AA-10 No.3-5
Cibitung
Bekasi 17510, Indonesia
Phone: +62-21-8261-5808
Fax: +62-21-8261-5809
www.tungaloy.com/id



www.tungaloy.com

follow us at:

facebook.com/tungaloyjapan
twitter.com/tungaloyjapan
www.youtube.com/tungaloycorporation



AS9100 Certified
78006
2015.11.04
ISO 14001 Certified
EC97J1123
1997.11.26

Distributed by:



FIND US ON THE CLOUD!
machiningcloud.com



BOREMEISTER

Tungaloy Report No. 517S3-G

Expansion of ID boring and threading heads

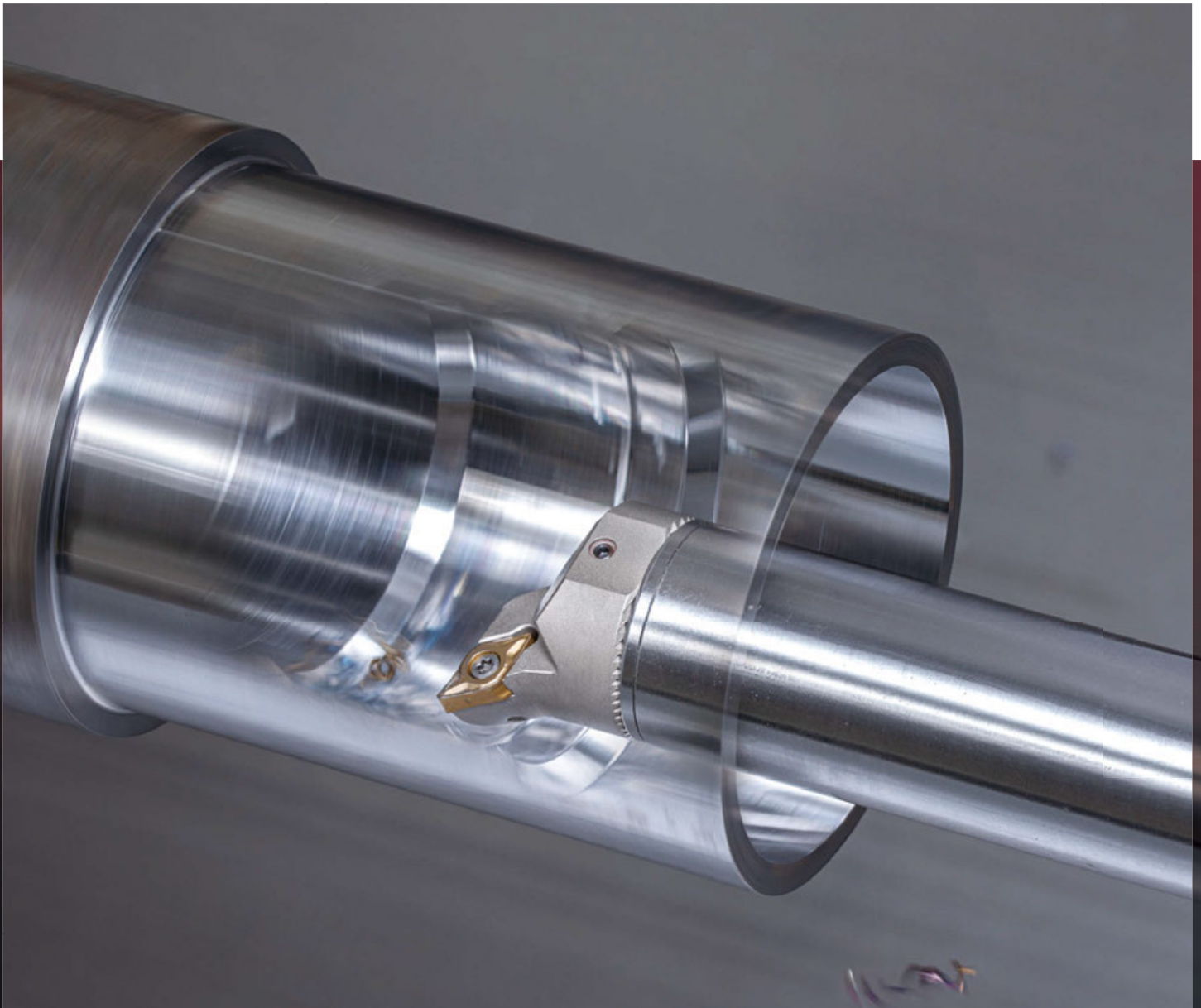









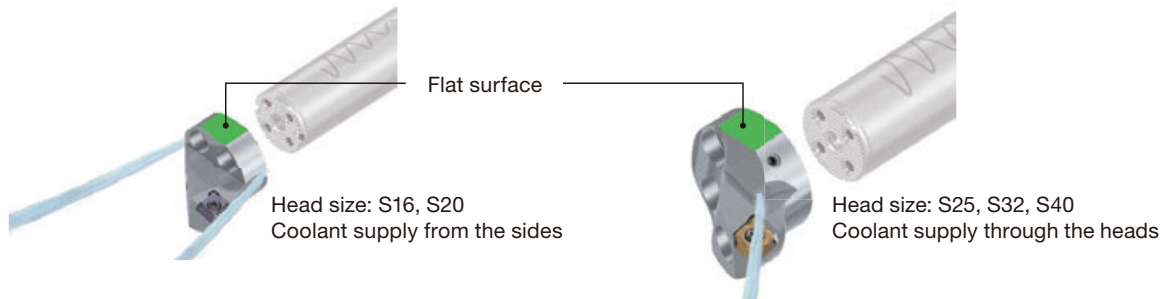

Various applications with wider lineup

New heads features

- New heads with latest insert geometry and grade offers **high productivity and stable machining**
- Internal coolant supply drastically **improves chip evacuation**
- Flat surface enables **easy setup and adjustments** of the tool center height



New lineup

Series	Head / Insert	DMIN	Page
MINIFURN	   CXMU... DXG/MU... WXGU...	ø32	P.3 and 4
TUNGBMINI	 XOMU...	ø25	P.4
ISOETURN	  CNMG09... TNMG11...	ø40	P.5
ISOTURN	 TPMT...	ø20	P.6
TUNGTHREAD	 16IR...	ø25	P.6

All new heads are applicable with existing shanks and adapters

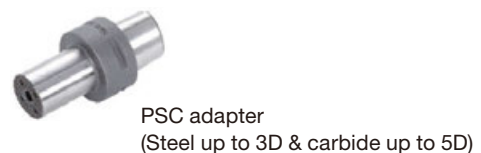

S-SCLXR/L-H

Screw-on clamp exchangeable boring head, for CXMU inserts

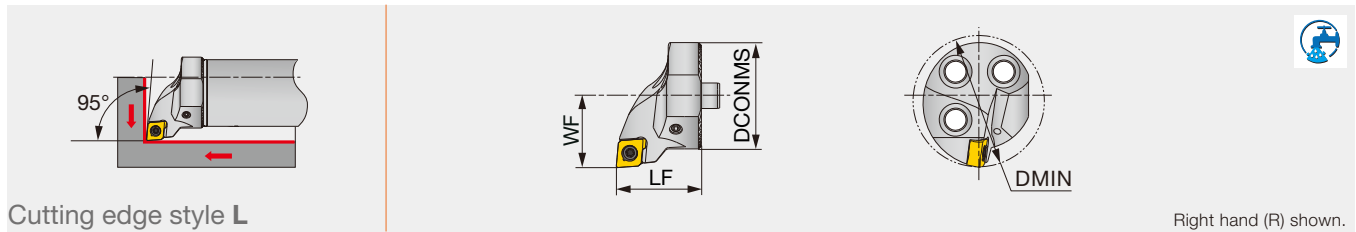

Designation	DMIN	DCONMS	WF	LF	Shank	Insert
S25-SCLXR/L06-H	32	25	17	20	D25	CXMU...
S32-SCLXR/L06-H	40	32	22	32	D32	CXMU...
S40-SCLXR/L06-H	50	40	27	32	D40, D50, D60	CXMU...

Note: Use right-hand toolholders (SCLXR**) with left-hand inserts (L); and left-hand toolholders (SCLXL**) with right-hand inserts (R).

SPARE PARTS

Designation	Clamping screw	Wrench
S**-SCLXR/L06-H	SR34-514	T-7F

S-SDXXR/L-H

Screw-on clamp exchangeable boring head, for DXG/MU inserts

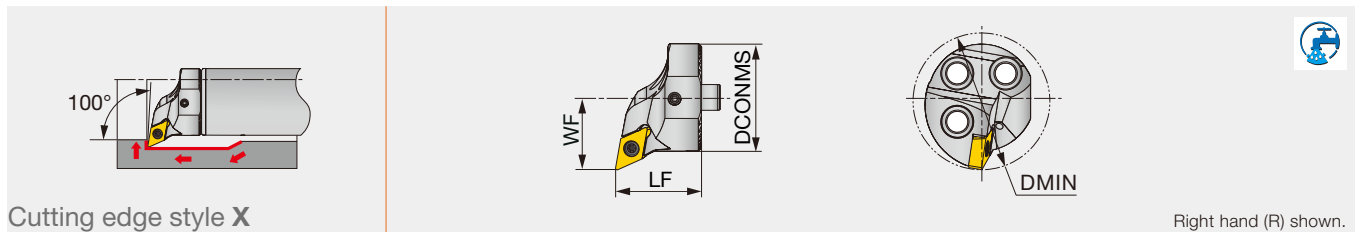

Designation	DMIN	DCONMS	WF	LF	Shank	Insert
S25-SDXXR/L07-H	32	25	17	20	D25	DXG/MU...
S32-SDXXR/L07-H	40	32	22	32	D32	DXG/MU...
S40-SDXXR/L07-H	50	40	27	32	D40, D50, D60	DXG/MU...

Note: Use right-hand toolholders (SDXXR**) with left-hand inserts (L); and left-hand toolholders (SDXXL**) with right-hand inserts (R).

SPARE PARTS

Designation	Clamping screw	Wrench
S**-SDXXR/L07-H	SR34-514	T-7F

S-SWLXR/L-H

Screw-on clamp exchangeable boring head, for WXGU inserts

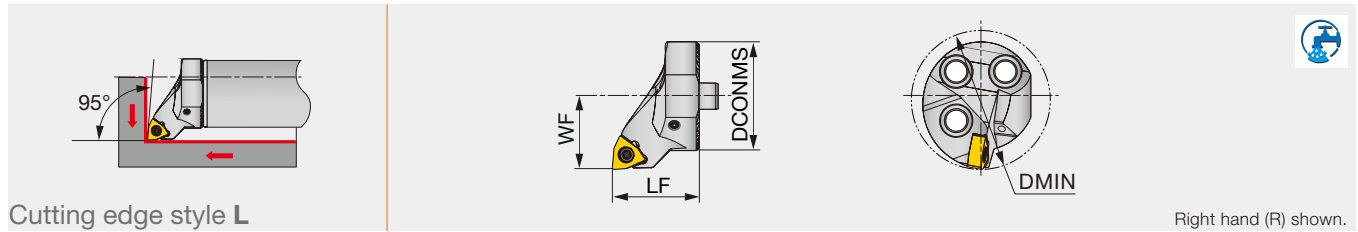

Cutting edge style L

Right hand (R) shown.

Designation	DMIN	DCONMS	WF	LF	Shank	Insert
S25-SWLXR/L04-H	32	25	17	20	D25	WXGU...
S32-SWLXR/L04-H	40	32	22	32	D32	WXGU...
S40-SWLXR/L04-H	50	40	27	32	D40, D50, D60	WXGU...

Note: Use right-hand toolholders (SWLXR**) with left-hand inserts (L); and left-hand toolholders (SWLXL**) with right-hand inserts (R).

SPARE PARTS

Designation	Clamping screw	Wrench
S**-SWLXR/L04-H	SR34-514	T-7F

S-SXUOR05-H

Screw-on clamp exchangeable boring head, for XOMU inserts

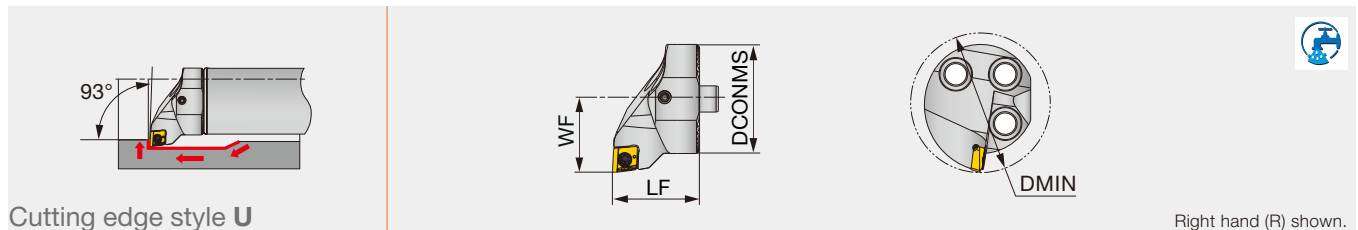

Cutting edge style U

Right hand (R) shown.

Designation	DMIN	DCONMS	WF	LF	Shank	Insert
S20-SXUOR05-H	25	20	13	20	D20	XOMU...
S25-SXUOR05-H	32	25	17	20	D25	XOMU...

SPARE PARTS

Designation	Clamping screw	Wrench
S**-SXUOR05-H	CSTB-2L040	T-6F

S-PCLNR/L-H

Lever-lock clamp exchangeable boring head, for negative 80° rhombic inserts

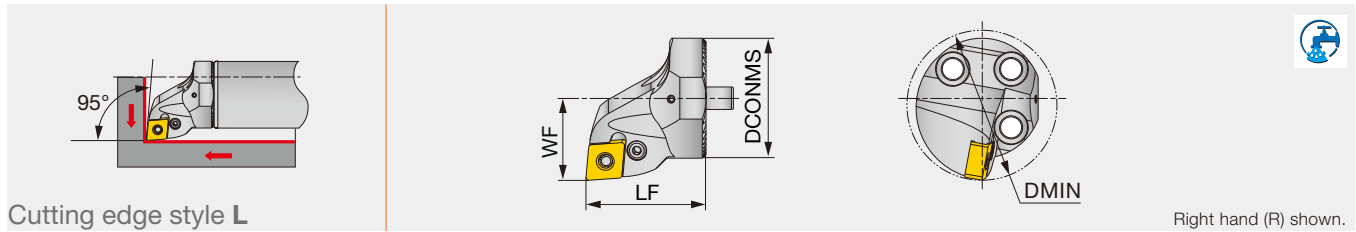

Cutting edge style L

Right hand (R) shown.

Designation	DMIN	DCONMS	WF	LF	Shank	Insert
S32-PCLNR/L09-H	40	32	22	32	D32	CNMG0904...
S40-PCLNR/L09-H	50	40	27	32	D40, D50, D60	CNMG0904...

Note: Use right-hand toolholders (PCLNR**) with left-hand inserts (L); and left-hand toolholders (PCLNL**) with right-hand inserts (R).

SPARE PARTS

Designation	Lever	Clamping screw	Shim	Spring pin	Wrench
S32-PCLNR/L09-H	LCL33N	LCS33	-	-	P-2F
S40-PCLNR/L09-H	LCL33	LCS3	LSC317	LSP3	P-2.5

S-PTFNR/L-H

Lever-lock clamp exchangeable boring head, for negative 60° triangular inserts

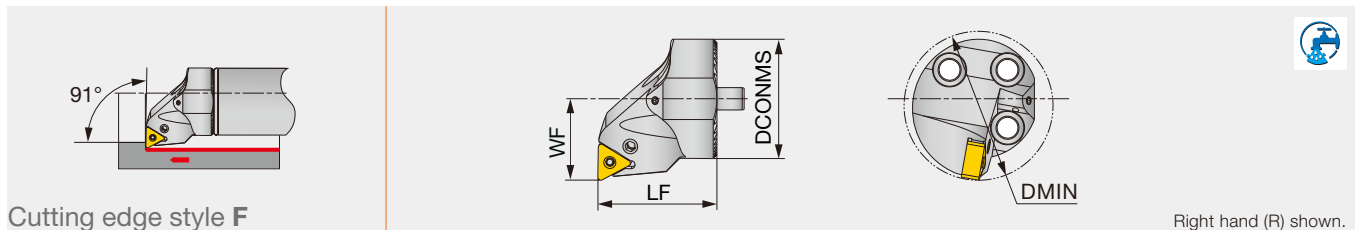

Cutting edge style F

Right hand (R) shown.

Designation	DMIN	DCONMS	WF	LF	Shank	Insert
S32-PTFNR/L11-H	40	32	22	32	D32	TNMG1104...
S40-PTFNR/L11-H	50	40	27	32	D40, D50, D60	TNMG1104...

Note: Use right-hand toolholders (PTFNR**) with left-hand inserts (L); and left-hand toolholders (PTFNL**) with right-hand inserts (R).

SPARE PARTS

Designation	Lever	Clamping screw	Wrench
S**-PTFNR/L11-H	LCL23	LCS23A	P-2.5

S-STFPR/L-H

ISOTURN

Screw-on clamp exchangeable boring head, for positive 60° triangular inserts

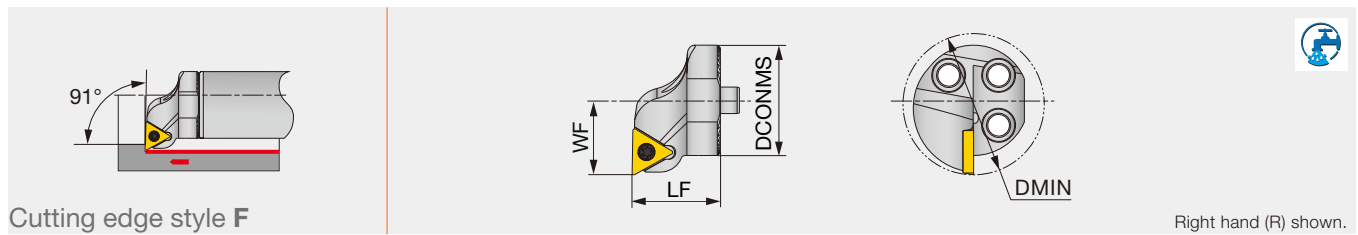

Cutting edge style F

Right hand (R) shown.

Designation	DMIN	DCONMS	WF	LF	Shank	Insert
S16-STFPR/L09-H	20	16	11	20	D16	TPMT0902...
S16-STFPR/L11-H	20	16	11	20	D16	TPMT1102...
S20-STFPR/L11-H	25	20	13	20	D20	TPMT1102...
S25-STFPR/L11-H	32	25	17	20	D25	TPMT1102...
S32-STFPR/L16-H	40	32	22	32	D32	TPMT16T3...
S40-STFPR/L16-H	50	40	27	32	D40, D50, D60	TPMT16T3...

Note: Use right-hand toolholders (STFPR**) with left-hand inserts (L); and left-hand toolholders (STFPL**) with right-hand inserts (R).

SPARE PARTS



Designation	Clamping screw	Wrench
S16-STFPR/L09-H	CSTB-2.2S	T-7F
S16-STFPR/L11-H	CSTB-2.5	T-8F
S20-STFPR/L11-H	CSTB-2.5	T-8F
S25-STFPR/L11-H	CSTB-2.5	T-8F
S32-STFPR/L16-H	CSTB-4M	T-15F
S40-STFPR/L16-H	CSTB-4M	T-15F

S-SNR-H

TUNGTHREAD

Screw-on clamp exchangeable boring head, for threading inserts

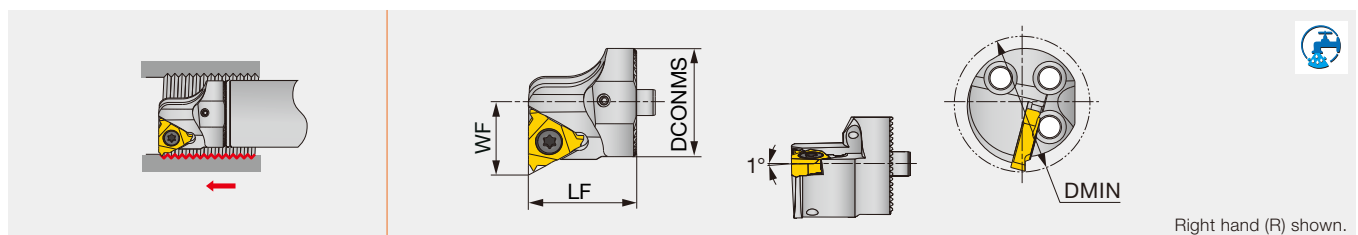

Right hand (R) shown.

Designation	DMIN	DCONMS	WF	LF	Shank	Insert
S20-SNR16-H	25	20	14	25	D20	16IR...
S25-SNR16-H	32	25	17	25	D25	16IR...
S32-SNR16-H	40	32	22	32	D32	16IR...
S40-SNR16-H	50	40	27	32	D40, D50, D60	16IR...

SPARE PARTS



Designation	Clamping screw	Wrench
S**-SNR16-H	CSTB-3.5	T-15F

MEMO

A large grid of graph paper, consisting of 25 columns and 35 rows of small squares, intended for writing a memo.

Tungaloy Corporation (Head office)

11-1 Yoshima-Kogyodanchi
Iwaki-city, Fukushima 970-1144 Japan
Phone: +81-246-36-8501
Fax: +81-246-36-8542
www.tungaloy.co.jp

Tungaloy America, Inc.

3726 N Ventura Drive
Arlington Heights, IL 60004, U.S.A.
Phone: +1-888-554-8394
Fax: +1-888-554-8392
www.tungaloy.com/us

Tungaloy Canada

432 Elgin St. Unit 3
Brantford, Ontario N3S 7P7, Canada
Phone: +1-519-758-5779
Fax: +1-519-758-5791
www.tungaloy.com/ca

Tungaloy de Mexico S.A.

C. Los Arellano 113,
Parque Industrial Siglo XXI
Aguascalientes, AGS, Mexico 20290
Phone: +52-449-929-5410
Fax: +52-449-929-5411
www.tungaloy.com/mx

Tungaloy do Brasil Ltda.

Avd. Independencia N4158 Residencial Flora
13280-000 Vinhedo, São Paulo, Brasil
Phone: +55-19-38262757
Fax: +55-19-38262757
www.tungaloy.com/br

Tungaloy Germany GmbH

An der Alten Ziegelei 1
D-40789 Monheim, Germany
Phone: +49-2173-90420-0
Fax: +49-2173-90420-19
www.tungaloy.com/de

Tungaloy France S.A.S.

ZA Courtaboëuf - Le Rio
1 rue de la Terre de feu
F-91952 Courtaboëuf Cedex, France
Phone: +33-1-6486-4300
Fax: +33-1-6907-7817
www.tungaloy.com/fr

Tungaloy Italia S.r.l.

Via E. Andolfato 10
I-20126 Milano, Italy
Phone: +39-02-252012-1
Fax: +39-02-252012-65
www.tungaloy.com/it

Tungaloy Czech s.r.o.

Turanka 115
CZ-627 00 Brno, Czech Republic
Phone: +420-532 123 391
Fax: +420-532 123 392
www.tungaloy.com/cz

Tungaloy Ibérica S.L.

C/Miquel Servet, 43B, Nau 7
Pol. Ind. Bufalvent
ES-08243 Manresa (BCN), Spain
Phone: +34 93 113 1360
Fax: +34 93 876 2798
www.tungaloy.com/es

Tungaloy Scandinavia AB

Bultgatan 38
442 40 Kungälv, Sweden
Phone: +46-462119200
Fax: +46-462119207
www.tungaloy.com/se

Tungaloy Rus, LLC

Andropova avenue, h.18/7,
11 floor, office 3, 115432,
Moscow, Russia
Phone: +7-499-683-01-80
Fax: +7-499-683-01-81
www.tungaloy.com/ru

Tungaloy Polska Sp. z o.o.

Ul. Irysowa 1, 55-040 Bielany
Wroclawskie, Poland
Phone: +48 607 907 237
www.tungaloy.com/pl

Tungaloy U.K. Ltd

Gallan Park, Watling Street,
Cannock, WS110XG, UK
Phone: +44 121 4000 231
Fax: +44 121 270 9694
www.tungaloy.com/uk

Tungaloy Hungary Kft

Erzsébet királyné útja 125
H-1142 Budapest, Hungary
Phone: +36 1 781-6846
Fax: +36 1 781-6866
www.tungaloy.com/hu

Tungaloy Turkey

Serifali Mah.bayraktar Bulvari Kule Sk. No:26
34775 Umraniye / Istanbul / Turkey
Phone: +90 216 540 04 67
Fax: +90 216 540 04 87
www.tungaloy.com/tr

Tungaloy Benelux b.v.

Tjalk 70
NL-2411 NZ Bodegraven, Netherlands
Phone: +31 172 630 420
Fax: +31 172 630 429
www.tungaloy.com/nl

Tungaloy Croatia

Ulica bana Josipa Jelačića 87,
10430, Samobor, Croatia
Phone: +385 1 3326 604
Fax: +385 1 3327 683
www.tungaloy.com/hr

Tungaloy Cutting Tool (Shanghai) Co.,Ltd.

Rm No 401 No.88 Zhabei
Jiangchang No.3 Rd
Shanghai 200436, China
Phone: +86-21-3632-1880
Fax: +86-21-3621-1918
www.tungaloy.com/cn

Tungaloy Cutting Tools (Taiwan) Co.,Ltd.

9F. No.293, Zhongyang Rd,
Xinzhuang Dist, New Taipei City,
24251 Taiwan
Phone: +886-2-8521-9986
Fax: +886-2-8521-8935
www.tungaloy.com/tw

Tungaloy Cutting Tools (Thailand) Co.,Ltd.

Interlink tower 4th Fl.
1858/5-7 Bangna-Trad Road
km.5 Bangna, Bangna, Bangkok 10260
Thailand
Phone: +66-2-751-5711
Fax: +66-2-751-5715
www.tungaloy.com/th

Tungaloy Singapore (Pte.), Ltd.

62 Ubi Road 1, #06-11 Oxley BizHub 2
Singapore 408734
Phone: +65-6391-1833
Fax: +65-6299-4557
www.tungaloy.com/sg

Tungaloy Vietnam

LE04.38, Lexington Residence
67 Mai Chi Tho St., Dist. 2,
Ho Chi Minh City, Vietnam
Phone: +84-2837406660
www.tungaloy.com/sg

Tungaloy India Pvt. Ltd.

Indiabulls Finance Centre,
Unit # 902-A, 9th Floor,
Tower 1, Senapati Bapat Marg,
Elphinstone Road (West),
Mumbai-400013, India
Phone: +91-22-6124-8804
Fax: +91-22-6124-8899
www.tungaloy.com/in

Tungaloy Korea Co., Ltd

#1312, Byucksan Digital Valley 5-cha
Beotkkot-ro 244, Geumcheon-gu
153-788 Seoul, Korea
Phone: +82-2-2621-6161
Fax: +82-2-6393-8952
www.tungaloy.com/kr

Tungaloy Malaysia Sdn Bhd

50 K-2, Kelana Mall, Jalan SS6/14
Kelana Jaya, 47301
Petaling Jaya, Selangor Darul Ehsan
Malaysia
Phone: +603-7805-3222
Fax: +603-7804-8563
www.tungaloy.com/my

Tungaloy Australia Pty Ltd

Unit 68 1470 Ferntree Gully Road
Knoxfield 3180 Victoria, Australia
Phone: +61-3-9755-8147
Fax: +61-3-9755-6070
www.tungaloy.com/au

PT. Tungaloy Indonesia

Kompleks Grand Wisata Block AA-10 No.3-5
Cibitung
Bekasi 17510, Indonesia
Phone: +62-21-8261-5808
Fax: +62-21-8261-5809
www.tungaloy.com/id



www.tungaloy.com

follow us at:

facebook.com/tungaloyjapan
twitter.com/tungaloyjapan
www.youtube.com/tungaloycorporation



AS9100 Certified
78006
2015.11.04
ISO 14001 Certified
EC97J1123
1997.11.26

Distributed by:



FIND US ON THE CLOUD!
machingcloud.com



Available on the
App Store



GET IT ON
Google play



Available on the
App Store



GET IT ON
Google play