

Fresa ad inserti bilaterali positivi

per semi-finitura e finitura

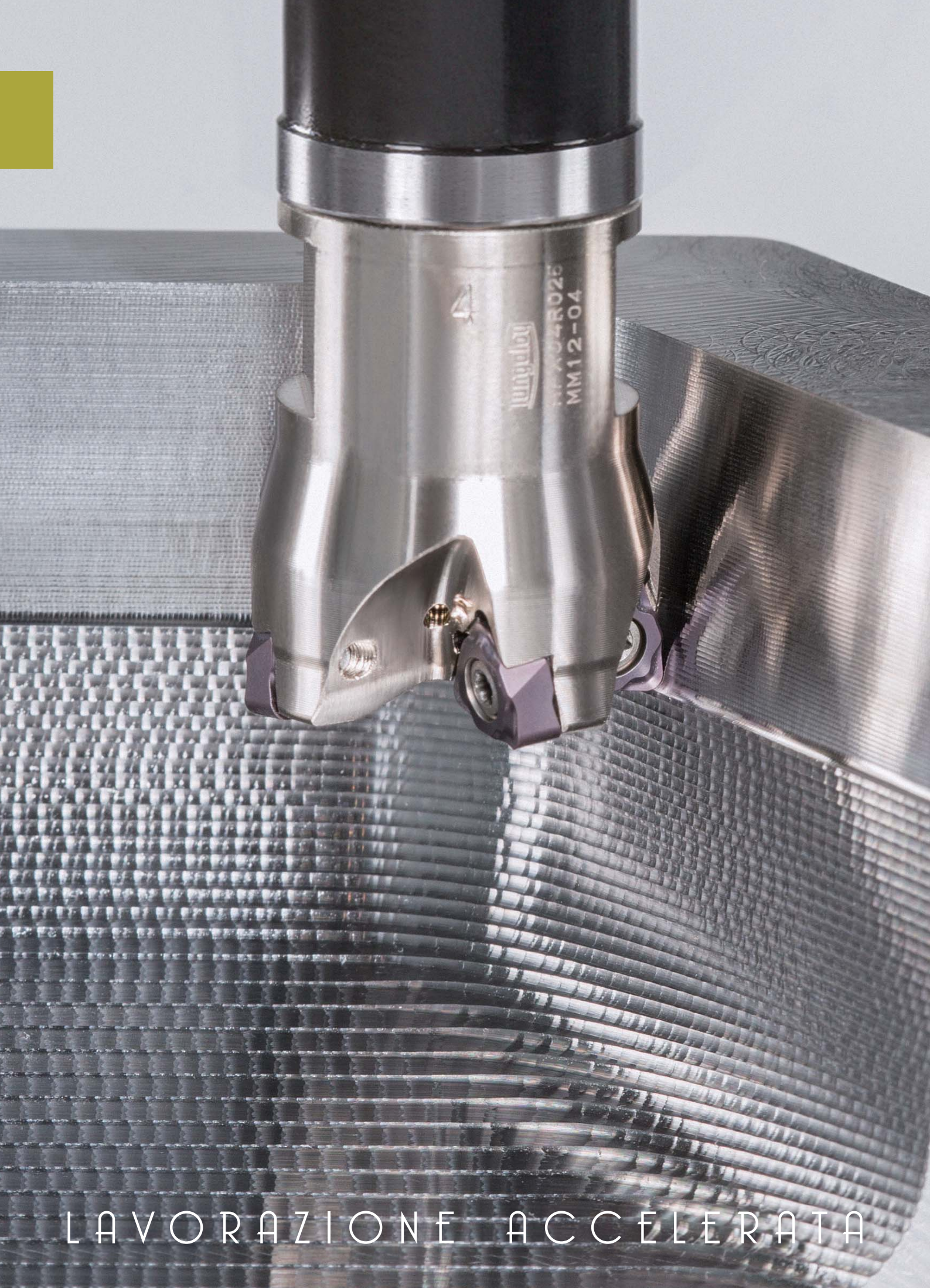



LAVORAZIONE ACCELERATA



DoMini-Mill, una fresa economicamente vantaggiosa
con inserto bilaterale a 6 taglienti positivi per la
copiatura di stampi.

Fresa multifunzionale di semi-finitura e finitura per operazioni di copiatura e lavorazioni a tuffo

Inserto bilaterale con tagliente positivo - geometria innovativa

- L'esclusivo profilo elicoidale consente un'inclinazione positiva all'inserto bilaterale.
 - L'inserto positizzato e il tagliente affilato migliorano l'azione di taglio e la finitura superficiale.
- L'inserto a 6 taglienti è economicamente molto vantaggioso.

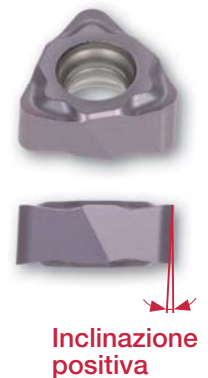
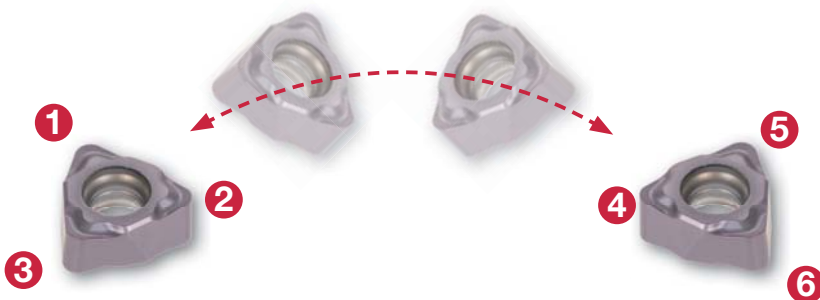

Elevata stabilità

- Il bloccaggio a coda di rondine assicura la rigidità di staffaggio necessaria alla lavorazione 3D.
 - Migliora l'affidabilità nelle operazioni a tuffo.
- Lo scarico posteriore consente di eseguire l'operazione di spallamento retto in modo agevole, evitando l'intasamento dei trucioli.
- Geometria del tagliente ottimizzata per resistere alla scheggiatura nella lavorazione di acciai e materiali temprati.

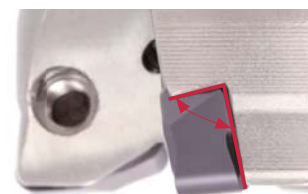

Sistema di bloccaggio a coda di rondine

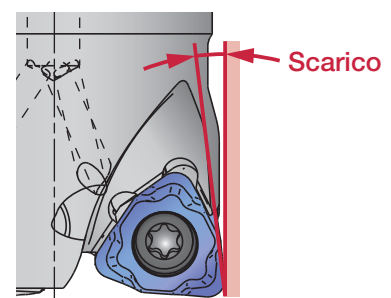

Grande versatilità

- Testine modulari disponibili sia con il filetto di calettamento metrico universale che con il filetto specifico per i codoli TungMeister. Vasto campo di impiego in abbinamento ai codoli TungHold e TungMeister.
- L'ampia scelta di lunghezze e materiali garantisce versatilità operativa.



Inserti

- Inserti precisi in classe H realizzano un runout minimo.
- 2 misure di raggio inserto disponibili:
 - R = 0.5 mm: per impieghi generali a basse profondità e piccole larghezze di taglio
 - R = 1.0 mm: ideale per la lavorazione degli acciai temprati grazie al raggio più resistente
- AH110 grado rivestito PremiumGTec molto resistente all'usura e ideale per la lavorazione dei materiali temprati.

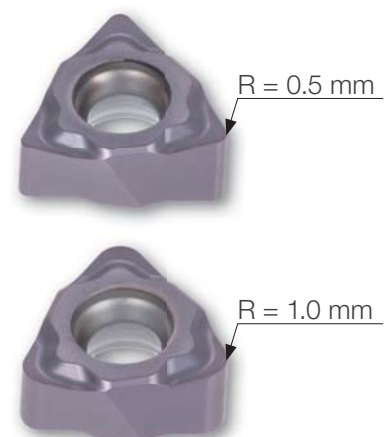

WXHU04-MJ



RENDIMENTI

Finitura superficiale

P Acciaio al carbonio

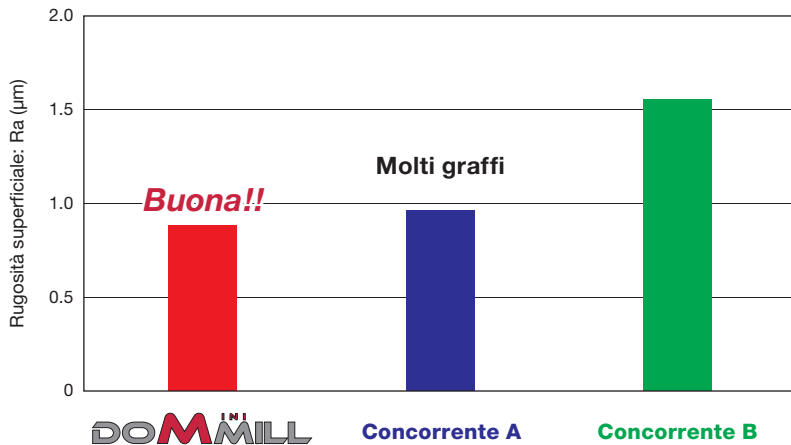

Fresa : HFWX04M016M08R02
 ($\phi Dc = 16 \text{ mm}$, $z = 2$)
 Inserto : WXHU040305R-MJ
 Materiale : SCM440 / 42CrMo4 (302HB)
 Velocità di taglio : $Vc = 300 \text{ m/min}$
 Avanzamento dente : $fz = 0.15 \text{ mm/dente}$
 Prof. di taglio : $ap = 0.15 \text{ mm}$
 Larghezza di taglio : $ae = 0.5 \text{ mm}$

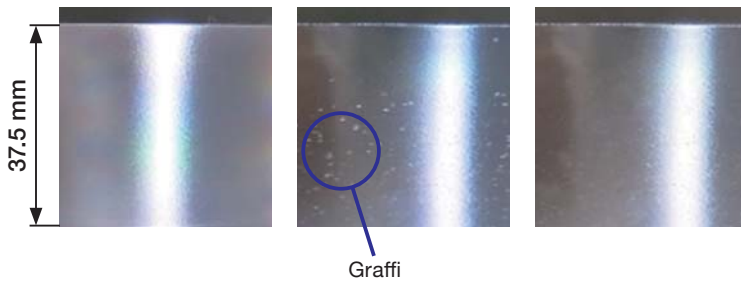
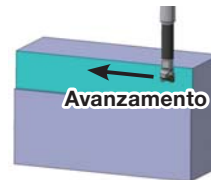

Vita utensile

H Acciai temprati

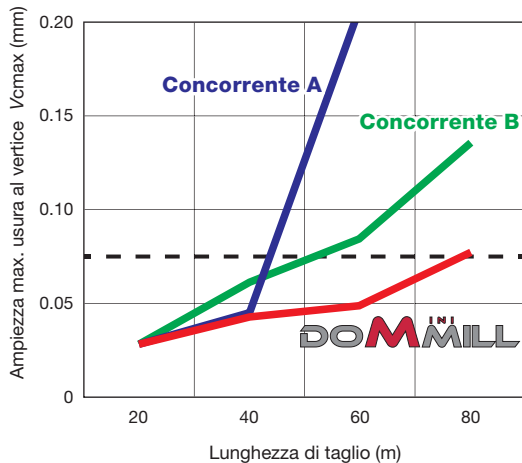

Fresa : HFWX04M016M08R02 ($\phi Dc = 16 \text{ mm}$, $z = 2$)
 Inserto : WXHU040305R-MJ
 Materiale : SKD11 / X153CrMoV12 (58.5HRC)
 Velocità di taglio : $Vc = 100 \text{ m/min}$
 Avanzamento dente : $fz = 0.15 \text{ mm/dente}$
 Prof. di taglio : $ap = 0.15 \text{ mm}$
 Larghezza di taglio : $ae = 0.2 \text{ mm}$



Testine modulari per finitura e semi-finitura

TESTINA MODULARE - FILETTO METRICO

DoMini-Mill HFWX04***M

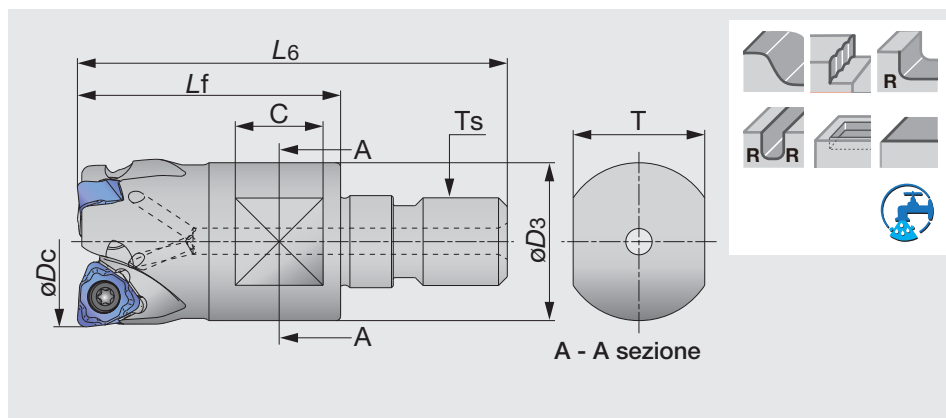

Denominazione	ϕD_c	z	L6	Lf	C	T	D3	Ts	Kg	Inserto
HFWX04M016M08R02	16.00	2	42.0	25.0	8.0	10.0	12.8	M8	0.03	WXHU04**
HFWX04M020M10R03	20.00	3	49.0	30.0	10.0	15.0	17.8	M10	0.05	WXHU04**
HFWX04M025M12R04	25.00	4	52.0	30.0	10.0	17.0	20.8	M12	0.09	WXHU04**

Per il programma degli steli, vedi serie TungFlex Tungaloy Report 413 TungHold

PARTI DI RICAMBIO

Vite di fissaggio
SR34-514Chiave
T-7F

Testine modulari per finitura e semi-finitura

TESTINA MODULARE - FILETTO TUNGMEISTER

DoMini-Mill HFWX04***S

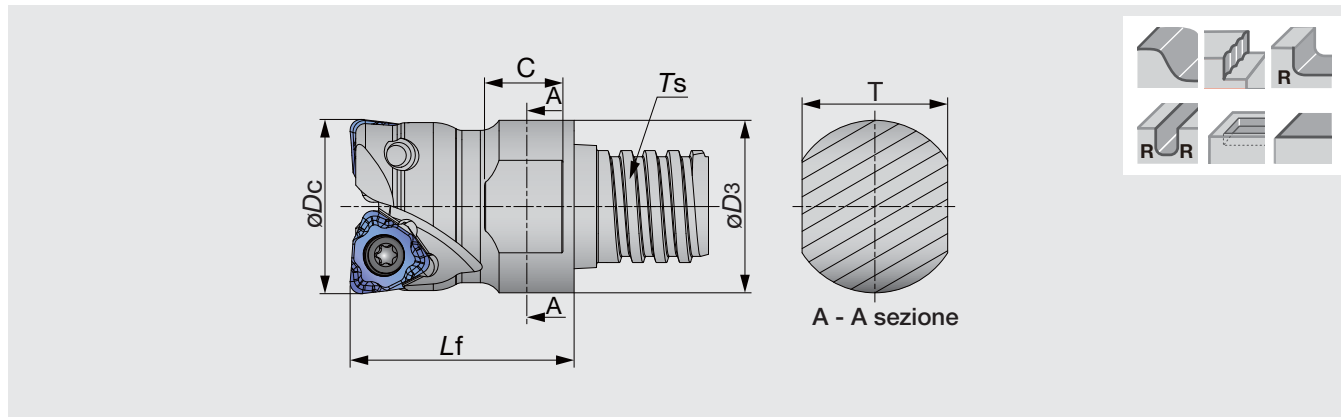

Denominazione	ϕD_c	z	L_f	C	T	D_3	T_s	Kg	Inserto
HFWX04M016S10R02	16	2	20	7	13	15.4	S10	0.03	WXHU04**
HFWX04M020S12R03	20	3	25	7	16	18.5	S12	0.06	WXHU04**
HFWX04M025S15R04	25	4	30	7	20	24.1	S15	0.11	WXHU04**

- Per approfondimenti sui codoli vedi Tungaloy Report 381 TungMeister
Codoli: VSSD, VTSD, VSC, VSTD

- Per calettamenti tra codolo metrico e filetto TungMeister, usare l'adattatore VAD-M

Chiave	Denominazione	Filetto di calettamento
	KEYV-S10	S10
	KEYV-S12	S12
	KEYV-W20	S15

Opzionale - da ordinare separatamente.

PARTI DI RICAMBIO

Vite inserto	Chiave
SR34-514	T-7F

INSERTI

WXHU-MJ

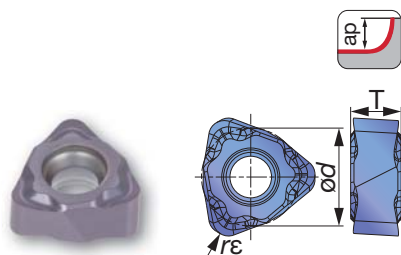

Denominazione	Max. ap	IC dia	T	rε	AH110	
WXHU040305R-MJ	0.5	6.35	3.18	0.5	●	●
WXHU040310R-MJ	1	6.35	3.18	1	●	●
					P	H

* Per le operazioni a tuffo è possibile prof. di taglio fino a 2 mm

● Prima scelta

PARAMETRI DI TAGLIO STANDARD

ISO	Materiali da lavorare	Durezza (HB)	Grado	Vel. di taglio Vc (m/min)	Avanzamento fz (mm/dente)
P	Acciai ad elevato tenore di carbonio (S45C / C45, S55C / C55, ecc.)	200 - 300	AH110	100 - 300	0.1 - 0.3
	Acciai legati (SCM440 / 42CrMo4, SCr145, ecc.)	150 - 300	AH110	100 - 300	0.1 - 0.3
	Acciai pretempra (NAK80, PX5, ecc.)	-	AH110	100 - 300	0.05 - 0.3
H	Acciai temprati	(SKD61 / X40CrMoV5-1, ecc.)	AH110	80 - 130	0.1 - 0.3
		(SKD11 / X153CrMoV12, ecc.)	AH110	50 - 100	0.05 - 0.15

ESEMPI DI LAVORAZIONE

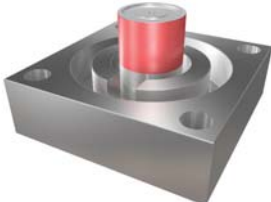
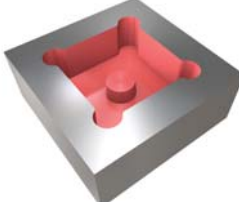
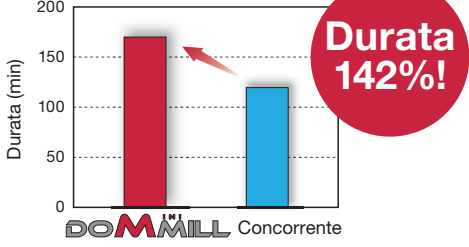
Pezzo	Stampo	Stampo	
Fresa	HFWX04M020M10R03 (ø20 mm, z = 3)	HFWX04M025M12R04 (ø25 mm, z = 4)	
Inserto	WXHU040310R-MJ	WXHU040310R-MJ	
Grado	AH110	AH110	
Materiale da lavorare	2738 (28 – 32 HRC) 	DIN 1.2344 (50 – 52HRC) 	
Parametri di taglio	Vel. di taglio : Vc (m/min)	195	274
	Avanzamento: fz (mm/dente)	0.16	0.14
	Avanz. tavola : Vf (mm/min)	1500	2000
	Prof. di taglio : ap (mm)	0.25	0.11
	Largh. di taglio: ae (mm)	0.35	-
	Operazione	Copiatura	Copiatura
	Refrigerante	Sì (interno, 40bar)	A secco
Macchina	Centro verticale	Centro verticale	
Risultati	 <p>Durata 142%!</p> <p>DoMini-Mill ha prolungato la vita utensile del 42% grazie alle basse forze di taglio e al grado dell'inserto molto resistente all'usura.</p>		
	<p>5 ore di lavorazione! Il nuovo grado PremiumG-Tec con superiore resistenza all'usura ha realizzato una durata maggiore.</p>		

Tutte le info di cui hai bisogno sul nostro sito e sulle App!

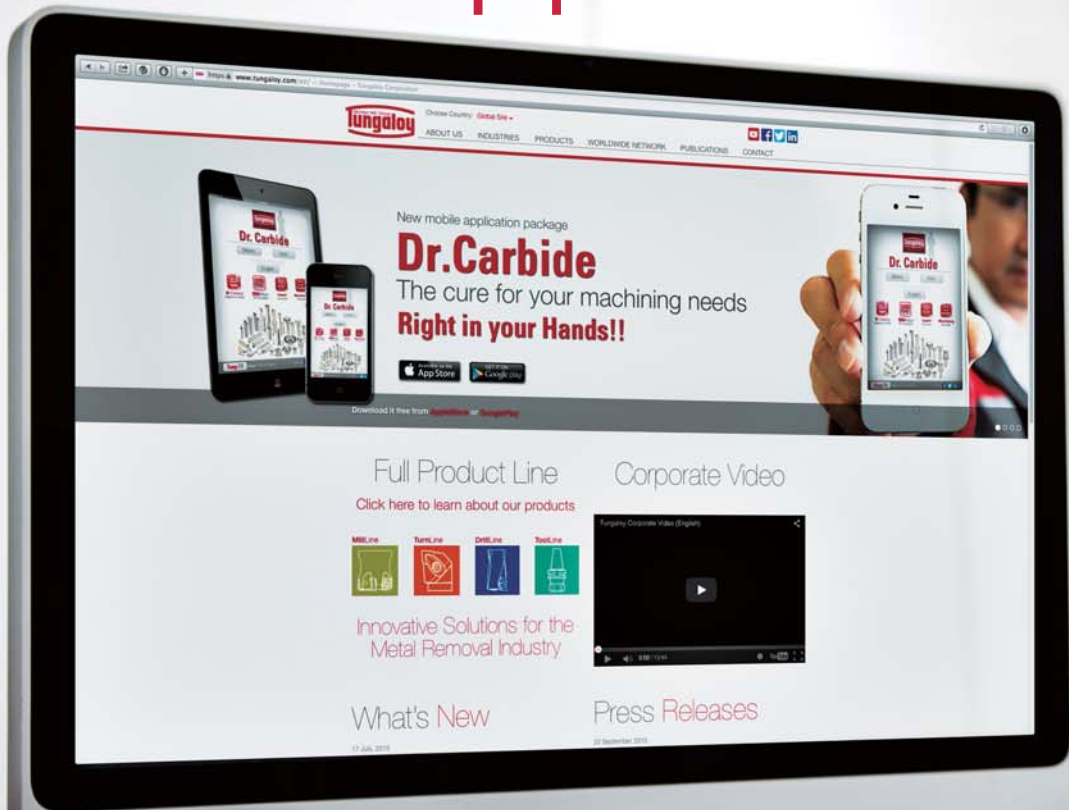

Available on the App Store



GET IT ON Google play

Tungaloy Corporation (Head office)

11-1 Yoshima-Kogyodanchi
Iwaki-city, Fukushima, 970-1144 Japan
Phone: +81-246-36-8501
Fax: +81-246-36-8542
www.tungaloy.co.jp

Tungaloy Italia S.r.l.

Via E. Andolfato 10
I-20126 Milano, Italy
Phone: +39-02-252012-1
Fax: +39-02-252012-65
www.tungaloy.it

Tungaloy America, Inc.

3726 N Ventura Drive
Arlington Heights, IL 60004, U.S.A.
Phone: +1-888-554-8394
Fax: +1-888-554-8392
www.tungaloyamerica.com

Tungaloy Canada

432 Elgin St. Unit 3
Brantford, Ontario N3S 7P7, Canada
Phone: +1-519-758-5779
Fax: +1-519-758-5791
www.tungaloy.co.jp/ca

Tungaloy de Mexico S.A.

C Los Arellano 113,
Parque Industrial Siglo XXI
Aguascalientes, AGS, Mexico 20290
Phone: +52-449-929-5410
Fax: +52-449-929-5411
www.tungaloy.co.jp/mx

Tungaloy do Brasil Ltda.

Rua dos Sabias N.104
13280-000 Vinhedo, São Paulo, Brazil
Phone: +55-19-38262757
Fax: +55-19-38262757
www.tungaloy.com/br

Tungaloy Germany GmbH

An der Alten Ziegelei 1
D-40789 Monheim, Germany
Phone: +49-2173-90420-0
Fax: +49-2173-90420-19
www.tungaloy.de

Tungaloy France S.A.S.

ZA Courtaboeuf - Le Rio
1 rue de la Terre de feu
F-91952 Courtaboeuf Cedex, France
Phone: +33-1-6486-4300
Fax: +33-1-6907-7817
www.tungaloy.fr

Tungaloy Czech s.r.o.

Turanka 115
CZ-627 00 Brno, Czech Republic
Phone: +420-532 123 391
Fax: +420-532 123 392
www.tungaloy.cz

Tungaloy Ibérica S.L.

C/Miquel Servet, 43B, Nau 7
Pol. Ind. Bufalvent
ES-08243 Manresa (BCN), Spain
Phone: +34 93 113 1360
Fax: +34 93 876 2798
www.tungaloy.es

Tungaloy Scandinavia AB

S:t Lars Väg 42A
SE-22270 Lund, Sweden
Phone: +46-462119200
Fax: +46-462119207
www.tungaloy.se

Tungaloy Rus, LLC

36-D Harkovsky Lane
308009 Belgorod, Russia
Phone: +7 4722 24 00 07
Fax: +7 4722 24 00 08
www.tungaloy.co.jp/ru

Tungaloy East LLC

Stachek str., h.4, office 2, Ekaterinburg,
620017, Russia
Phone: +7-343-389-13-22
Fax: +7-343-278-94-35
www.tungaloy.co.jp/ru

Tungaloy Polska Sp. z o.o.

ul. Genewska 24
03-963 Warszawa, Poland
Phone: +48-22-617-0890
Fax: +48-22-617-0890
www.tungaloy.co.jp/pl

Tungaloy U.K. Ltd

The Technology Centre,
Wolverhampton Science Park
Glaisher Drive, Wolverhampton
West Midlands WV10 9RU, UK
Phone: +44 121 4000 231
Fax: +44 121 270 9694
www.tungaloy.co.jp/uk
salesinfo@tungaloyuk.co.uk

Tungaloy Hungary Kft

Erzsébet királyné útja 125
H-1142 Budapest, Hungary
Phone: +36 1 781-6846
Fax: +36 1 781-6866
www.tungaloy.co.jp/hu
info@tungaloytools.hu

Tungaloy Turkey

Dudullu, OSB 4. Cad No:4
34776 Umraniye Istanbul, TURKEY
Phone: +90 216 540 04 67
Fax: +90 216 540 04 87
www.tungaloy.com.tr
info@tungaloy.com.tr

Tungaloy Benelux b.v.

Tjalk 70
NL-2411 NZ Bodegraven, Netherlands
Phone: +31 172 630 420
Fax: +31 172 630 429
www.tungaloy-benelux.com

Tungaloy Croatia

Josipa Kozarca 4
10432 Bregana, Croatia
Phone: +385 1 3326 604
Fax: +385 1 3327 683
www.tungaloy.hr

Tungaloy Cutting Tool (Shanghai) Co., Ltd.

Rm No 401 No.88 Zhabei
Jiangchang No.3 Rd
Shanghai 200436, China
Phone: +86-21-3632-1880
Fax: +86-21-3621-1918
www.tungaloy.co.jp/tots

Tungaloy Cutting Tool (Thailand) Co., Ltd.

Interlink tower 4th Fl.
1858/5-7 Bangna-Trad Road
km.5 Bangna, Bangna, Bangkok 10260
Thailand
Phone: +66-2-751-5711
Fax: +66-2-751-5715
www.tungaloy.co.th

Tungaloy Singapore (Pte.), Ltd.

62 Ubi Road 1, #06-11 Oxley BizHub 2
Singapore 408734
Phone: +65-6391-1833
Fax: +65-6299-4557
www.tungaloy.co.jp/tspl

Tungaloy Vietnam

Unit 18, 4th Fl. Saigon Centre Building
65 Le Loi Blvd.
Dist 1, Ho Chi Minh City, Vietnam
Phone: +84-8-3827-0201
Fax: +84-8-3827-0203
www.tungaloy.co.jp/tspl

Tungaloy India Pvt. Ltd.

Indiabulls Finance Centre,
Unit # 902-A, 9th Floor,
Tower 1, Senapati Bapat Marg,
Elphinstone Road (West),
Mumbai-400013, India
Phone: +91-22-6124-8804
Fax: +91-22-6124-8899
www.tungaloy.co.jp/in

Tungaloy Korea Co., Ltd

#1312, Byucksan Digital Valley 5-cha
Beotkkot-ro 244, Geumcheon-gu
153-788 Seoul, Korea
Phone: +82-2-2621-6161
Fax: +82-2-6393-8952
www.tungaloy.co.jp/kr

Tungaloy Malaysia Sdn Bhd

50 K-2, Kelana Mall, Jalan SS6/14
Kelana Jaya, 47301
Petaling Jaya, Selangor Darul Ehsan
Malaysia
Phone: +603-7805-3222
Fax: +603-7804-8563
www.tungaloy.co.jp/my

Tungaloy Australia Pty Ltd

PO Box 2232, Rowville,
Victoria 3178, Australia
Phone: +61-3-9755-8147
Fax: +61-3-9755-6070
www.tungaloy.com.au

PT. Tungaloy Indonesia

Kompleks Grand Wisata Block AA-10 No.3-5
Cibitung
Bekasi 17510, Indonesia
Phone: +62-21-8261-5808
Fax: +62-21-8261-5809
www.tungaloy.co.jp/id



www.tungaloy.it

seguici su:

facebook.com/tungaloyjapan

twitter.com/tungaloyjapan

Vuoi vedere questo prodotto in azione?

Visita:

Tung-TV

www.youtube.com/tungaloycorporation

Distribuito da:



SCARICA
Dr. Carbide
Tungaloy



Available on the
App Store



GET IT ON
Google play



ISO 9001 Certified
QC00J0056
Tungaloy Corporation
18/10/1996

ISO 14001 Certified
EC97J1123
Tungaloy Group
Japan site and Asian
production site
26/11/1997