



For more information

Shoulder milling cutter

TUNG-TRI

Tungaloy Report No. 421S3-US

Square shoulder milling cutters featuring economical inserts with 3 cutting edges — **Expansion of cutter body lineup for insert size 10**



TPA10

Square shoulder milling, bore type cutter with screw-on system

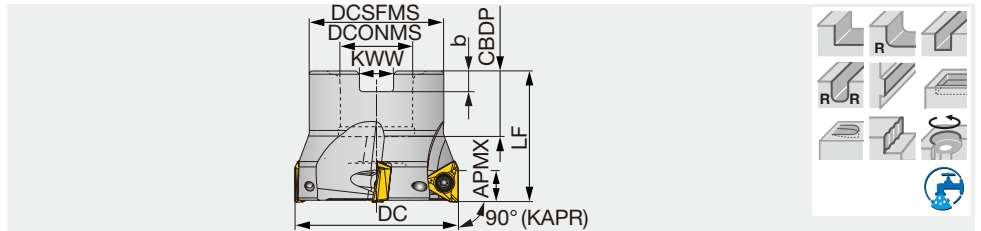

GAMP = +9.5° ~ +11°, GAMF = -4.5° ~ -0.5°

Inch	APMX	DC	CICT	DCSFMS	DCONMS	CBDP	LF	b	KWW	WT(lb)	Air Hole	Insert	Arbor Type
TPA10R150U0050A04	0.394	1.500	4	1.378	0.500	0.610	1.575	0.157	0.258	0.400	with	TO*T10...	A
New TPA10R150U0050A05	0.394	1.500	5	1.378	0.500	0.630	1.575	0.157	0.258	0.490	with	TO*T10...	A
TPA10R200U0075A04	0.394	2.000	4	1.693	0.750	0.750	1.575	0.197	0.315	0.770	with	TO*T10...	A
New TPA10R200U0075A05	0.394	2.000	5	1.693	0.750	0.750	1.575	0.197	0.315	0.790	with	TO*T10...	A
TPA10R250U0075A06	0.394	2.500	6	1.693	0.750	0.750	1.575	0.197	0.315	1.060	with	TO*T10...	A
TPA10R300U0100A07	0.394	3.000	7	2.283	1.000	1.024	1.969	0.236	0.374	2.100	with	TO*T10...	A
TPA10R400U0150A08	0.394	4.000	8	3.150	1.500	1.413	2.480	0.394	0.626	4.100	with	TO*T10...	B

SPARE PARTS

Designation	Clamping screw	Grip	Torx bit	Lubricant	Shell locking bolt (optional parts)
TPA10R150U...	SR14-562/S	SW6-SD	BLDT10/S7	M-1000	(SF UNF 1/4x3/4 B18.3)
TPA10R200U... - 250U...	SR14-562/S	SW6-SD	BLDT10/S7	M-1000	(C0.375X1.125H)
TPA10R300U0100A07	SR14-562/S	SW6-SD	BLDT10/S7	M-1000	(C0.500X1.375H)
TPA10R400U0150A08	SR14-562/S	SW6-SD	BLDT10/S7	M-1000	(TMBA-0.750H)

*Recommended clamping torque : SR14-562/S = 2.58 (lbs-ft)

Arbor type

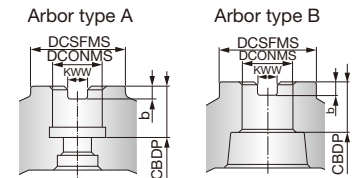

APPLICATION RANGE

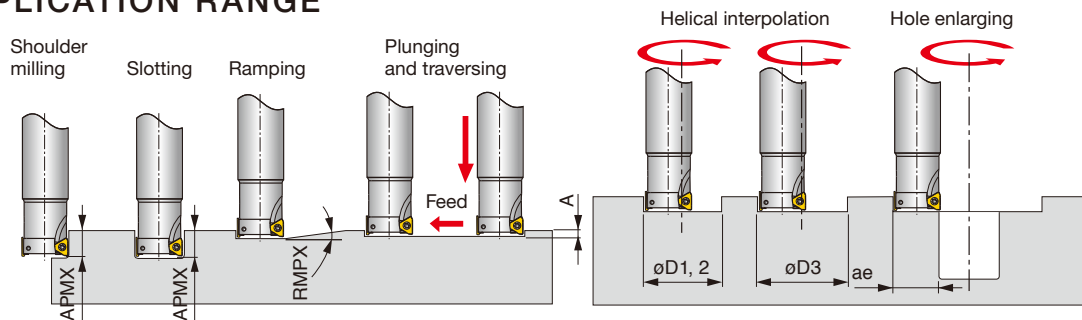

Designation	DC (in)	Max. depth of cut APMX (in)	Max. ramping angle RMPX	Max. plunging depth A (in)	Min. machining diameter øD1 (in)	Max. machining diameter øD2 (in)	Max. machining diameter øD3* (in)	Max. cutting width in enlarging ae (in)
New TPA10R150U...	1.500	0.394	1.4°	0.024	2.689	2.984	2.882	1.48
New TPA10R200U...	2.000	0.394	0.8°	0.024	3.689	3.984	3.882	1.98
TPA10R250U...	2.500	0.394	0.7°	0.024	4.689	4.984	4.882	2.48
TPA10R300U...	3.000	0.394	0.6°	0.024	5.689	5.984	5.882	2.98
TPA10R400U...	4.000	0.394	0.5°	0.024	7.689	7.984	7.882	3.98

* Flat bottom hole

Note: Corner RE for dimensions of øD1, øD2 and øD3: RE = 0.016" for TPA10.



tungaloy.com/us
follow us at:
facebook.com/tungaloyamerica
instagram.com/tungaloyamerica
linkedin.com/company/tungaloy-america

To see Tungaloy products in action visit:



www.youtube.com/tungaloycorporation

Distributed by:



Tungaloy APP & SNS

FIND US ON THE CLOUD!
machingcloud.com



AS9100 Certified
78006
2015.11.04
ISO 14001 Certified
EC97J1123
1997.11.26