



For more information

Exchangeable head drill

**DRILLMEISTER**

Tungaloy Report No. 412S12-G

## New TID modular drill bodies with chamfering inserts

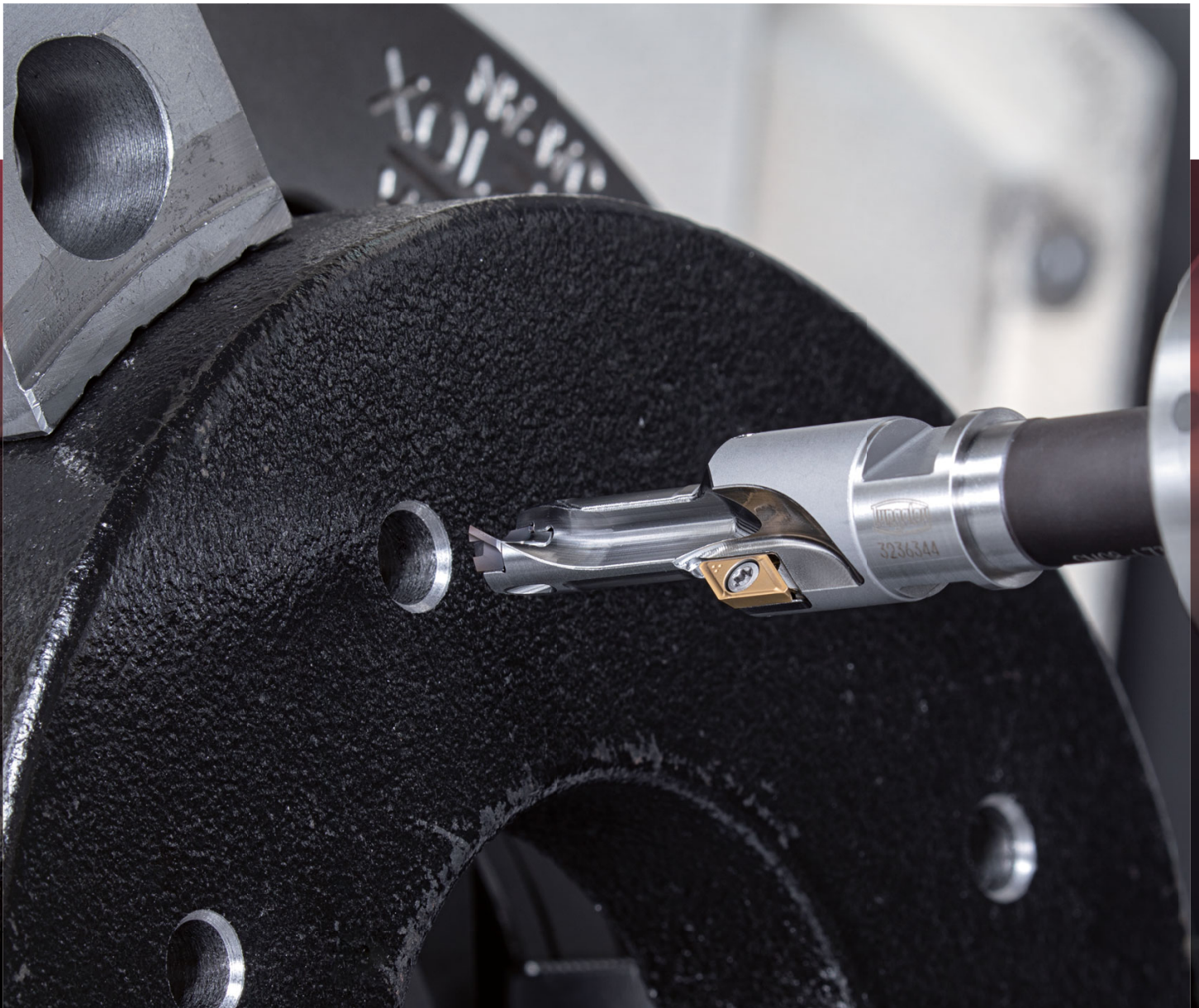

## ■ Drill body with chamfering insert with a TungFlex connection

- Drilling and chamfering can be done by one tool
- Dedicated line up for pre-thread drilling of metric and UNF threads
- Stable chamfering capability with less chattering due to dedicate insert design for chamfering
- Easy to extend tool overhang by combination with existing TungFlex shanks

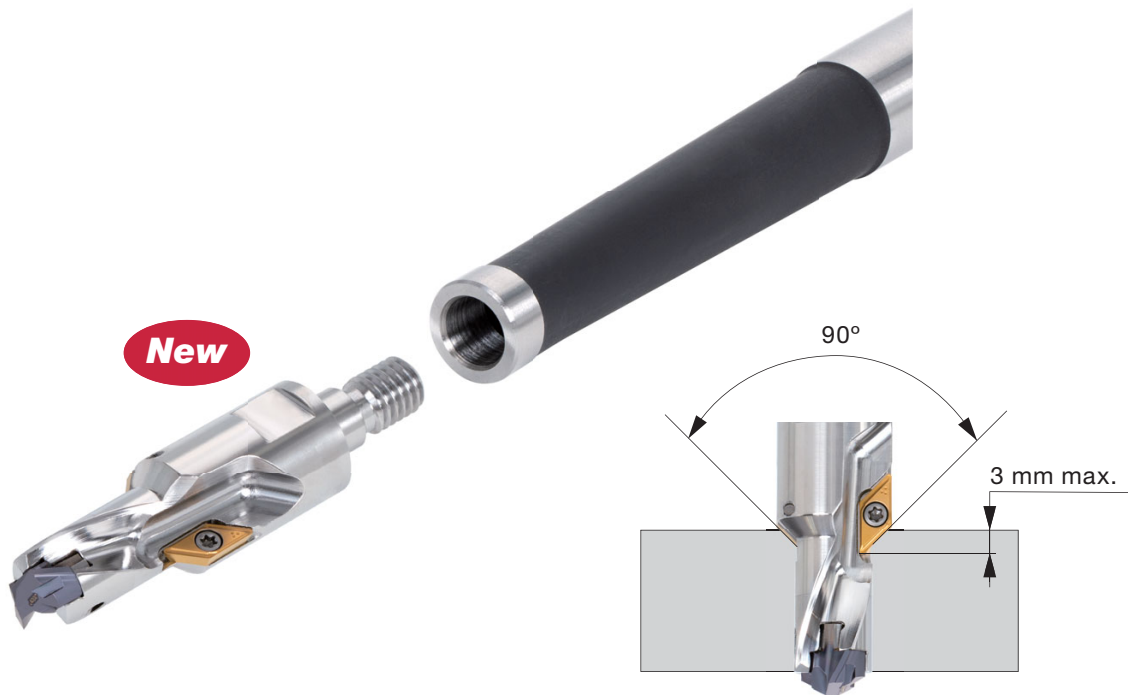

## Tools line up per relative thread size

Designation	Thread		
TID065L25A90M08	M7X0.5	M8X1.25	5/16 - 18UNF
TID085L25A90M08	M10X1.5	M10X1.25	3/8 - 24UNF
TID100L25A90M10	M11X1.0	M11X0.75	M12X1.75
TID105L25A90M10	M12X1.5	M12X1.25	1/2 - 13UNF
TID120L25A90M10, TID120L40A90M10	M14X2.0	9/16 - 12UNF	-
TID125L25A90M10, TID125L40A90M10	M14X1.5	9/16 - 18UNF	-
TID140L25A90M12, TID140L40A90M12	M16X2.0	-	-
TID145L25A90M12, TID145L40A90M12	M16X1.5	5/8 - 18UNF	-
TID150L25A90M12, TID150L40A90M12	M16X1.0	M17X1.5	-
TID160L25A90M12, TID160L40A90M12	M18X1.5	3/4 - 10UNF	M17X1.0

## Designation

**TID** **100** **L** **25** **A** **90** **M10**

1 Drill diameter: 100, ø10

2 Step length: 25, 25 mm

3 Chamfer angle: 90, 90°

4 Modular thread size

Note: Drill head diameter can be changed within the same pocket size. Please check the dimension table.

## MODULAR BODIES

New

### TID-L-A-M

Drill with chamfer and "TungFlex" connection

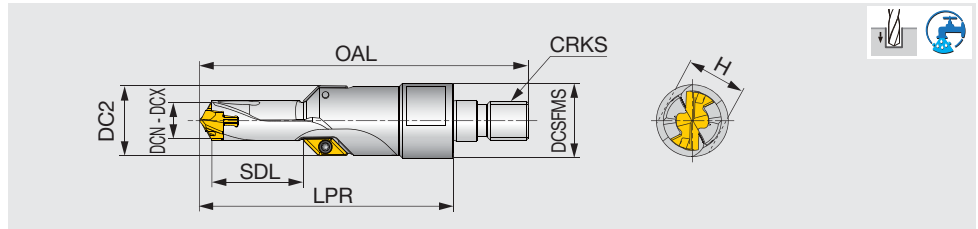

Designation	DCX	DCN	DC2	SDL	DCSFMS	LPR	OAL	CRKS	H	Pocket size
TID065L25A90M08	6.9	6.5	13.84	24.91	15.5	58.18	75.18	M8	10	6.5
TID085L25A90M08	8.9	8.5	15.84	25	15.5	58.29	75.29	M8	10	8
TID100L25A90M10	10.4	10	17.34	25	19	64.47	83.47	M10	15	10
TID105L25A90M10	10.9	10.5	19.34	25	19	64.56	83.56	M10	15	10
TID120L25A90M10	12.4	12	19.34	25	19	64.82	83.82	M10	15	12
TID120L40A90M10	12.4	12	19.34	40	19	79.82	98.82	M10	15	12
TID125L25A90M10	12.9	12.5	19.84	25	19	64.91	83.91	M10	15	12
TID125L40A90M10	12.9	12.5	19.84	40	19	79.91	98.91	M10	15	12
TID140L25A90M12	14.4	14	21.34	25	23.5	70.12	92.12	M12	17	14
TID140L40A90M12	14.4	14	21.34	40	23.5	85.12	107.12	M12	17	14
TID145L25A90M12	14.9	14.5	21.84	25	23.5	70.21	92.21	M12	17	14
TID145L40A90M12	14.9	14.5	21.84	40	23.5	85.21	107.21	M12	17	14
TID150L25A90M12	15.9	15	22.34	25	23.5	70.27	92.27	M12	17	15
TID150L40A90M12	15.9	15	22.34	40	23.5	85.27	107.27	M12	17	15
TID160L25A90M12	16.9	16	23.34	25	23.5	70.42	92.42	M12	17	16
TID160L40A90M12	16.9	16	23.34	40	23.5	85.42	107.42	M12	17	16

Tool diameter	Hole diameter tolerance*
ø6.5 - ø16.9	+0.04 / 0

\*Just for reference

### SPARE PARTS

Designation	Clamping key	Wrench	Clamping screw
TID065L... - TID085L...	K-TID6-9.99	T-7D	SR 34-508
TID100L... - TID160L...	K-TID10-19.99	T-7D	SR 34-508

## INSERT FOR CHAMFERING

### AOMT...

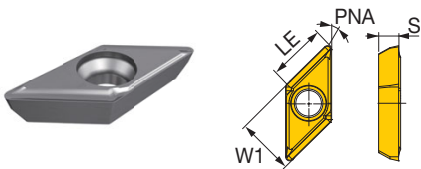

<b>P</b> Steel	★				
<b>M</b> Stainless	★				
<b>K</b> Cast iron	★				
<b>N</b> Non-ferrous	☆				
<b>S</b> Superalloys	★				
<b>H</b> Hard materials	★				

★ : First choice  
☆ : Second choice

Designation	LE	Chamfering angle PNA	Coated		W1	S
			GH730			
AOMT060204-C45	4.5	45°	●		5.66	1.96

● : Line up

## SHANKS

### SM

Steel modular shank

# TUNGFLEX

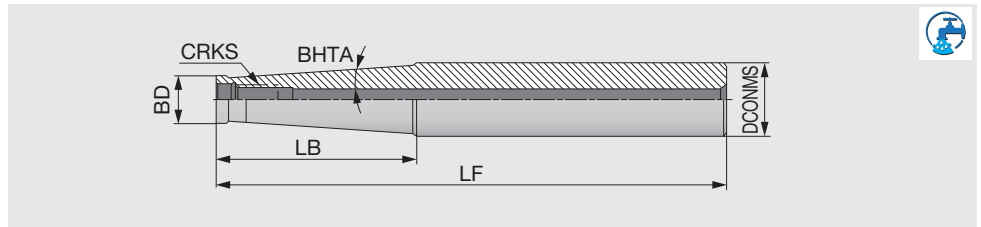

Designation	CRKS	DCONMS	LF	LB	BD	BHTA
SM08-L73C16	M8	16	73	25	13	0°
SM08-L128-C16	M8	16	128	80	13	0.9°
SM08-L170-C20	M8	20	170	66.8	13	3.3°
SM10-L80C20	M10	20	80	30	18	0°
SM10-L130-C20	M10	20	130	80	18	0.6°
SM10-L200-C25	M10	25	200	57.2	19	3.3°
SM12-L86-C25	M12	25	86	30	21	5.1°
SM12-L200-C32	M12	32	200	78	21	4.4°

e-catalog



## SM-C-H

Carbide modular shank

# TUNGFLEX

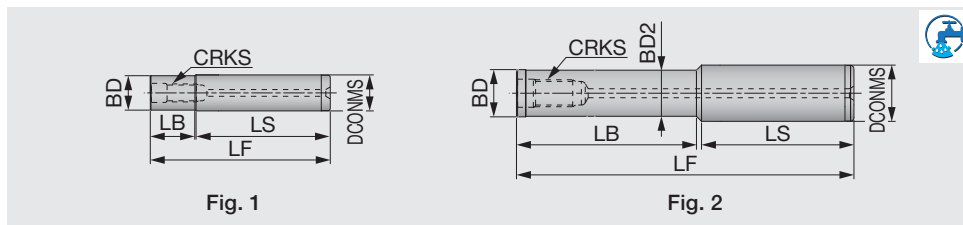

Designation	CRKS	DCONMS	LF	LB	LS	BD	BD2	Fig.
SM08-L80-20-C16-C-H	M8	16	80	20	59.6	15.3	-	1
SM08-L100-40-C16-C-H	M8	16	100	40	59.6	15.3	-	1
SM08-L150-80-C16-C-H	M8	16	150	80	69.6	15.3	-	1
SM08-L200-100-C16-C-H	M8	16	200	100	98.2	13	12.5	2
SM08-L200-140-C16-C-H	M8	16	200	140	59.6	15.3	-	1
SM08-L250-180-C16-C-H	M8	16	250	180	69.6	15.3	-	1
SM10-L80-20-C20-C-H	M10	20	80	20	59.2	18.5	-	1
SM10-L100-40-C20-C-H	M10	20	100	40	59.2	18.5	-	1
SM10-L150-80-C20-C-H	M10	20	150	80	69.2	18.5	-	1
SM10-L200-100-C20-C-H	M10	20	200	100	99.2	18.5	-	1
SM10-L200-140-C20-C-H	M10	20	200	140	58.7	18	17.5	2
SM10-L200-140-C20-C-H-N	M10	20	200	140	59.2	18.5	-	1
SM10-L250-130-C20-C-H	M10	20	250	130	118.7	18	17.5	2
SM10-L250-180-C20-C-H	M10	20	250	180	68.7	18	17.5	2
SM10-L250-180-C20-C-H-N	M10	20	250	180	69.2	18.5	-	1
SM10-L300-180-C20-C-H	M10	20	300	180	118.7	18	17.5	2
SM10-L300-230-C20-C-H	M10	20	300	230	68.7	18	17.5	2
SM12-L100-40-C25-C-H	M12	25	100	40	59.5	24	-	1
SM12-L150-80-C25-C-H	M12	25	150	80	67.7	21	20.5	2
SM12-L150-80-C25-C-H-N	M12	25	150	80	69.5	24	-	1
SM12-L200-100-C25-C-H	M12	25	200	100	97.7	21	20.5	2
SM12-L200-100-C25-C-H-N	M12	25	200	100	99.5	24	-	1
SM12-L200-140-C25-C-H	M12	25	200	140	57.7	21	20.5	2
SM12-L250-130-C25-C-H	M12	25	250	130	117.7	21	20.5	2
SM12-L250-180-C25-C-H	M12	25	250	180	69.5	24	-	1
SM12-L300-180-C25-C-H	M12	25	300	180	117.7	21	20.5	2
SM12-L300-180-C25-C-H-N	M12	25	300	180	119.5	24	-	1
SM12-L300-230-C25-C-H	M12	25	300	230	67.7	21	20.5	2

e-catalog



## STANDARD CUTTING CONDITIONS

ISO	Workpiece material	Cutting speed Vc (m/min)	Feed: f (mm/rev)					
			Tool diameter: DC (mm)					
			ø6 - 7.9	ø8 - 9.9	ø10 - ø11.9	ø12 - ø13.9	ø14 - ø15.9	ø16 - ø16.9
<b>P</b>	Low carbon steels (C < 0.3) SS400, SM490, S25C, etc. C15E4, E275A, E355D, etc.	80 - 140	0.09 - 0.13	0.12 - 0.25	0.15 - 0.28	0.18 - 0.3	0.2 - 0.35	0.25 - 0.45
	High carbon steels (C > 0.3) S45C, S55C, etc. C45, C55, etc.	70 - 120	0.09 - 0.13	0.12 - 0.25	0.15 - 0.28	0.18 - 0.3	0.2 - 0.35	0.25 - 0.45
	Low alloy steels SCM415, etc. 18CrMo4, etc.	70 - 120	0.08 - 0.13	0.11 - 0.25	0.14 - 0.28	0.16 - 0.32	0.18 - 0.35	0.23 - 0.4
	Alloy steels SCM440, SCr420, etc. 42CrMo4, 20Cr4, etc.	40 - 90	0.08 - 0.13	0.11 - 0.25	0.14 - 0.28	0.16 - 0.32	0.18 - 0.35	0.23 - 0.4
<b>M</b>	Stainless steels SUS304, SUS316, etc. X5CrNi18-9, X5CrNiMo17-12-2, etc.	30 - 70	0.08 - 0.1	0.1 - 0.15	0.12 - 0.18	0.14 - 0.2	0.16 - 0.24	0.16 - 0.26
<b>K</b>	Grey cast irons FC250, etc. GG25, etc.	80 - 180	0.12 - 0.18	0.15 - 0.3	0.20 - 0.35	0.25 - 0.4	0.3 - 0.45	0.35 - 0.55
	Ductile cast irons FCD700, etc. GGG70, etc.	80 - 140	0.12 - 0.18	0.15 - 0.3	0.20 - 0.35	0.25 - 0.4	0.3 - 0.45	0.35 - 0.55
<b>N</b>	Aluminium alloys ADC12, etc. AlSi11Cu3, etc.	80 - 220	0.1 - 0.2	0.2 - 0.35	0.25 - 0.4	0.3 - 0.45	0.35 - 0.5	0.4 - 0.6
<b>S</b>	Titanium alloys Ti-6Al-4V, etc.	20 - 50	0.05 - 0.07	0.06 - 0.12	0.08 - 0.15	0.1 - 0.28	0.12 - 0.2	0.14 - 0.22
	Nickel-based alloys	20 - 50	0.05 - 0.07	0.06 - 0.11	0.08 - 0.13	0.1 - 0.15	0.12 - 0.18	0.12 - 0.22
<b>H</b>	Hardened steel	20 - 50	0.05 - 0.07	0.06 - 0.12	0.08 - 0.15	0.1 - 0.18	0.12 - 0.2	0.14 - 0.22

- Use the above cutting data for reference. Adjust the data according to the machine rigidity, capability, and the workpiece material being machined.  
 - Machine tool rigidity and/or cutting parameters being used in the operation may influence the accuracy of the hole sizes and quality.

Machining stability changes depending on the amount of chamfering.

Adjust the cutting feed based on the table below during chamfer edge contact to work piece.

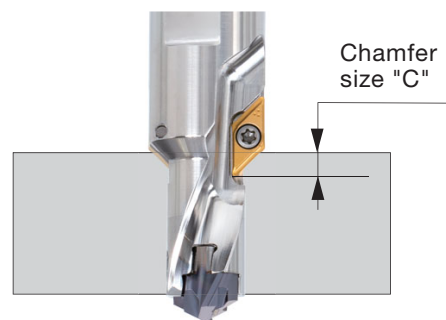
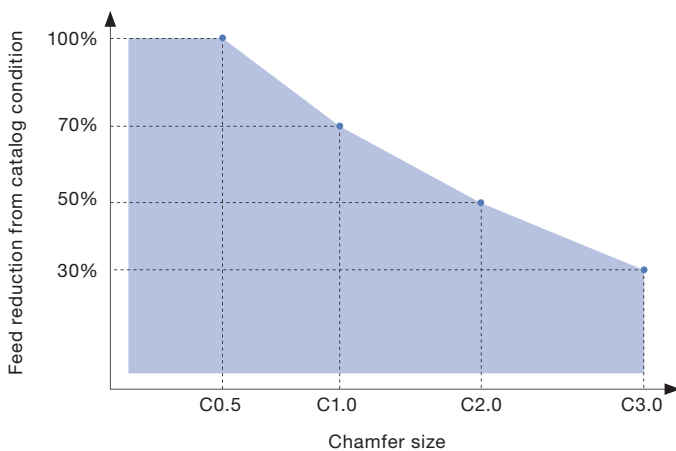

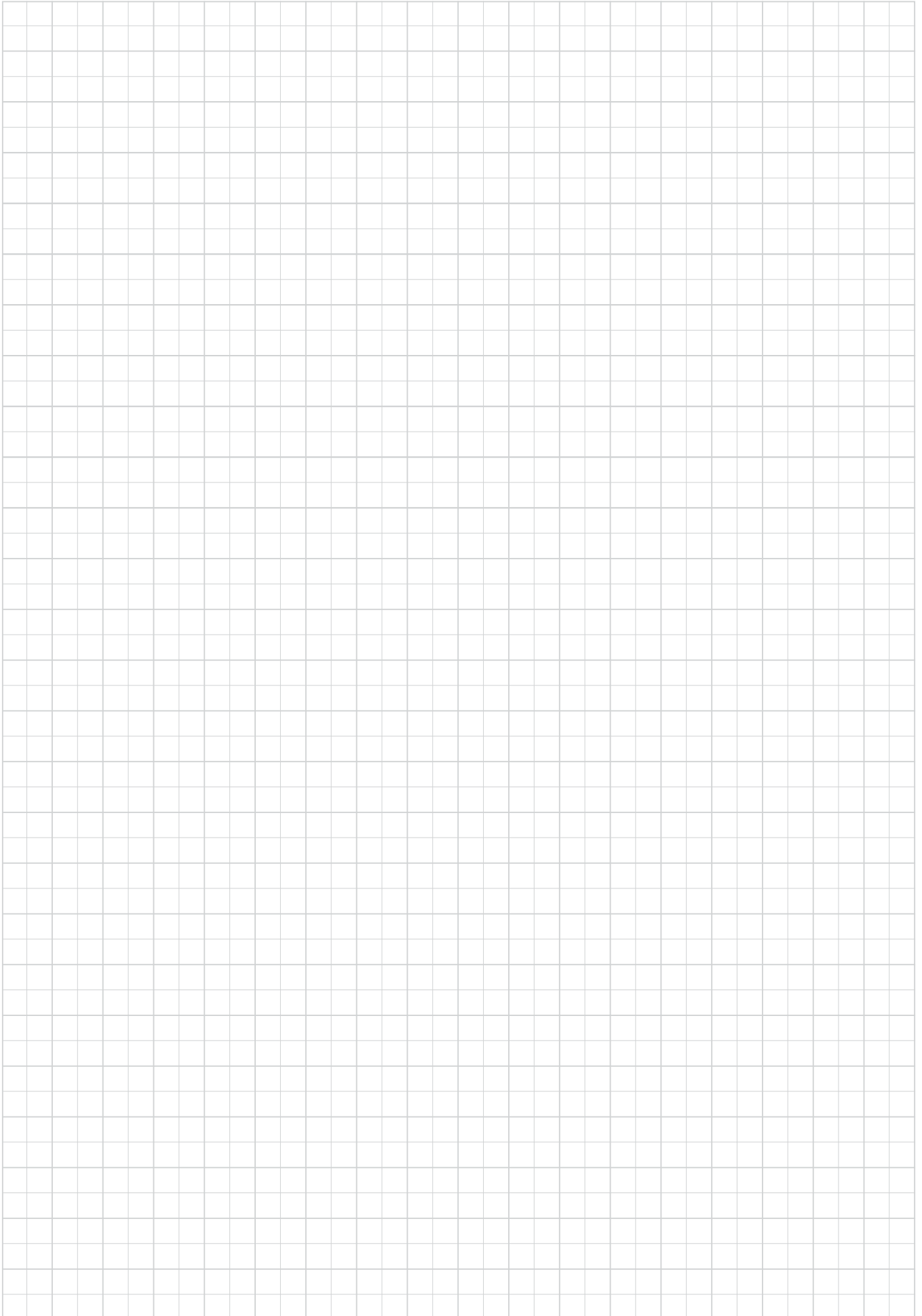

# MEMO

A large grid of graph paper, consisting of 30 columns and 40 rows of small squares, intended for writing notes or taking a memo.

### **Tungaloy Corporation (Head office)**

11-1 Yoshima-Kogyodanchi  
Iwaki-city, Fukushima 970-1144 Japan  
Phone: +81-246-36-8501  
Fax: +81-246-36-8542  
www.tungaloy.co.jp

### **Tungaloy-NTK America Inc.**

3726 N Ventura Drive  
Arlington Heights, IL 60004, U.S.A.  
Phone: +1-888-554-8394  
Fax: +1-888-554-8392  
www.tungaloy.com/us

### **Tungaloy Canada**

432 Elgin St. Unit 3  
Brantford, Ontario N3S 7P7, Canada  
Phone: +1-519-758-5779  
Fax: +1-519-758-5791  
www.tungaloy.com/ca

### **Tungaloy-NTK De Mexico S.A.**

C. Los Arellano 113,  
Parque Industrial Siglo XXI  
Aguascalientes, AGS, Mexico 20290  
Phone: +52-449-929-5410  
Fax: +52-449-929-5411  
www.tungaloy.com/mx

### **Tungaloy-NTK do Brasil Ltda.**

Avd. Independencia N4158 Residencial Flora  
13280-000 Vinhedo, São Paulo, Brasil  
Phone: +55-19-38262757  
Fax: +55-19-38262757  
www.tungaloy.com/br

### **Tungaloy-NTK Germany GmbH.**

Katzbergstr. 3a  
D-40764 Langenfeld, Germany  
Phone: +49-2173-90420-0  
Fax: +49-2173-90420-19  
www.tungaloy.com/de

### **Tungaloy France s.a.s**

Les Fjords  
19 avenue de Norvège  
91140 Villebon Sur Yvette, France  
Phone: +33-1-6486-4300  
Fax: +33-1-6907-7817  
www.tungaloy.com/fr

### **Tungaloy Italia S.r.l.**

Via E. Andolfato 10  
I-20126 Milano, Italy  
Phone: +39-02-252012-1  
Fax: +39-02-252012-65  
www.tungaloy.com/it

### **Tungaloy Czech s.r.o.**

Turanka 115  
CZ-627 00 Brno, Czech Republic  
Phone: +420-532 123 391  
Fax: +420-532 123 392  
www.tungaloy.com/cz

### **Tungaloy Ibérica S.L.**

C/Miquel Servet, 43B, Nau 7  
Pol. Ind. Bufalvent  
ES-08243 Manresa (BCN), Spain  
Phone: +34 93 113 1360  
Fax: +34 93 876 2798  
www.tungaloy.com/es

### **Tungaloy Scandinavia AB**

Bultgatan 38  
442 40 Kungälv, Sweden  
Phone: +46-462119200  
Fax: +46-462119207  
www.tungaloy.com/se

### **Tungaloy Rus, LLC**

Andropova avenue, h.18/7,  
11 floor, office 3, 115432,  
Moscow, Russia  
Phone: +7-499-683-01-80  
Fax: +7-499-683-01-81  
www.tungaloy.com/ru

### **Tungaloy Polska Sp. z o.o.**

Ul. Irysowa 1, 55-040 Bielany  
Wroclawskie, Poland  
Phone: +48 607 907 237  
www.tungaloy.com/pl

### **Tungaloy-NTK UK Ltd.**

Suite 3, Pioneer House, Mill Street,  
Cannock, WS11 0EF, UK  
Phone: +44 121 4000 231  
Fax: +44 121 270 9694  
www.tungaloy.com/uk

### **Tungaloy Hungary Kft**

Erzsébet királyné útja 125  
H-1142 Budapest, Hungary  
Phone: +36 1 781-6846  
Fax: +36 1 781-6866  
www.tungaloy.com/hu

### **Tungaloy Turkey**

Serifali Mah.bayraktar Bulvari Kule Sk. No:26  
34775 Umraniye / Istanbul / Turkey  
Phone: +90 216 540 04 67  
Fax: +90 216 540 04 87  
www.tungaloy.com/tr

### **Tungaloy Benelux b.v.**

Tjalk 70  
NL-2411 NZ Bodegraven, Netherlands  
Phone: +31 172 630 420  
Fax: +31 172 630 429  
www.tungaloy.com/nl

### **Tungaloy Croatia**

Ulica bana Josipa Jelačića 87,  
10430, Samobor, Croatia  
Phone: +385 1 3326 604  
Fax: +385 1 3327 683  
www.tungaloy.com/hr

### **Tungaloy Cutting Tool (Shanghai) Co. Ltd.**

Rm No 401 No.88 Zhabei  
Jiangchang No.3 Rd  
Shanghai 200436, China  
Phone: +86-21-3632-1880  
Fax: +86-21-3621-1918  
www.tungaloy.com/cn

### **Tungaloy Cutting Tools Taiwan Co. Ltd.**

9F, No.293, Zhongyang Rd,  
Xinzhuan Dist, New Taipei City,  
24251 Taiwan  
Phone: +886-2-8521-9986  
Fax: +886-2-8521-8935  
www.tungaloy.com/tw

### **Tungaloy-NTK Cutting Tool (Thailand) Co.,Ltd.**

Interlink tower 4th Fl.  
1858/5-7 Bangna-Trad Road  
km.5 Bangna, Bangna, Bangkok 10260  
Thailand  
Phone: +66-2-751-5711  
Fax: +66-2-751-5715  
www.tungaloy.com/th

### **Tungaloy Singapore (Pte.), Ltd.**

62 Ubi Road 1, #06-11 Oxley BizHub 2  
Singapore 408734  
Phone: +65-6391-1833  
Fax: +65-6299-4557  
www.tungaloy.com/sg

### **Tungaloy Vietnam**

LE04.38, Lexington Residence  
67 Mai Chi Tho St., Dist. 2,  
Ho Chi Minh City, Vietnam  
Phone: +84-2837406660  
www.tungaloy.com/sg

### **Tungaloy India Pvt. Ltd.**

One International Center,  
Unit # 902-A, 9th Floor,  
Tower 1, Senapati Bapat Marg,  
Elphinstone Road (West),  
Mumbai 400013, India  
Phone: +91-22-6124-8803  
Fax: +91-22-6124-8899  
www.tungaloy.com/in

### **Tungaloy Korea Co., Ltd**

#1312, Byucksan Digital Valley 5-cha  
Beotkkot-ro 244, Geumcheon-gu  
153-788 Seoul, Korea  
Phone: +82-2-2621-6161  
Fax: +82-2-6393-8952  
www.tungaloy.com/kr

### **Tungaloy Malaysia Sdn Bhd**

50 K-2, Kelana Mall, Jalan SS6/14  
Kelana Jaya, 47301  
Petaling Jaya, Selangor Darul Ehsan  
Malaysia  
Phone: +603-7805-3222  
Fax: +603-7804-8563  
www.tungaloy.com/my

### **Tungaloy Australia Pty Ltd**

Unit 68 1470 Ferntree Gully Road  
Knoxfield 3180 Victoria, Australia  
Phone: +61-3-9755-8147  
Fax: +61-3-9755-6070  
www.tungaloy.com/au

### **PT. Tungaloy Indonesia**

Ruko Blok AA.10 No3&5, Grand Wisata,  
Lambangjaya, Tambun Selatan, Bekasi,  
17510 Indonesia  
Phone: +62-21-8261-5808  
Fax: +62-21-8261-5809  
www.tungaloy.com/id



**tungaloy.com**

follow us at:

facebook.com/tungaloyjapan

twitter.com/tungaloyjapan

www.youtube.com/tungaloycorporation

Distributed by:



Tungaloy APP & SNS

FIND US ON THE CLOUD!  
machingcloud.com



AS9100 Certified  
78006  
2015.11.04  
ISO 14001 Certified  
EC97J1123  
1997.11.26