



Tooling system

TUNGHYDRO

Tungaloy Report No. 389S6-G

Hydraulic chuck tool holders (T-series)

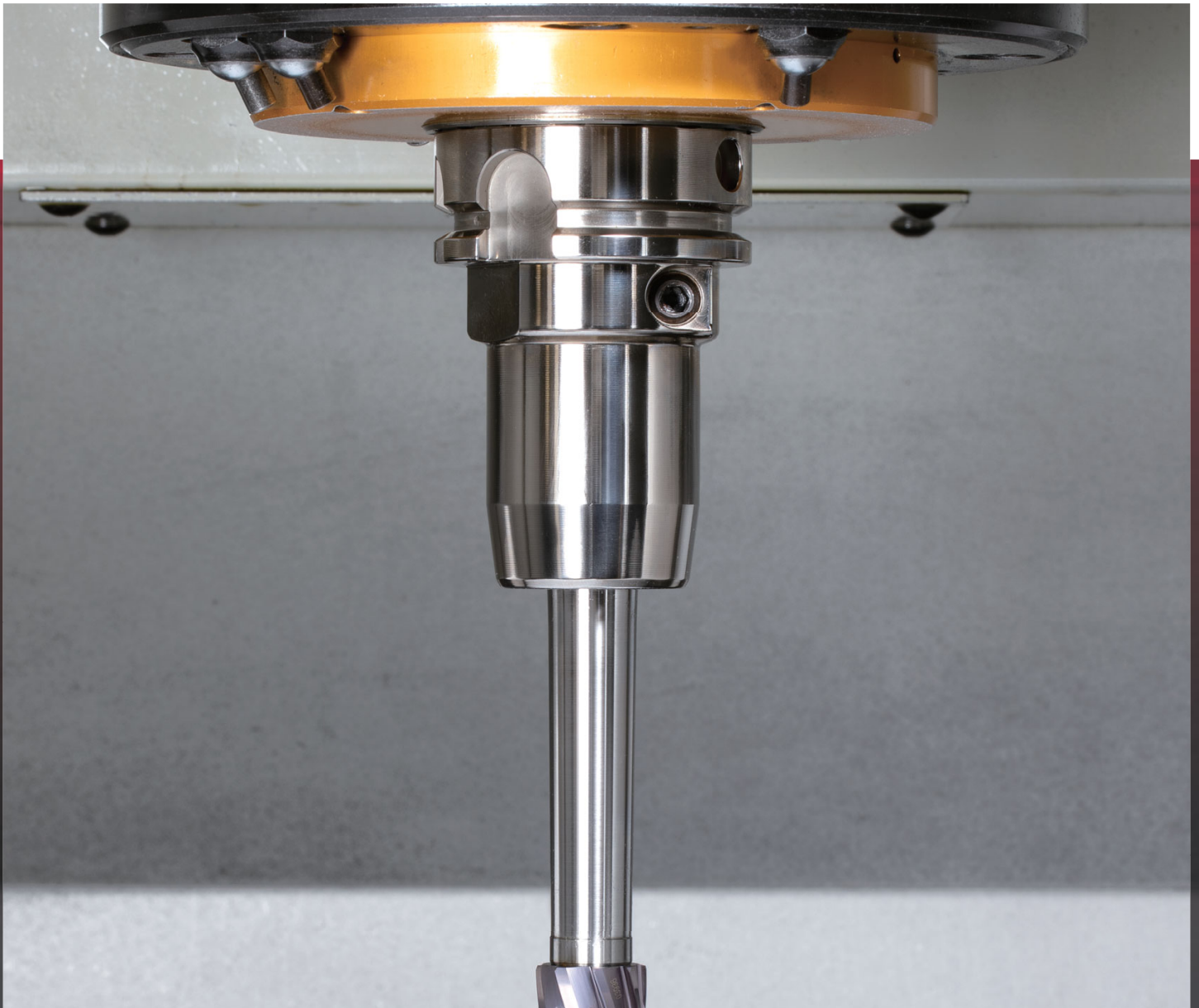

T series high-precision hydraulic chuck tool holders - supports a wide variety of machine interfaces

■ Features

- **Easy handling and high precision run out**

Simply turn the actuator screw with an Allen key to the dead stop to achieve high precision clamping with ≤ 0.003 mm run out accuracy.

- **High pull-out security and strong clamping torque for process stability**

- **Robust toolholder body design**

High radial rigidity prevents lateral tool deflection during machining, providing better part geometry accuracy.

- **Superior vibration damping**

Unique hydraulic system absorbs vibrations, assuring chatter-free machining and excellent workpiece surfaces, while eliminating tool breakage.



T series hydraulic system

1 Actuator screw

Can be operated without a torque wrench and features a unique safety stop that prevents over-tightening damage when the cutting tool is not in place.

2 Actuator piston

Compresses the hydraulic fluid into the chamber system.

3 Clamping sleeve and chamber system

The clamping sleeve expands against the tool shank. This clamping process first centers the tool shank before fully clamping it over the whole surface.

4 Tool holder body

Available with HSK, SK, CAT, and BT machine interfaces.

5 Length adjustment screw

For fast and easy presetting.

6 Groove

Creates a displacement of oil, grease, or lubricant residues into the groove, causing surfaces to remain dry.

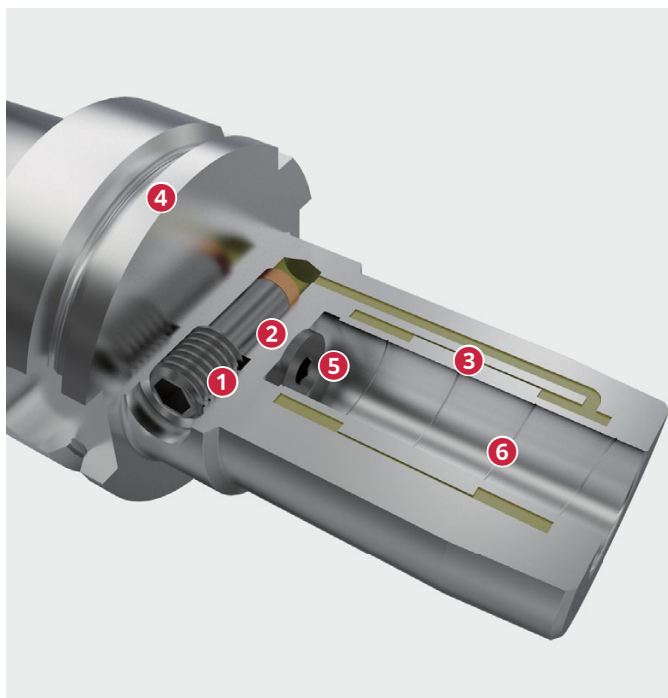

New

BT-HYDRO-T

BT MAS-403 ADB TungHydro hydraulic endmill chuck holders with BT shank

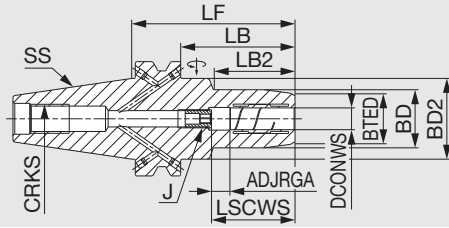

Designation	SS	DCONWS	BD	BD2	BTED	LF	LSCWS	ADJRGA	LB2	LB	J	Min. Torque (N-m)	WT(kg)	CRKS	Wrench*
BT30HYDRO6X55T	30	6	26	46	22.8	55	37	10	17.8		M5	16	0.6	M12	P-5
BT30HYDRO8X55T	30	8	28	46	24.8	55	37	10	18.4		M6	23	0.6	M12	P-5
BT30HYDRO10X55T	30	10	30	46	26.8	55	41	10	19		M8x1	45	0.6	M12	P-5
BT30HYDRO12X55T	30	12	32	46	28.8	55	46	10	19.5		M10x1	90	0.6	M12	P-5
BT30HYDRO16X90T	30	16	38	45	34.7	90	49	10	50	68	M12x1	185	0.9	M12	P-5
BT30HYDRO20X90T	30	20	42	45	37.7	90	51	10	50	68	M8x1	330	0.95	M12	P-5
BT40HYDRO6X90T	40	6	26	44.5	22	90	37	10	43	63	M5	16	1.4	M16	P-5
BT40HYDRO8X90T	40	8	28	44.5	24	90	37	10	44.5	63	M6	23	1.4	M16	P-5
BT40HYDRO10X90T	40	10	30	44.5	26	90	41	10	44.5	63	M8x1	45	1.4	M16	P-5
BT40HYDRO12X90T	40	12	32	44.5	28	90	46	10	44.5	63	M10x1	90	1.4	M16	P-5
BT40HYDRO16X90T	40	16	38	44.5	34	90	49	10	47.5	63	M12x1	185	1.5	M16	P-5
BT40HYDRO20X90T	40	20	42	44.5	38	90	51	10	47.5	63	M16x1	330	1.5	M16	P-5
BT40HYDRO32X100T	40	32	62	-	58.5	100	61	10	63	-	M16x1	650	2.55	M16	P-6
BT50HYDRO12X90T	50	12	32	49.25	28	90	46	10	31.5	52	M10x1	90	3.95	M24	P-5
BT50HYDRO20X90T	50	20	42	49.25	38	90	51	10	34	52	M16x1	330	3.95	M24	P-5
BT50HYDRO32X120T	50	32	64	70.25	60	120	61	10	62.5	82	M16x1	650	5.1	M24	P-6

* Wrench is not included. Please order separately.
Tool shank tolerance: h6
Balanced to G2.5, max n: 25,000 min⁻¹

New

HSK A-HYDRO-T

TungHydro hydraulic endmill chuck holders with DIN69893 HSK-A shank

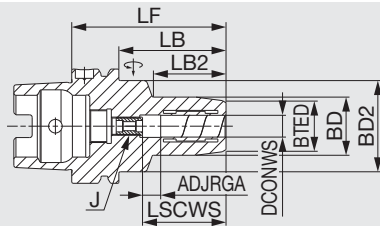

Designation	DCONWS	BD	BD2	BTED	LF	LSCWS	ADJRGA	LB2	LB	J	Min. Torque (N-m)	WT(kg)	Wrench*
HSKA63HYDRO6X70T	6	26	50	22	70	37	10	24	44	M5	16	1	P-5
HSKA63HYDRO8X70T	8	28	50	24	70	37	10	25	44	M6	23	1	P-5
HSKA63HYDRO10X80T	10	30	50	26	80	41	10	35	54	M8x1	45	1.1	P-5
HSKA63HYDRO12X85T	12	32	50	28	85	46	10	40	59	M10x1	90	1.1	P-5
HSKA63HYDRO16X90T	16	38	50	34	90	49	10	46	64	M12x1	185	1.2	P-5
HSKA63HYDRO20X90T	20	42	50	38	90	51	10	48	64	M16x1	330	1.3	P-5
HSKA63HYDRO25X120T	25	57	-	53	120	57	10	94	-	M16x1	400	2.16	P-6
HSKA63HYDRO32X125T	32	62	-	58	125	61	10	99	-	M16x1	650	2.7	P-6
HSKA100HYDRO10X90T	10	30	50	26	90	41	10	42	61	M8x1	45	2.5	P-5
HSKA100HYDRO12X95T	12	32	50	28	95	46	10	47	66	M10x1	90	2.6	P-5
HSKA100HYDRO16X100T	16	38	50	34	100	49	10	53	71	M12x1	185	2.7	P-5
HSKA100HYDRO20X105T	20	42	50	38	105	51	10	59	76	M16x1	330	2.8	P-5
HSKA100HYDRO25X110T	25	57	63	53	110	57	10	62	81	M16x1	400	3.7	P-6
HSKA100HYDRO32X110T	32	64	75	60	110	61	10	62	81	M16x1	650	3.8	P-6

* Wrench is not included. Please order separately.
Please use cooling tube (not included).
Tool shank tolerance: h6
Balanced to G2.5, max n: 25,000 min⁻¹

COOLING TUBE-HSK

Cooling tube for HSK shank

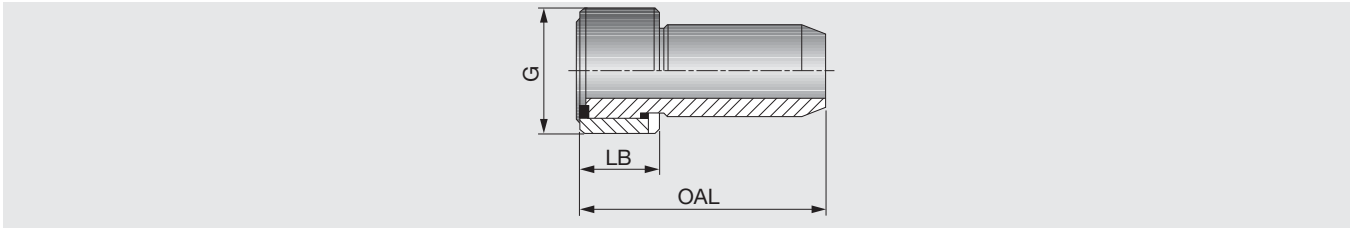

Designation	HSK size	OAL	LB	G
COOLINGTUBEHSKA63	63	36	11.5	M18X1
COOLINGTUBEHSKA100	100	43.6	15.5	M24X1.5

WRENCH

Wrench for HSK cooling tube

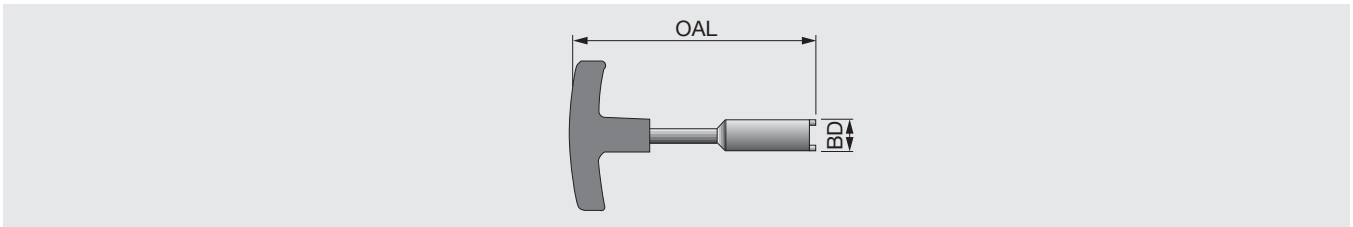

Designation	HSK size	BD	OAL
WRENCH COOL TUBE HSK63	63	17	122
WRENCH COOL TUBE HSK100	100	22	141

New

SK-HYDRO-T

TungHydro hydraulic endmill chuck holders with SK shank

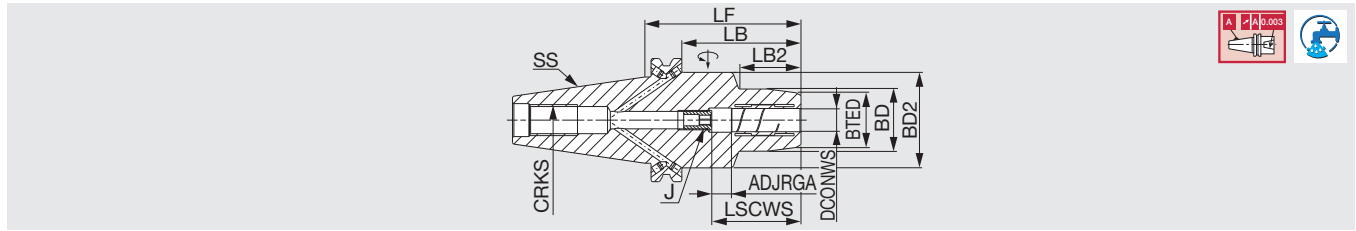

Designation	SS	DCONWS	BD	BD2	BTED	LF	LSCWS	ADJRGA	LB2	LB	J	Min. Torque (N-m)	WT(kg)	CRKS	Wrench*
SK40HYDRO6X80.5T	40	6	26	49.25	22	80.5	37	10	29.5	61.4	M5	16	1.4	M16	P-5
SK40HYDRO8X80.5T	40	8	28	49.25	24	80.5	37	10	30	61.4	M6	23	1.4	M16	P-5
SK40HYDRO10X80.5T	40	10	30	49.25	26	80.5	41	10	31	61.4	M8x1	45	1.4	M16	P-5
SK40HYDRO12X80.5T	40	12	32	49.25	28	80.5	46	10	31.5	61.4	M10x1	90	1.4	M16	P-5
SK40HYDRO16X80.5T	40	16	38	49.25	34	80.5	49	10	33	61.4	M12x1	185	1.4	M16	P-5
SK40HYDRO20X80.5T	40	20	42	49.25	38	80.5	51	10	34	61.4	M16x1	330	1.4	M16	P-5
SK40HYDRO25X80.5T	40	25	55	65.95	53	80.5	57	10	22	61.4	M16x1	400	1.8	M16	P-6
SK40HYDRO32X80.5T	40	32	63	72.95	60	80.5	61	10	25.5	61.4	M16x1	650	2	M16	P-6
SK50HYDRO12X80.5T	50	12	32	49.25	28	80.5	46	10	31.5	61.45	M10x1	90	3.2	M24	P-5
SK50HYDRO16X80.5T	50	16	38	49.25	34	80.5	49	10	33	61.45	M12x1	185	3.2	M24	P-5
SK50HYDRO20X80.5T	50	20	42	49.25	38	80.5	51	10	34	61.45	M16x1	330	3.3	M24	P-5
SK50HYDRO32X103.2T	50	32	64	70.25	60	103.2	61	10	62.5	81.15	M16x1	650	4.4	M24	P-6

* Wrench is not included. Please order separately.
 Tool shank tolerance: h6
 Balanced to G2.5, max n: 25,000 min⁻¹

New

CAT-HYDRO-T

TungHydro hydraulic endmill chuck holders with CAT shank

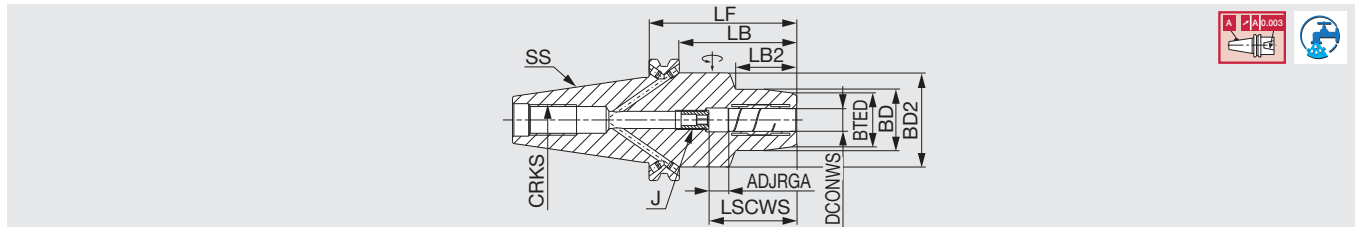

Designation	SS	DCONWS	BD	BD2	BTED	LF	LSCWS	ADJRGA	LB2	LB	J	Min. Torque (N-m)	WT(kg)	CRKS	Wrench*
CAT40HYDRO6X63.5T	40	6	26	44.45	19.8	63.5	37	10	25	44.45	M5	16	1.1	5/8-11	P-5
CAT40HYDRO8X63.5T	40	8	28	49	23.5	63.5	37	10	26	44.45	M5	23	1.1	5/8-11	P-5
CAT40HYDRO10X63.5T	40	10	30	49	24	63.5	41	10	28	44.45	M5	45	1.1	5/8-11	P-5
CAT40HYDRO12X63.5T	40	12	32	49	27.1	63.5	46	10	27	44.45	M10x1	90	1.1	5/8-11	P-5
CAT40HYDRO16X63.5T	40	16	38	49	33.1	63.5	49	10	28	44.45	M10x1	185	1.2	5/8-11	P-5
CAT40HYDRO20X63.5T	40	20	42	49	37.6	63.5	51	10	26	44.45	M10x1	330	1.2	5/8-11	P-5
CAT40HYDRO1/4X2.500T ⁽¹⁾	40	1/4"	26	44.45	19.8	63.5	37	10	25	44.45	M5	17	1.1	5/8-11	P-5
CAT40HYDRO3/8X2.500T ⁽¹⁾	40	3/8"	30	49	24	63.5	41	10	28	44.45	M5	45	1.1	5/8-11	P-5
CAT40HYDRO1/2X2.500T ⁽¹⁾	40	1/2"	32	49	27	63.5	46	10	24.5	44.45	M10x1	95	1.1	5/8-11	P-5
CAT40HYDRO5/8X2.500T ⁽¹⁾	40	5/8"	38	49	33.1	63.5	49	10	28	44.45	M10x1	185	1.2	5/8-11	P-5
CAT40HYDRO3/4X2.500T ⁽¹⁾	40	3/4"	44.5	49	38	63.5	51	10	23.17	44.45	M10x1	310	1.2	5/8-11	P-5
CAT50HYDRO12X81T	50	12	32	49	25.5	81	46	10	40	61.95	M10x1	90	3.1	1-8	P-5
CAT50HYDRO20X81T	50	20	42	51	35.5	81	51	10	46	61.95	M10x1	330	3.2	1-8	P-5
CAT50HYDRO25X81T	50	25	48	68	41.5	81	57	10	35.4	61.95	M10x1	400	3.5	1-8	P-6
CAT50HYDRO32X81T	50	32	62	75	55.8	81	61	10	40	61.95	M10x1	650	3.8	1-8	P-6
CAT50HYDRO1/2X3.189T ⁽¹⁾	50	1/2"	32	44.45	27.7	81	46	10	31.5	61.95	M10x1	95	3.1	1-8	P-5
CAT50HYDRO3/4X3.189T ⁽¹⁾	50	5/8"	44.5	49	38.9	81	51	10	43.17	61.95	M10x1	310	3.2	1-8	P-5
CAT50HYDRO1X3.189T ⁽¹⁾	50	1"	48	48	43.3	81	57	10	38.5	61.95	M10x1	400	3.4	1-8	P-6
CAT50HYDRO1-1/4X3.189T ⁽¹⁾	50	1 1/4"	62	75	55.8	81	61	10	40	61.95	M10x1	650	3.8	1-8	P-6

(1) inch
 * Wrench is not included. Please order separately.
 Tool shank tolerance: h6
 Balanced to G2.5, max n: 25,000 min⁻¹

Tungaloy Corporation (Head office)

11-1 Yoshima-Kogyodanchi
Iwaki-city, Fukushima 970-1144 Japan
Phone: +81-246-36-8501
Fax: +81-246-36-8542
www.tungaloy.co.jp

Tungaloy-NTK America Inc.

3726 N Ventura Drive
Arlington Heights, IL 60004, U.S.A.
Phone: +1-888-554-8394
Fax: +1-888-554-8392
www.tungaloy.com/us

Tungaloy Canada

432 Elgin St. Unit 3
Brantford, Ontario N3S 7P7, Canada
Phone: +1-519-758-5779
Fax: +1-519-758-5791
www.tungaloy.com/ca

Tungaloy-NTK De Mexico S.A.

C. Los Arellano 113,
Parque Industrial Siglo XXI
Aguascalientes, AGS, Mexico 20290
Phone: +52-449-929-5410
Fax: +52-449-929-5411
www.tungaloy.com/mx

Tungaloy-NTK do Brasil Ltda.

Avd. Independencia N4158 Residencial Flora
13280-000 Vinhedo, São Paulo, Brasil
Phone: +55-19-38262757
Fax: +55-19-38262757
www.tungaloy.com/br

Tungaloy-NTK Germany GmbH.

Katzbergstr. 3a
D-40764 Langenfeld, Germany
Phone: +49-2173-90420-0
Fax: +49-2173-90420-19
www.tungaloy.com/de

Tungaloy France s.a.s

Les Fjords
19 avenue de Norvège
91140 Villebon Sur Yvette, France
Phone: +33-1-6486-4300
Fax: +33-1-6907-7817
www.tungaloy.com/fr

Tungaloy Italia S.r.l.

Viale Sarca 336/Edificio 13
20126 Milano, Italy
Phone: +39-02-252012-1
Fax: +39-02-252012-65
www.tungaloy.com/it

Tungaloy Czech s.r.o.

Turanka 1583/115g,
627 00 Brno, Czech Republic
Phone: +420-532 123 391
www.tungaloy.com/cz

Tungaloy Ibérica S.L.

C/Miquel Servet, 43B, Nau 7
Pol. Ind. Bufalvent
ES-08243 Manresa (BCN), Spain
Phone: +34 93 113 1360
www.tungaloy.com/es

Tungaloy Scandinavia AB

Bultgatan 38
442 40 Kungälv, Sweden
Phone: +46-462119200
Fax: +46-462119207
www.tungaloy.com/se

Tungaloy Rus, LLC

Andropova avenue, h.18/7,
11 floor, office 3, 115432,
Moscow, Russia
Phone: +7-499-683-01-80
Fax: +7-499-683-01-81
www.tungaloy.com/ru

Tungaloy Polska Sp. z o.o.

Ul. Irysowa 1, 55-040 Bielany
Wroclawskie, Poland
Phone: +48 607 907 237
www.tungaloy.com/pl

Tungaloy-NTK UK Ltd.

Suite 3, Pioneer House, Mill Street,
Cannock, WS11 0EF, UK
Phone: +44 121 4000 231
Fax: +44 121 270 9694
www.tungaloy.com/uk

Tungaloy Hungary Kft

Erzsébet királyné útja 125
H-1142 Budapest, Hungary
Phone: +36 1 781-6846
Fax: +36 1 781-6866
www.tungaloy.com/hu

Tungaloy Turkey

Serifali Mah.bayraktar Bulvari Kule Sk. No:26
34775 Umraniye / Istanbul / Turkey
Phone: +90 216 540 04 67
Fax: +90 216 540 04 87
www.tungaloy.com/tr

Tungaloy Benelux b.v.

Tjalk 70
NL-2411 NZ Bodegraven, Netherlands
Phone: +31 172 630 420
Fax: +31 172 630 429
www.tungaloy.com/nl

Tungaloy Croatia

Ulica bana Josipa Jelačića 87,
10430, Samobor, Croatia
Phone: +385 1 3326 604
Fax: +385 1 3327 683
www.tungaloy.com/hr

Tungaloy Cutting Tool (Shanghai) Co. Ltd.

Rm No 401 No.88 Zhabei
Jiangchang No.3 Rd
Shanghai 200436, China
Phone: +86-21-3632-1880
Fax: +86-21-3621-1918
www.tungaloy.com/cn

Tungaloy Cutting Tools Taiwan Co. Ltd.

9F, No.293, Zhongyang Rd,
Xinzhuang Dist, New Taipei City,
24251 Taiwan
Phone: +886-2-8521-9986
Fax: +886-2-8521-8935
www.tungaloy.com/tw

Tungaloy-NTK Cutting Tool (Thailand) Co.,Ltd.

Interlink tower 4th Fl.
1858/5-7 Bangna-Trad Road
km.5 Bangna, Bangna, Bangkok 10260
Thailand
Phone: +66-2-751-5711
Fax: +66-2-751-5715
www.tungaloy.com/th

Tungaloy Singapore (Pte.), Ltd.

62 Ubi Road 1, #08-09 Oxley BizHub 2
Singapore 408734
Phone: +65-6391-1833
Fax: +65-6299-4557
www.tungaloy.com/sg

Tungaloy-NTK Vietnam LLC

3rd Floor, Licogi 13 Tower, 164 Khuat Duy
Tien, Nhan Chinh, Thanh Xuan District,
Hanoi, Vietnam
Phone: +84 24 63282086
www.tungaloy.com/vn

Tungaloy India Pvt. Ltd.

One International Center,
Unit # 902-A, 9th Floor,
Tower 1, Senapati Bapat Marg,
Elphinstone Road (West),
Mumbai 400013, India
Phone: +91-22-6124-8803
Fax: +91-22-6124-8899
www.tungaloy.com/in

Tungaloy Korea Co., Ltd

#1312, Byucksan Digital Valley 5-cha
Beotkkot-ro 244, Geumcheon-gu
153-788 Seoul, Korea
Phone: +82-2-2621-6161
Fax: +82-2-6393-8952
www.tungaloy.com/kr

Tungaloy Malaysia Sdn Bhd

50 K-2, Kelana Mall, Jalan SS6/14
Kelana Jaya, 47301
Petaling Jaya, Selangor Darul Ehsan
Malaysia
Phone: +603-7805-3222
Fax: +603-7804-8563
www.tungaloy.com/my

Tungaloy Australia Pty Ltd

Unit 68 1470 Ferntree Gully Road
Knoxfield 3180 Victoria, Australia
Phone: +61-3-9755-8147
Fax: +61-3-9755-6070
www.tungaloy.com/au

PT. Tungaloy Indonesia

Ruko Blok AA.10 No3&5, Grand Wisata,
Lambangjaya, Tambun Selatan, Bekasi,
17510 Indonesia
Phone: +62-21-8261-5808
Fax: +62-21-8261-5809
www.tungaloy.com/id



tungaloy.com

follow us at:

facebook.com/tungaloyjapan

twitter.com/tungaloyjapan

www.youtube.com/tungaloycorporation

Distributed by:



Tungaloy APP & SNS

FIND US ON THE CLOUD!
machingcloud.com



AS9100 Certified
78006
2015.11.04
ISO 14001 Certified
EC97J1123
1997.11.26