



For more information

Face milling cutter

**DOOCTO**

Tungaloy Report No. 385-US

# Expanded PVD grade AH8015 and cost-effective cutter bodies





TANO7R080M25-45

PINDLE SYSTEM No. WKA06515A

Tungaloy

TANO7R080M25-45  
MAX. RPM=6000  
(11)317550



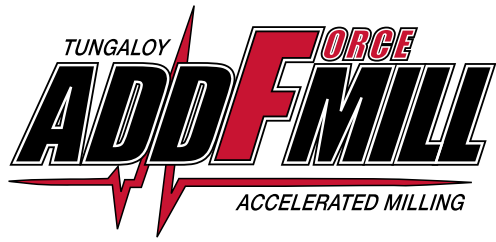

## DOOCTO

---



Economical face milling cutter with good depth of cut capability

Enhanced geometries and grades for machining a wide range of materials, **especially for milling cast iron**

**Rich grade lineup for every kind of material**

**New**

## AH8015

**K S H P**

- PVD coated grades with hard coating layer and carbide substrate
- Strong resistance to wear, heat, and built-up edge, ideal for machining hardened steel, heat resistant super alloy or cast iron

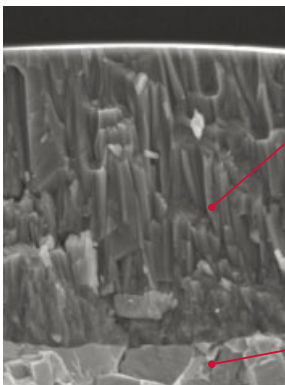

**PVD grade featuring high aluminum-content multilayered coating**

- A combination of over 20% harder coating surface and multilayered coating structure helps prevent micro-cracks from progressing into catastrophic failure.
- Enhanced adhesion of coating and substrate eliminates delamination.

**New dedicated substrate**

- Dedicated carbide substrate with excellent wear resistance

## AH3225 **P M K H**

- Nano multi-layer coating technology with three major properties for optimal cutting edge integrity
- Increased resistance to wear, fracture, oxidation, built-up edge, and delamination

## AH3135 **M P S H**

- PVD grade for high fracture resistance
- Most suitable for steel and stainless steel in general cutting parameters

## AH120 **K P**

- PVD grade with a well-balanced wear and fracture resistance
- Ideal for general machining of steel and stainless steel

## T1215 **K**

- CVD grade with outstanding wear and chipping resistance
- Best for cast iron at high-speed machining

## T3225 **P M**

- CVD grade with high chipping and fracture resistance

## AH130 **M S**

- Demonstrates high wear and chipping resistance in the machining of Titanium alloy or heat-resistant alloys
- Remarkable reliability in wet machining

## APPLICATION AREAS

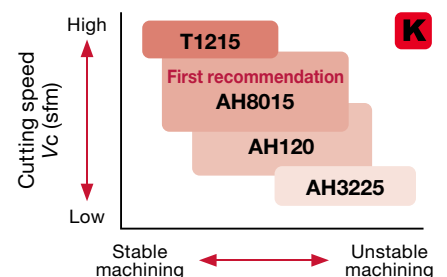
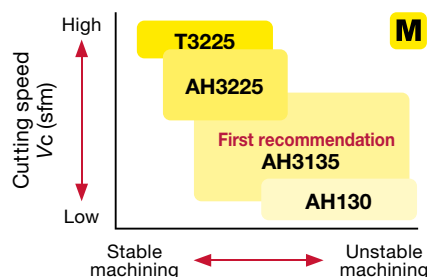
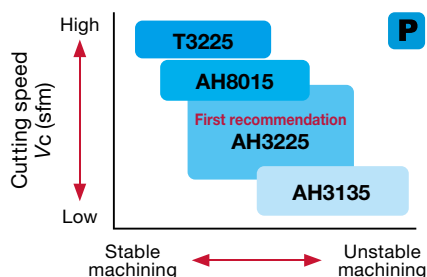

## Now offering new cutter bodies without coolant hole

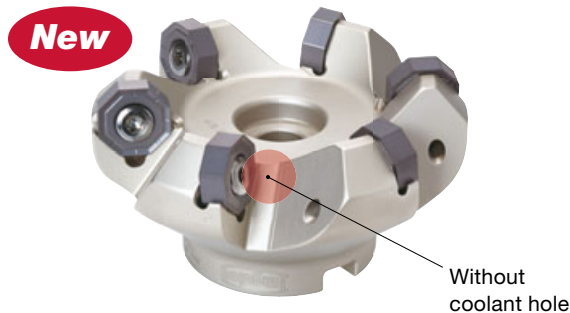

- New cutter bodies are available in diameters: 80, 100, and 125 mm without coolant hole
- More cost-effective than cutter bodies with coolant holes
- Ideal for dry machining applications
- Irregular pitched cutting teeth, like the existing cutter lineup, provide excellent chatter resistance

## Enhanced cutter body lineup

Including cutter diameters of  $> \varnothing 8.000''$ ,  $\varnothing 315$  mm or extra close pitched design for effective cast iron milling



standard or close pitch (screw clamping)

### For general purpose

- Optimized orientation of coolant outlet which is located in a large chip gullet facilitates smooth chip evacuation.
- Large clamping screw enhances insert security.
- Cutter diameters:  $\varnothing 2.500'' - \varnothing 8.000''$ ,  $\varnothing 63$  mm -  $\varnothing 315$  mm



Extra close pitch (wedge clamping)

### For efficient cast iron milling

- Offers twice as much insert density as a screw clamping style cutter with easy indexability.
- Cutter diameters:  $\varnothing 2.500'' - \varnothing 8.000''$ ,  $\varnothing 63$  mm -  $\varnothing 200$  mm



OWMT inserts do not fit the cutter body with wedge clamping method.

## Inserts are available in single-sided or double-sided geometry

Covering large cutting depths and high feed applications

Double-sided, octagonal inserts (economy)



ONMU / ONHU

Double-sided, square inserts (large cutting depths)



SNMU / SNHU

Single-sided, octagonal insert (with low cutting load, high feed rates)



OWMT

MJ chipbreaker

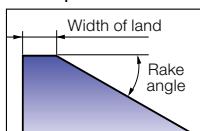

ML chipbreaker

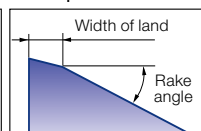

MJ chipbreaker

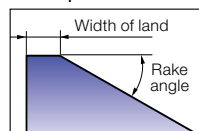

ML chipbreaker

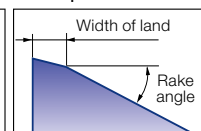

ML chipbreaker

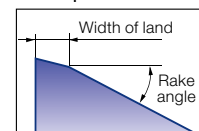

HJ chipbreaker

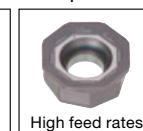

## ONMU and ONHU (double-sided, octagonal) inserts

- Economical 16-edged insert
- 40% larger insert size (IC = 0.681") to enhance insert strength

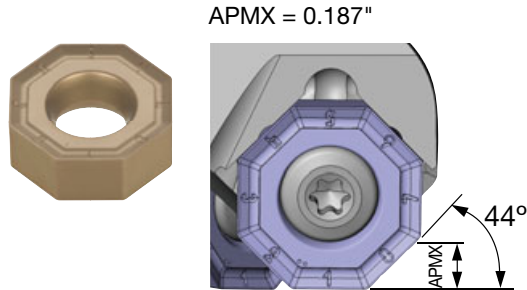

### Tool life

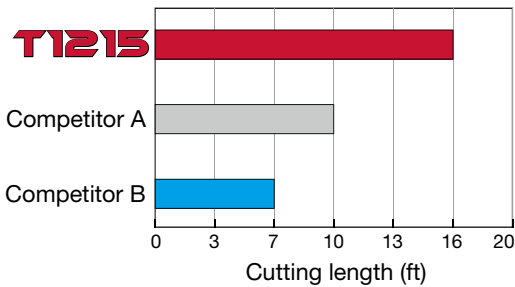

**K** Cutter : TAN07R250U0075A06 (ø2.500", CICT = 1)  
 Insert : ONMU0705ANPN-MJ T1215  
 Workpiece material : 80-55-06 (160HB)  
 Cutting speed :  $V_c = 820$  sfm  
 Feed per tooth :  $f_z = 0.012$  ipt  
 Depth of cut :  $a_p = 0.157$ "  
 Width of cut :  $a_e = 2.362$ "  
 Coolant : Dry

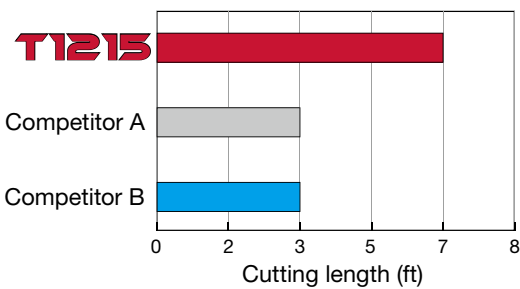

**K** Cutter : TAN07R300U0100A08 (ø3.000", CICT = 1)  
 Insert : ONMU0705ANPN-MJ T1215  
 Workpiece material : 80-55-06 (160HB)  
 Cutting speed :  $V_c = 492$  sfm  
 Feed per tooth :  $f_z = 0.012$  ipt  
 Depth of cut :  $a_p = 0.157$ "  
 Width of cut :  $a_e = 2.362$ "  
 Coolant : Wet

### Surface roughness (with wiper insert)

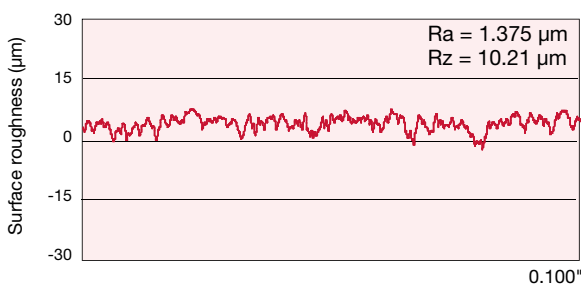

**K** Cutter : TAN07R300U0100A08 (ø3.000", CICT = 8)  
 Insert : ONHU0705ANTN-ML AH120 (7/8 pockets)  
           : ONHU0705ANPR-W AH120 (1/8 pocket)  
 Workpiece material : 250 (180HB)  
 Cutting speed :  $V_c = 820$  sfm  
 Feed per tooth :  $f_z = 0.008$  ipt  
 Depth of cut :  $a_p = 0.120$ "  
 Width of cut :  $a_e = 2.400$ "  
 Coolant : Dry

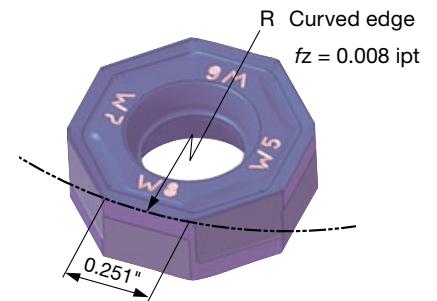

## ■ SNMU and SNHU (double-sided, square) inserts

- Allows large depths of cut up to 0.295" - ideal for removing scales
- 40% larger insert size (IC = 0.681") to enhance insert strength
- Large inclination angle on the cutting edge facilitates smooth chip evacuation

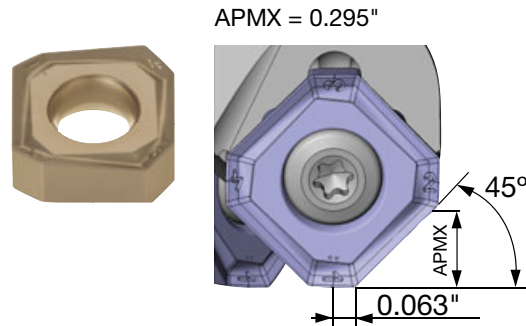

### ■ Cutting performance

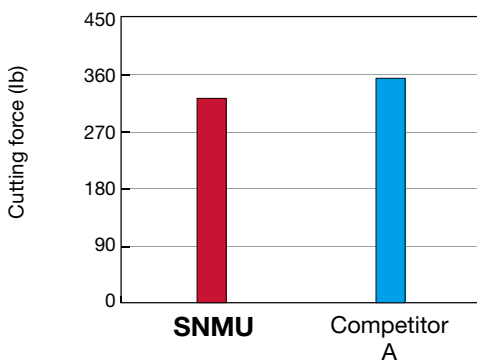

<b>P</b>	Cutter	: TAN07R400U0150A07 (ø4.000", CICT = 1)
	Insert	: SNMU1706ANTR-ML AH3135
	Workpiece material	: 1055 (200HB)
	Cutting speed	: $V_c = 492$ sfm
	Feed per tooth	: $f_z = 0.008$ ipt
	Depth of cut	: $a_p = 0.118$ "
	Width of cut	: $a_e = 2.756$ "
Coolant	: Dry	

### ■ Tool life

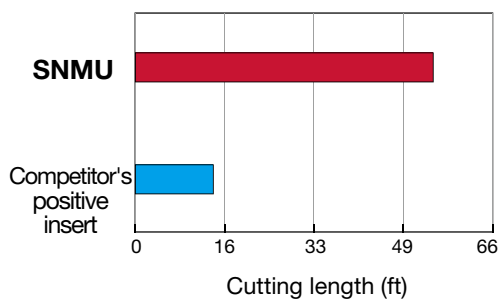

<b>P</b>	Cutter	: TAN07R500U0150A08 (ø5.000", CICT = 1)
	Insert	: SNMU1706ANPR-MJ AH3135
	Workpiece material	: 1055 (200HB)
	Cutting speed	: $V_c = 515$ sfm
	Feed per tooth	: $f_z = 0.006$ ipt
	Depth of cut	: $a_p = 0.079$ "
	Width of cut	: $a_e = 4.724$ "
Coolant	: Dry	

## OWMT (single-sided, octagonal) inserts

- Offers ML style chipbreaker for up to 0.138" depth of cut and HJ style chipbreaker for high feed milling
- Free cutting, positive geometry
- Economical insert with 8 cutting edges

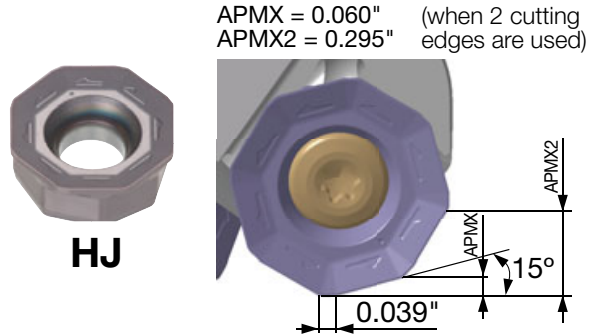
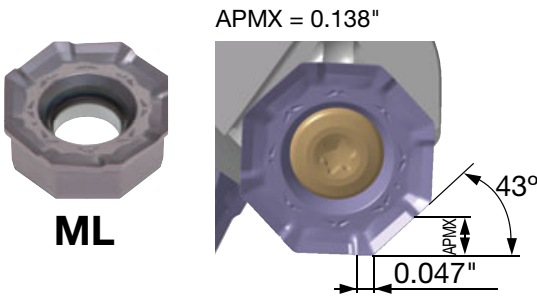

### Cutting performance

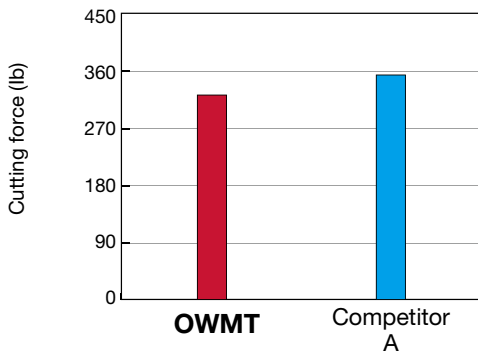

**P**

Cutter	: TAN07R400U0150A07 (ø4.000", CICT = 1)
Insert	: OWMT0807AAER-ML AH3135
Workpiece material	: 1055 (200HB)
Cutting speed	: Vc = 492 sfm
Feed per tooth	: fz = 0.008 ipt
Depth of cut	: ap = 0.118"
Width of cut	: ae = 2.756"
Coolant	: Dry

### Tool life

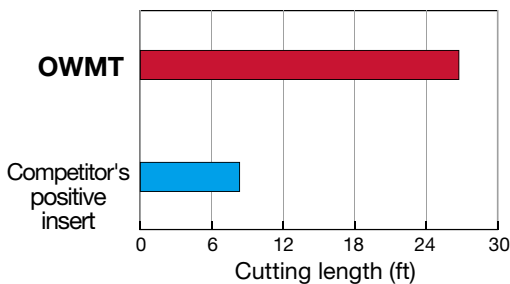

**M**

Cutter	: TAN07R400U0150A07 (ø4.000", CICT = 1)
Insert	: OWMT0807AAER-ML AH3135
Workpiece material	: 304 (200HB)
Cutting speed	: Vc = 492 sfm
Feed per tooth	: fz = 0.008 ipt
Depth of cut	: ap = 0.098"
Width of cut	: ae = 2.756"
Coolant	: Dry

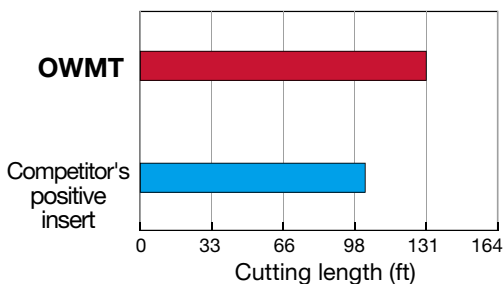

**P**

Cutter	: TAN07R400U0150A07 (ø4.000", CICT = 1)
Insert	: OWMT0807ZNER-HJ AH3135
Workpiece material	: 1055 (200HB)
Cutting speed	: Vc = 656 sfm
Feed per tooth	: fz = 0.039 ipt
Depth of cut	: ap = 0.039"
Width of cut	: ae = 2.362"
Coolant	: Dry

# TAN07

Face mill, with screw clamp system

GAMP=-6°, GAMF=+15.5°

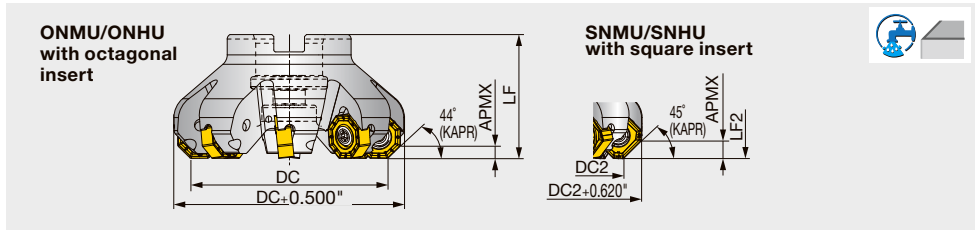

Inch	DC	DC2	CICT	DCSFMS	LF	LF2	DCONMS	CBDP	KWW	b	WT (lb)	Air hole	Insert	Arbor type
TAN07R250U0075A05	2.500	2.394	5	1.750	1.750	1.805	0.750	0.750	0.313	0.188	1.000	With	SN*U/ON*U...	A
TAN07R250U0075A06	2.500	2.394	6	1.750	1.750	1.805	0.750	0.750	0.313	0.188	1.000	With	SN*U/ON*U...	A
TAN07R300U0100A06	3.000	2.894	6	2.000	2.000	2.055	1.000	0.750	0.375	0.219	2.000	With	SN*U/ON*U...	A
TAN07R300U0100A08	3.000	2.894	8	2.000	2.000	2.055	1.000	0.750	0.375	0.219	2.000	With	SN*U/ON*U...	A
TAN07R400U0150A07	4.000	3.894	7	2.400	2.000	2.055	1.500	1.000	0.625	0.375	3.000	With	SN*U/ON*U...	B
TAN07R400U0150A10	4.000	3.894	10	2.400	2.000	2.055	1.500	1.000	0.625	0.375	3.000	With	SN*U/ON*U...	B
TAN07R500U0150A08	5.000	4.894	8	2.400	2.500	2.555	1.500	1.000	0.625	0.375	5.000	With	SN*U/ON*U...	B
TAN07R500U0150A12	5.000	4.894	12	2.400	2.500	2.555	1.500	1.000	0.625	0.375	5.000	With	SN*U/ON*U...	B
TAN07R600U0200A10	6.000	5.894	10	4.000	2.500	2.555	2.000	1.000	0.750	0.438	7.000	Without	SN*U/ON*U...	B
TAN07R600U0200A15	6.000	5.894	15	4.000	2.500	2.555	2.000	1.000	0.750	0.438	7.000	Without	SN*U/ON*U...	B
TAN07R800U0250A12	8.000	7.894	12	5.300	2.500	2.555	2.500	1.400	1.000	0.531	13.000	Without	SN*U/ON*U...	C
TAN07R800U0250A18	8.000	7.894	18	5.300	2.500	2.555	2.500	1.400	1.000	0.531	13.000	Without	SN*U/ON*U...	C

## Dimension when using positive type inserts (OWMT)

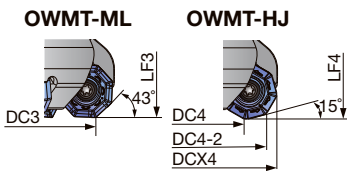

Inch	OWMT-ML		OWMT-HJ			
	DC3	LF3	DC4	DC4-2	DCX4	LF4
TAN07R250U0075A...	2.520	1.789	3.000	2.665	3.028	1.805
TAN07R300U0100A...	3.020	2.039	3.500	3.165	3.528	2.055
TAN07R400U0150A...	4.020	2.039	4.500	4.165	4.528	2.055
TAN07R500U0150A...	5.020	2.539	5.500	5.165	5.528	2.555
TAN07R600U0200A...	6.020	2.539	6.500	6.165	6.528	2.555
TAN07R800U0250A...	8.020	2.539	8.500	8.165	8.528	2.555

OWMT08 inserts can be only used with screw on type cutters.

## Arbor type

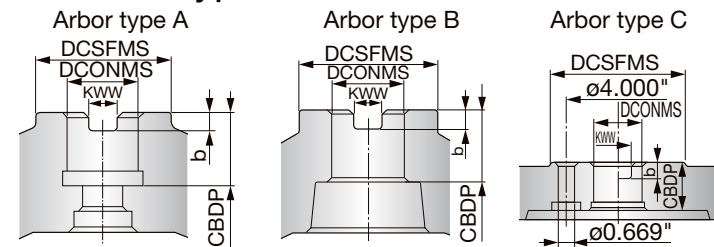

## SPARE PARTS



Designation	Clamping screw	Grip	Lubricant (Optional)	Torx bit	Shell locking bolt (Optional)
TAN07R250...	SRM5X0.8IP20X+ACROLYTE	H-TB	(M-1000)	BLD IP20/S7	(C0.375X1.125H)
TAN07R300...	SRM5X0.8IP20X+ACROLYTE	H-TB	(M-1000)	BLD IP20/S7	(C0.500X1.375H)
TAN07R400, 500...	SRM5X0.8IP20X+ACROLYTE	H-TB	(M-1000)	BLD IP20/S7	(TMBA-0.750H)
TAN07R600, 800...	SRM5X0.8IP20X+ACROLYTE	H-TB	(M-1000)	BLD IP20/S7	-

Recommended clamping torque: 5.53 lbs-ft

# TAN07

Face mill, with screw clamp system

GAMP=-6°, GAMF=+15.5°



**ONMU/ONHU**  
with octagonal insert

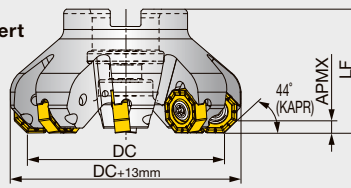

**SNMU/SNHU**  
with square insert

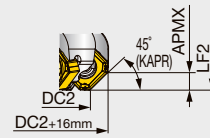

Metric	DC	DC2	CICT	DCSFMS	LF	LF2	DCONMS	CBDP	KWW	b	WT(kg)	Air hole	Insert	Arbor type
TAN07R063M22.0E05	63	60.3	5	41	40	41.4	22	20	10.4	6.3	0.5	with	SN*U/ON*U...	A
TAN07R063M22.0E06	63	60.3	6	41	40	41.4	22	20	10.4	6.3	0.5	with	SN*U/ON*U...	A
TAN07R080M25.4-06	80	77.3	6	50	50	51.4	25.4	26	9.5	6	1	with	SN*U/ON*U...	A
TAN07R080M25.4-08	80	77.3	8	50	50	51.4	25.4	26	9.5	6	1	with	SN*U/ON*U...	A
TAN07R080M27.0E06	80	77.3	6	50	50	51.4	27	22	12.4	7	1	with	SN*U/ON*U...	A
TAN07R080M27.0E08	80	77.3	8	50	50	51.4	27	22	12.4	7	1	with	SN*U/ON*U...	A
TAN07R100M31.7-07	100	97.3	7	60	50	51.4	31.75	32	12.7	8	1.5	with	SN*U/ON*U...	B
TAN07R100M31.7-10	100	97.3	10	60	50	51.4	31.75	32	12.7	8	1.5	with	SN*U/ON*U...	B
TAN07R100M32.0E07	100	97.3	7	60	50	51.4	32	28.5	14.4	8	1.5	with	SN*U/ON*U...	B
TAN07R100M32.0E10	100	97.3	10	60	50	51.4	32	28.5	14.4	8	1.5	with	SN*U/ON*U...	B
TAN07R125M38.1-08	125	122.3	8	80	63	64.4	38.1	38	15.9	10	2.5	with	SN*U/ON*U...	B
TAN07R125M38.1-12	125	122.3	12	80	63	64.4	38.1	38	15.9	10	2.5	with	SN*U/ON*U...	B
TAN07R125M40.0E08	125	122.3	8	71	63	64.4	40	29	16.4	9	2.5	with	SN*U/ON*U...	B
TAN07R125M40.0E12	125	122.3	12	71	63	64.4	40	29	16.4	9	2.5	with	SN*U/ON*U...	B
TAN07R160M40.0E10	160	157.3	10	100	63	64.4	40	29	16.4	9	4	without	SN*U/ON*U...	D
TAN07R160M40.0E15	160	157.3	15	100	63	64.4	40	29	16.4	9	4	without	SN*U/ON*U...	D
TAN07R160M50.8-10	160	157.3	10	100	63	64.4	50.8	38	19	11	4	without	SN*U/ON*U...	B
TAN07R160M50.8-15	160	157.3	15	100	63	64.4	50.8	38	19	11	4	without	SN*U/ON*U...	B
TAN07R200M47.6-12	200	197.3	12	130	63	64.4	47.625	38	25.4	14	6.6	without	SN*U/ON*U...	C
TAN07R200M47.6-18	200	197.3	18	130	63	64.4	47.625	38	25.4	14	6.7	without	SN*U/ON*U...	C
TAN07R200M60.0E12	200	197.3	12	135	63	64.4	60	38	25.7	14	6.5	without	SN*U/ON*U...	C
TAN07R200M60.0E18	200	197.3	18	135	63	64.4	60	38	25.7	14	6.5	without	SN*U/ON*U...	C
TAN07R250M47.6-15	250	247.3	15	130	63	64.4	47.625	38	25.4	14	9.3	without	SN*U/ON*U...	C
TAN07R250M47.6-21	250	247.3	21	130	63	64.4	47.625	38	25.4	14	9.4	without	SN*U/ON*U...	C
TAN07R250M60.0E15	250	247.3	15	130	63	64.4	60	38	25.7	14	9	without	SN*U/ON*U...	C
TAN07R250M60.0E21	250	247.3	21	130	63	64.4	60	38	25.7	14	9	without	SN*U/ON*U...	C
TAN07R315M47.6-18	315	312.3	18	220	63	64.4	47.625	38	25.4	14	17.9	without	SN*U/ON*U...	C
TAN07R315M47.6-24	315	312.3	24	220	63	64.4	47.625	38	25.4	14	18	without	SN*U/ON*U...	C
TAN07R315M60.0E18	315	312.3	18	220	80	81.4	60	38	25.7	14	18	without	SN*U/ON*U...	E
TAN07R315M60.0E24	315	312.3	24	220	80	81.4	60	38	25.7	14	18	without	SN*U/ON*U...	E

Dimension when using positive type inserts (OWMT)

Metric	OWMT-ML		OWMT-HJ			
	DC3	LF3	DC4	DC4-2	DCX4	LF4
TAN07R063M...	63.5	41	55.7	67.2	76.4	41.4
TAN07R080M...	80.5	51	72.7	84.2	93.4	51.4
TAN07R100M...	100.5	51	92.7	104.2	113.4	51.4
TAN07R125M...	125.5	64	117.7	129.2	138.4	64.4
TAN07R160M...	160.5	64	152.7	164.2	173.4	64.4
TAN07R200M...	200.5	64	192.7	204.2	213.4	64.4
TAN07R250M...	250.5	64	242.7	254.2	263.4	64.4
TAN07R315M...	315.5	64	307.7	319.2	328.4	64.4

Note: OWMT08 inserts can be only used with screw on type cutters.

## Arbor type

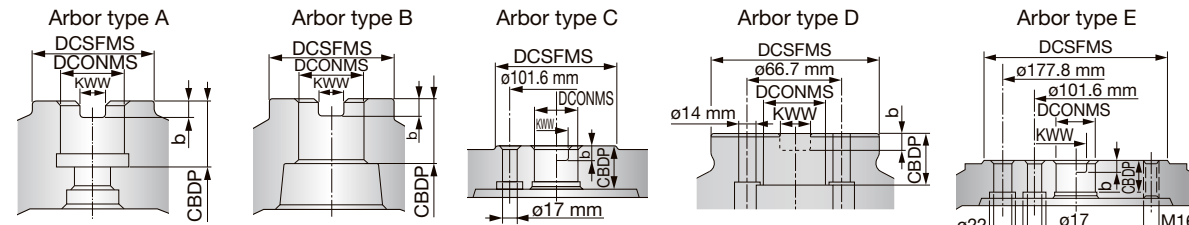

## SPARE PARTS

Designation	Clamping screw	Grip	Lubricant (Optional)	Shell locking bolt 1	Shell locking bolt 2	Torx bit
TAN07R063M22.0...	SRM5X0.8IP20X+ACROLYTE	H-TB	(M-1000)	-	CM10X30H	BLD IP20/S7
TAN07R080M25.4...	SRM5X0.8IP20X+ACROLYTE	H-TB	(M-1000)	-	CM12X30H	BLD IP20/S7
TAN07R100M31.7...	SRM5X0.8IP20X+ACROLYTE	H-TB	(M-1000)	TMBA-M16H	-	BLD IP20/S7
TAN07R125M38.1...	SRM5X0.8IP20X+ACROLYTE	H-TB	(M-1000)	TMBA-M20H	-	BLD IP20/S7
TAN07R160 - 315...	SRM5X0.8IP20X+ACROLYTE	H-TB	(M-1000)	-	-	BLD IP20/M7

Recommended clamping torque : SRM5X0.8IP20X+ACROLYTE = 7.5 N·m

**New**

**TAN07\*\*N**

Face mill, with screw clamp system (without internal coolant)

GAMP=-6°,GAMF=+15.5°

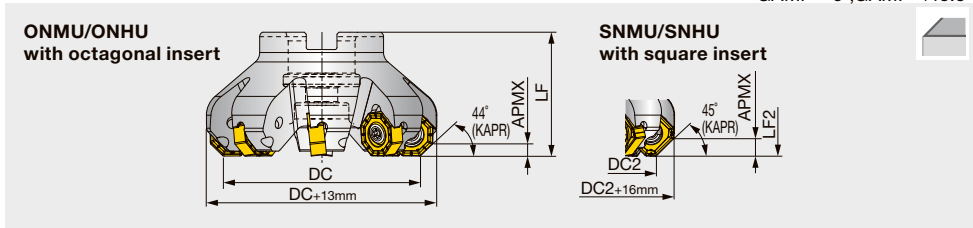

Metric	DC	DC2	CICT	DCSFMS	LF	LF2	DCONMS	CBDP	KWW	b	WT(kg)	Air hole	Insert	Arbor type
TAN07R080M25.4-06N	80	77.3	6	50	50	51.4	25.4	26	9.5	6	1	without	SN*U/ON*U...	A
TAN07R080M25.4-08N	80	77.3	8	50	50	51.4	25.4	26	9.5	6	1	without	SN*U/ON*U...	A
TAN07R080M27.0E06N	80	77.3	6	50	50	51.4	27	22	12.4	7	1	without	SN*U/ON*U...	A
TAN07R080M27.0E08N	80	77.3	8	50	50	51.4	27	22	12.4	7	1	without	SN*U/ON*U...	A
TAN07R100M31.7-07N	100	97.3	7	60	50	51.4	31.75	32	12.7	8	1.5	without	SN*U/ON*U...	B
TAN07R100M31.7-10N	100	97.3	10	60	50	51.4	31.75	32	12.7	8	1.5	without	SN*U/ON*U...	B
TAN07R100M32.0E07N	100	97.3	7	60	50	51.4	32	28.5	14.4	8	1.5	without	SN*U/ON*U...	B
TAN07R100M32.0E10N	100	97.3	10	60	50	51.4	32	28.5	14.4	8	1.5	without	SN*U/ON*U...	B
TAN07R125M38.1-08N	125	122.3	8	80	63	64.4	38.1	38	15.9	10	2.5	without	SN*U/ON*U...	B
TAN07R125M38.1-12N	125	122.3	12	80	63	64.4	38.1	38	15.9	10	2.5	without	SN*U/ON*U...	B
TAN07R125M40.0E08N	125	122.3	8	71	63	64.4	40	29	16.4	9	2.5	without	SN*U/ON*U...	B
TAN07R125M40.0E12N	125	122.3	12	71	63	64.4	40	29	16.4	9	2.5	without	SN*U/ON*U...	B

Dimension when using positive type inserts (OWMT)

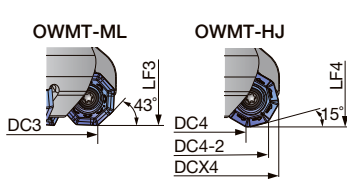

Metric	OWMT-ML		OWMT-HJ			
	DC3	LF3	DC4	DC4-2	DCX4	LF4
TAN07R063M...	63.5	41	55.7	67.2	76.4	41.4
TAN07R080M...	80.5	51	72.7	84.2	93.4	51.4
TAN07R100M...	100.5	51	92.7	104.2	113.4	51.4
TAN07R125M...	125.5	64	117.7	129.2	138.4	64.4
TAN07R160M...	160.5	64	152.7	164.2	173.4	64.4
TAN07R200M...	200.5	64	192.7	204.2	213.4	64.4
TAN07R250M...	250.5	64	242.7	254.2	263.4	64.4
TAN07R315M...	315.5	64	307.7	319.2	328.4	64.4

Note: OWMT08 inserts can be only used with screw on type cutters.

**Arbor type**

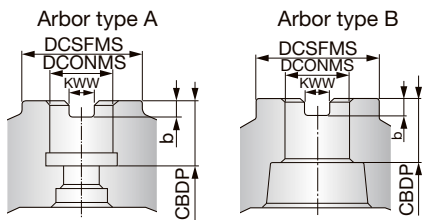

**SPARE PARTS**

Designation	Clamping screw	Grip (Optional)	Lubricant (Optional)	Shell locking bolt 1	Shell locking bolt 2	Torx bit (Optional)
TAN07R080M25.4**N	SRM5X0.8IP20X+ACROLYTE	(H-TB)	(M-1000)	-	CM12X30H	(BLD IP20/S7)
TAN07R100M31.7**N	SRM5X0.8IP20X+ACROLYTE	(H-TB)	(M-1000)	TMBA-M16H	-	(BLD IP20/S7)
TAN07R125M**N	SRM5X0.8IP20X+ACROLYTE	(H-TB)	(M-1000)	TMBA-M20H	-	(BLD IP20/S7)

Recommended clamping torque : SRM5X0.8IP20X+ACROLYTE = 7.5 N·m

## TAN07-W

High density face mill, with wedge clamp system

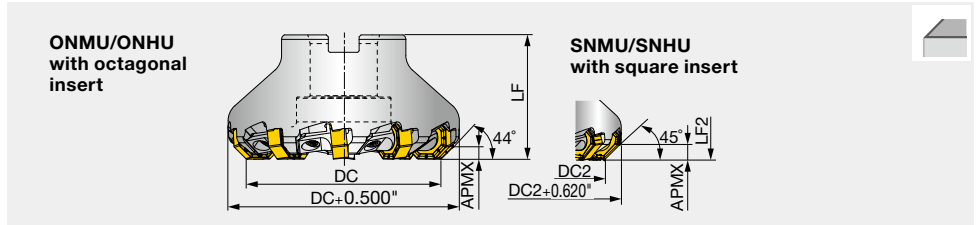

Inch	DC	DC2	CICT	DCSFMS	LF	LF2	DCONMS	CBDP	KWW	b	WT (lb)	Air hole	Insert	Arbor type
TAN07R250U0075A08W	2.500	2.394	8	1.750	1.750	1.805	0.750	0.750	0.313	0.188	1.600	Without	SN*U/ON*U...	B
TAN07R300U0100A10W	3.000	2.894	10	2.000	2.000	2.055	1.000	0.750	0.375	0.219	2.000	Without	SN*U/ON*U...	B
TAN07R400U0150A14W	4.000	3.894	14	2.400	2.000	2.055	1.500	1.000	0.625	0.375	2.800	Without	SN*U/ON*U...	B
TAN07R500U0150A18W	5.000	4.894	18	2.400	2.500	2.555	1.500	1.000	0.625	0.375	4.300	Without	SN*U/ON*U...	B
TAN07R600U0200A22W	6.000	5.894	22	4.000	2.500	2.555	2.000	1.000	0.750	0.438	6.800	Without	SN*U/ON*U...	B
TAN07R800U0250A28W	8.000	7.894	28	5.300	2.500	2.555	2.500	1.400	1.000	0.531	13.500	Without	SN*U/ON*U...	C

OWMT insert cannot be used with a wedge clamp type cutter.

### Arbor type

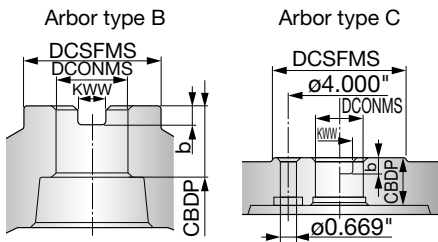

### SPARE PARTS

Designation	Grip	Lubricant (Optional)	Torx bit	Wedge	Clamping screw	Shell locking bolt (Optional)
TAN07R250U**W	H-TBS	(M-1000)	BLD IP15/S7	CL ARM-10-TUNG1	DS-6P	(C0.375X1.125H)
TAN07R300U**W	H-TBS	(M-1000)	BLD IP15/S7	CL ARM-10-TUNG1	DS-6P	(C0.500X1.375H)
TAN07R400U**W, TAN07R500U**W	H-TBS	(M-1000)	BLD IP15/S7	CL ARM-10-TUNG1	DS-6P	(TMBA-0.750H)
TAN07R600U**W, TAN07R800U**W	H-TBS	(M-1000)	BLD IP15/S7	CL ARM-10-TUNG1	DS-6P	-

## TAN07-W

High density face mill, with wedge clamp system

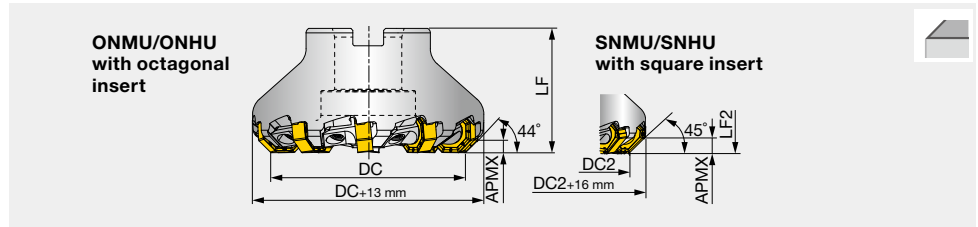

Metric	DC	DC2	CICT	DCSFMS	LF	LF2	DCONMS	CBDP	KWW	b	WT(kg)	Air hole	Insert	Arbor type
TAN07R063M22.0E08W	63	60.3	8	41	40	41.4	22	20	10.4	6.3	0.6	Without	SN*U/ON*U...	B
TAN07R080M25.4-10W	80	77.3	10	50	50	51.4	25.4	26	9.5	6	1	Without	SN*U/ON*U...	B
TAN07R080M27.0E10W	80	77.3	10	50	50	51.4	27	25	12.4	7	1.1	Without	SN*U/ON*U...	B
TAN07R100M31.7-14W	100	97.3	14	60	50	51.4	31.75	32	12.7	8	1.3	Without	SN*U/ON*U...	B
TAN07R100M32.0E14W	100	97.3	14	60	50	51.4	32	28.5	14.4	8	1.6	Without	SN*U/ON*U...	B
TAN07R125M38.1-18W	125	122.3	18	80	63	64.4	38.1	38	15.9	10	2.8	Without	SN*U/ON*U...	B
TAN07R125M40.0E18W	125	122.3	18	71	63	64.4	40	29	16.4	9	2.5	Without	SN*U/ON*U...	B
TAN07R160M50.8-22W	160	157.3	22	100	63	64.4	50.8	38	19	11	4	Without	SN*U/ON*U...	B
TAN07R160M40.0E22W	160	157.3	22	100	63	64.4	40	29	16.4	9	3.6	Without	SN*U/ON*U...	D
TAN07R200M60.0E28W	200	197.3	28	135	63	64.4	60	39	25.7	14	5.8	Without	SN*U/ON*U...	C

OWMT insert cannot be used with a wedge clamp type cutter.

### Arbor type

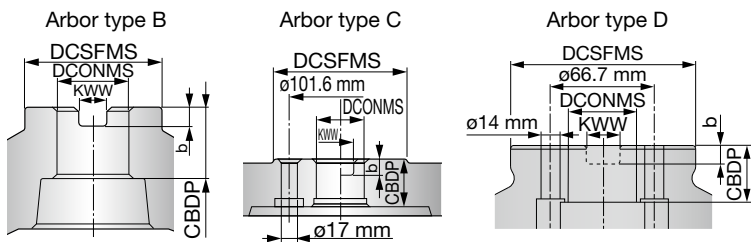

### SPARE PARTS

Designation	Grip	Lubricant (Optional)	Wedge	Wedge fixing screw	Torx bit
TAN07-W	H-TBS	(M-1000)	CL ARM-10-TUNG I	DS-6P	BLD IP15/S7

## INSERT

### ONMU/ONHU0705-MJ / -ML

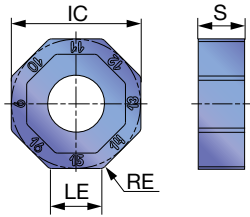

### ONHU0705-W

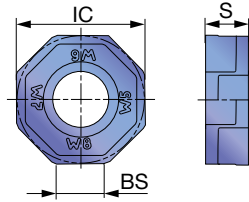

### SNMU/SNHU1706 -MJ / -ML

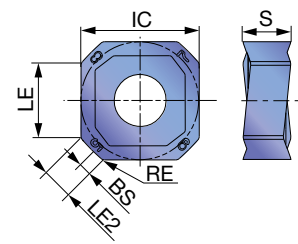

### SNHU1706-W

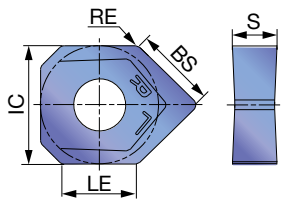

### OWMT0807-ML

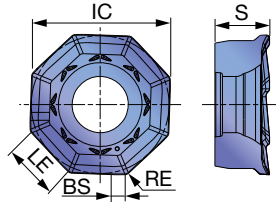

### OWMT0807-HJ

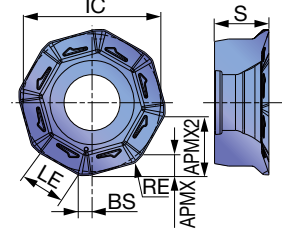

<b>P</b> Steel	☆	☆	☆	☆	★	☆				★
<b>M</b> Stainless		☆			★	☆				★
<b>K</b> Cast iron	★			☆		★	☆	★		
<b>N</b> Non-ferrous										
<b>S</b> Superalloys		☆		☆		★				
<b>H</b> Hard materials					☆	☆		★		

★ : First choice  
☆ : Second choice

Designation	RE	APMX	Coated							LE	S	LE2	IC	BS	APMX2						
			AH120	AH130	AH140	AH725	AH3135	AH3225	AH8015							T1115	T1215	T3225			
ONMU0705ANPN-MJ	0.031	0.187		●	●	●	●	●	●	●	●	●	●	●	●	0.283	0.244	-	0.681	-	-
ONHU0705ANPN-MJ	0.031	0.187			●	●										0.283	0.244	-	0.681	-	-
ONMU0705ANPN-ML	0.031	0.187	●													0.283	0.244	-	0.681	-	-
ONHU0705ANTN-ML	0.031	0.187	●		●	●										0.283	0.244	-	0.681	-	-
ONHU0705ANPR-W *	-	0.187	●													0.283	0.228	-	0.689	0.252	-
OWMT0807ZNER-HJ	0.047	0.059						●								-	0.291	-	0.748	0.039	0.295
OWMT0807AAER-ML	0.031	0.138		●				●								0.205	0.291	-	0.744	0.047	-
SNMU1706ANPR-MJ	0.031	0.295			●	●	●	●	●	●	●	●	●	●	●	0.433	0.275	0.173	0.681	0.071	-
SNHU1706ANPR-MJ	0.031	0.295			●	●										0.433	0.275	0.173	0.681	0.071	-
SNMU1706ANTR-ML	0.031	0.295	●					●								0.433	0.275	0.173	0.681	0.071	-
SNHU1706ANTR-ML	0.031	0.295	●													0.433	0.275	0.173	0.681	0.071	-
SNHU1706ANFN-W *	0.016	0.295	●													0.681	0.256	-	0.681	0.433	-

\* Pay attention to the wiper insert installation procedure below.

●: New product  
●: Line up

## ATTENTION FOR WIPER INSERTS

### ONHU0705ANPR-W

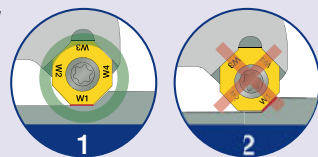

Attach only one wiper insert on the cutter and make sure the wiper edge faces the machining surface.  
Feed rate:  $f < 0.217$  ipr

### SNHU1706ANFN-W

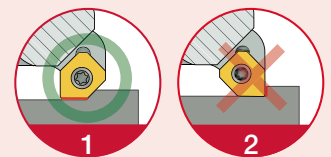

Attach only one wiper insert on the cutter and make sure the wiper edge faces the machining surface.  
Feed rate:  $f < 0.374$  ipr

## STANDARD CUTTING CONDITIONS

### Negative type



ISO	Workpiece material	Hardness	Priority	Recommendation		Cutting speed Vc (sfm)	Feed per tooth fz (ipt)
				Grade	Chipbreaker		
P	Low carbon steel 1015, etc.	- 200 HB	First choice	AH3225	MJ	328 - 820	0.008 - 0.020
		- 200 HB	Fracture resistance	AH3135	MJ	328 - 820	0.008 - 0.020
		- 200 HB	Wear resistance	T3225	MJ	656 - 1148	0.008 - 0.016
		- 200 HB	Low cutting force	AH3225	ML	328 - 820	0.008 - 0.016
	High carbon steel 1045, 1055, etc.	200 - 300 HB	First choice	AH3225	MJ	328 - 755	0.008 - 0.016
		200 - 300 HB	Fracture resistance	AH3135	MJ	328 - 755	0.008 - 0.016
		200 - 300 HB	Wear resistance	T3225	MJ	591 - 984	0.008 - 0.016
		200 - 300 HB	Low cutting force	AH3225	ML	328 - 755	0.008 - 0.016
	Alloy steel 4140, etc.	150 - 330 HB	First choice	AH3225	MJ	328 - 656	0.008 - 0.016
		150 - 330 HB	Wear resistance	AH3135	MJ	328 - 656	0.008 - 0.016
		150 - 330 HB	Low cutting force	T3225	MJ	492 - 820	0.008 - 0.016
		150 - 330 HB	First choice	AH3225	ML	328 - 656	0.008 - 0.016
M	Stainless steel S30400, etc.	- 200 HB	Fracture resistance	AH3135	MJ	328 - 656	0.004 - 0.012
		- 200 HB	Wear resistance	T3225	MJ	328 - 820	0.004 - 0.012
K	Gray cast iron No.35B, No.45B, etc.	150 - 250 HB	First choice	AH8015	MJ	328 - 820	0.004 - 0.020
		150 - 250 HB	Wear resistance	T1215	MJ	492 - 984	0.004 - 0.020
		150 - 250 HB	Low cutting force	AH8015	ML	328 - 820	0.004 - 0.020
	Ductile cast iron 60-40-18, etc.	150 - 300 HB	First choice	AH8015	MJ	262 - 656	0.004 - 0.020
		150 - 300 HB	Wear resistance	T1215	MJ	328 - 984	0.004 - 0.020
		150 - 300 HB	Low cutting force	AH8015	ML	262 - 656	0.004 - 0.020
S	Titanium alloy Ti-6Al-4V, etc.	- HRC 40	First choice	AH3135	ML	98 - 197	0.004 - 0.012
	Heat resistant alloy Inconel718, etc.	- HRC 40	First choice	AH8015	ML	33 - 131	0.002 - 0.006
H	Hardened steel	40 - 50 HRC	First choice	AH8015	MJ	262 - 427	0.004 - 0.008
		40 - 50 HRC	Fracture resistance	AH3225	MJ	262 - 427	0.004 - 0.008
		50 - 60 HRC	First choice	AH8015	MJ	164 - 230	0.002 - 0.004

### Positive type

ISO	Workpiece material	Hardness	Priority	Grade	Cutting speed Vc (sfm)	Feed per tooth : fz (ipt)	
						ML	HJ*
P	Low carbon steel 1015, etc.	- 200 HB	First choice	AH3135	328 - 984	0.004 - 0.016	0.02 - 0.059
	High carbon steel 1045, 1055, etc.	200 - 300 HB	First choice	AH3135	328 - 755	0.004 - 0.012	0.02 - 0.059
	Alloy steel 4140, etc.	150 - 330 HB	First choice	AH3135	328 - 656	0.004 - 0.012	0.02 - 0.059
M	Stainless steel S30400, etc.	- 200 HB	First choice	AH3135	328 - 492	0.004 - 0.012	-
		- 200 HB	Fracture resistance	AH130	328 - 492	0.004 - 0.012	0.012 - 0.028
K	Gray cast iron No.35B, No.45B, etc.	150 - 250 HB	First choice	AH3135	328 - 820	0.004 - 0.016	-
	Ductile cast iron 60-40-18, etc.	150 - 250 HB	First choice	AH3135	262 - 656	0.004 - 0.012	0.02 - 0.059
S	Titanium alloy Ti-6Al-4V, etc.	- HRC 40	First choice	AH3135	98 - 197	0.004 - 0.012	0.02 - 0.059
		- HRC 40	Fracture resistance	AH130	98 - 197	0.004 - 0.012	0.012 - 0.028
	Heat resistant alloy Inconel718, etc.	- HRC 40	First choice	AH3135	33 - 131	0.002 - 0.001	-
		- HRC 40	Fracture resistance	AH130	33 - 131	0.002 - 0.001	0.004 - 0.012
H	Hardened steel	40 - 50 HRC	First choice	AH3135	262 - 427	-	-
		50 - 60 HRC	First choice	AH3135	164 - 230	-	0.001 - 0.003

\* Apply 20% of recommended feed when using HJ insert with ap over 0.059"

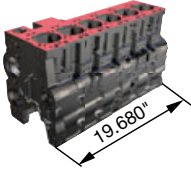
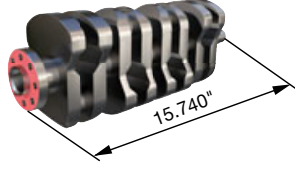
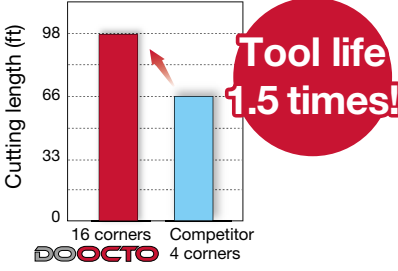
## PRACTICAL EXAMPLES

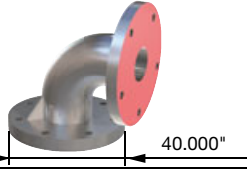
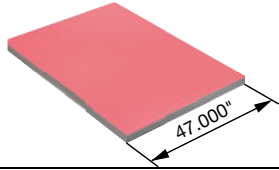
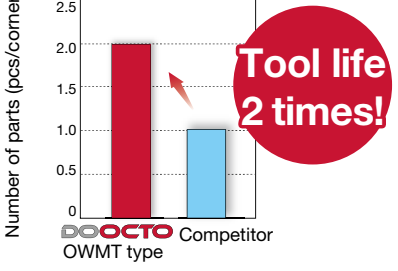
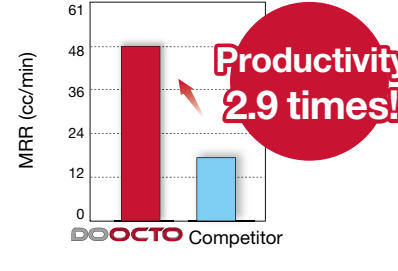
Workpiece type		Cylinder block	Crank shaft
Cutter		TAN07R600U0200A15 ( $\phi 6.000''$ , CICT = 15)	TAN07R400U0150A07 ( $\phi 4.000''$ , CICT = 7)
Insert		ONHU0705ANTN-ML	ONMU0705ANPN-ML
Grade		AH120	AH3135
Workpiece material		No.300B 	
Cutting conditions		590 0.007 $\rightarrow$ 0.008 30.000 $\rightarrow$ 43.000 0.118 4.000 Face milling Dry Vertical M/C, BT50	260 0.007 13.000 0.120 3.000 Face milling Wet Specialized machine
Results		 <b>Tool life 1.5 times!</b> DoOcto achieves 1.4 times higher productivity and reduces machining cost by 40% compared to the competitor.	 <b>Tool life 1.8 times!</b> Tool life of AH3135 is 1.8 times longer than the competitor.
Workpiece type		Elbow	Mold base
Cutter		TAN07R800U0250A12 ( $\phi 8.000''$ , CICT = 12)	TAN07R500U0150A08 ( $\phi 5.000''$ , CICT = 8)
Insert		OWMT0807AAER-ML	OWMT0807ZNER-HJ
Grade		AH3135	AH3135
Workpiece material		Cast stainless steel 	Low carbon steel (Structural steel) 
Cutting conditions		230 0.008 11.000 0.040 7.200 Face milling Wet Horizontal M/C, BT50	660 0.060 242.000 0.040 4.400 Face milling Dry Vertical M/C, BT50
Results		 <b>Tool life 2 times!</b> OWMT insert doubles tool life and provides better surface finish compared to the competitor.	 <b>Productivity 2.9 times!</b> DoOcto performs at remarkable metal removal rate due to high-feed machining.

# MEMO

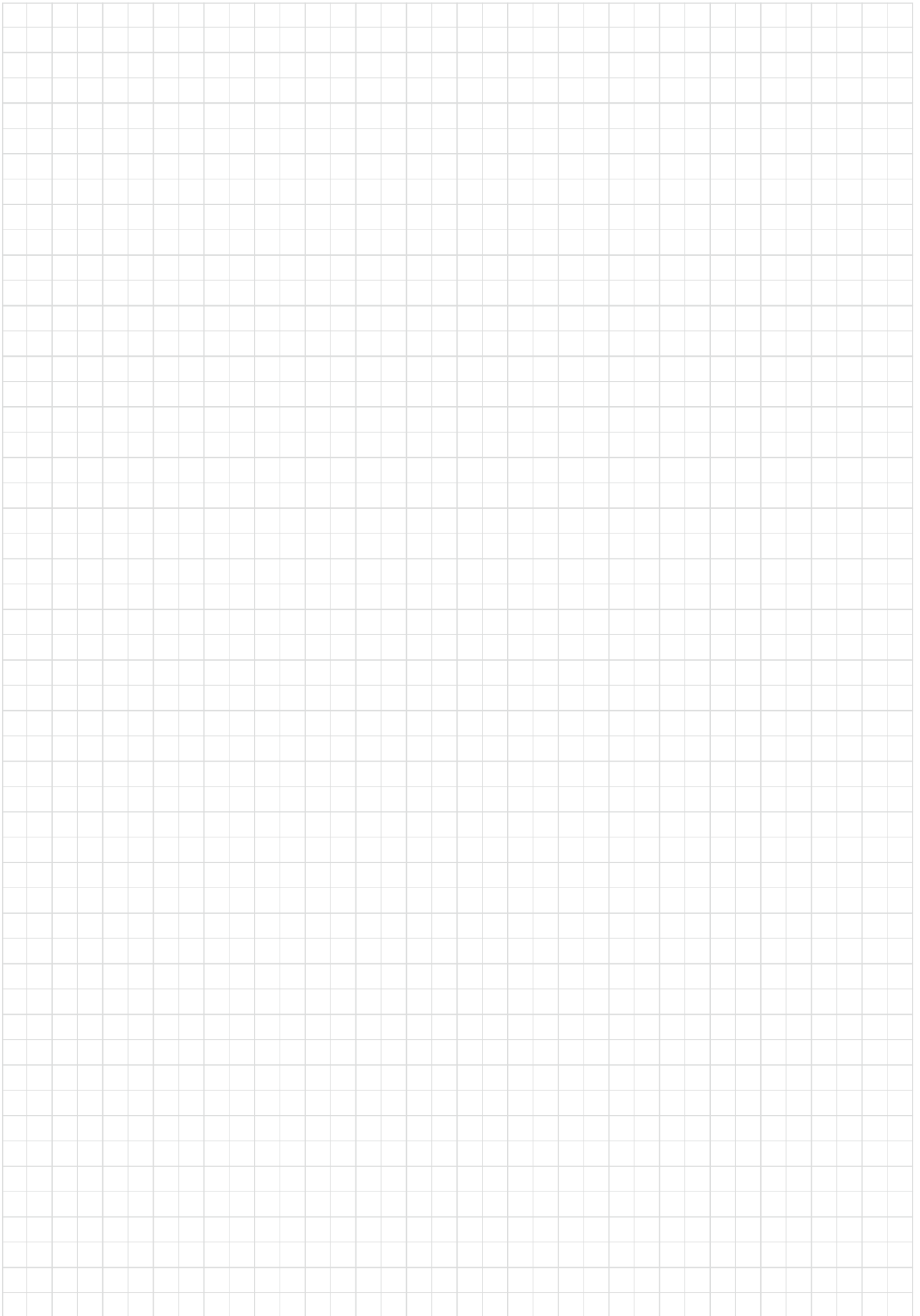

# Tungaloy-NTK America Inc.

## United States

3726 N Ventura Drive, Arlington Heights, IL 60004, U.S.A.

Inside Sales: +1-888-554-8394

Technical Support: +1-888-554-8391

Fax: +1-888-554-8392

tungaloy.com/us

## Canada

432 Elgin St. Unit 3, Brantford, Ontario N3S 7P7, Canada

Phone: +1-519-758-5779 Fax: +1-519-758-5791

tungaloy.com/ca

## Mexico

C Los Arellano 113, Parque Industrial Siglo XXI

Aguascalientes, AGS, Mexico 20290

Phone:+52-449-929-5410 Fax:+52-449-929-5411

tungaloy.com/mx



Scan for instant  
web access



[tungaloy.com/us](http://tungaloy.com/us)

follow us at:

[facebook.com/TungaloyNTK](https://facebook.com/TungaloyNTK)

[instagram.com/tungaloyntkamerika](https://instagram.com/tungaloyntkamerika)

[linkedin.com/company/tungaloyntkamerika](https://linkedin.com/company/tungaloyntkamerika)

[tiktok.com/@tungaloyntkamerika](https://tiktok.com/@tungaloyntkamerika)

To see Tungaloy products in action visit:



[www.youtube.com/tungaloycorporation](https://www.youtube.com/tungaloycorporation)

Distributed by:



Tungaloy APP & SNS

FIND US ON THE CLOUD!  
[machingcloud.com](http://machingcloud.com)



AS9100 Certified  
78006  
2015.11.04  
ISO 14001 Certified  
EC97J1123  
1997.11.26