

MODEL IN SCALE : Free

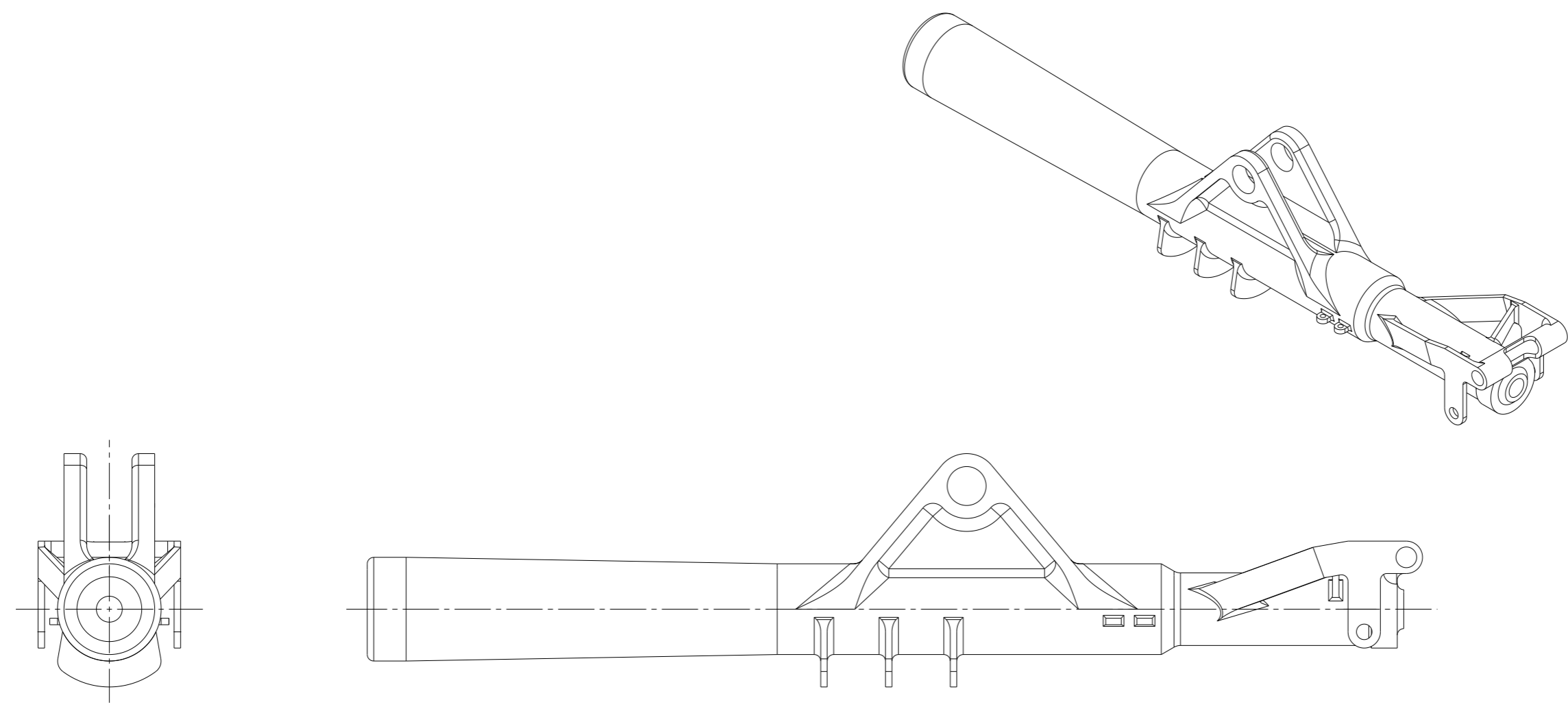

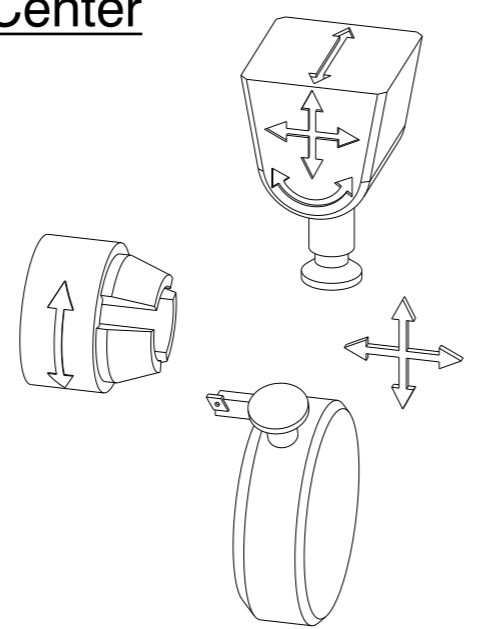



MACHINE : 5 Axis Mill Turn Center

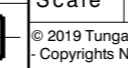

LANDING GEAR

WORKPIECE MATERIAL -Ti-6Al-4V, Ti-5553, 300M

Unspecified Tolerances	Draw		Customer: TUNGALOY	Japan	 Dwg. No. 32448865-HCL Page 1 Rev. 1 Of 1 No. 1
	Design		Designation: LAYOUT-LANDING GEAR-62312		
Dim.s: -.-	Check		Process	Layout.	Reg.No. 62312/1 A3L
	Angles: -.-	Appr.	Lead Drawing		
 	Scale	-.-			
	© 2019 Tungaloy Corporation - Copyrights Notice				FL-40032524

MODEL IN SCALE : Free TOOLS IN SCALE 1:2

**CUT101**  
**OD Turning Rough**  
 ASBNL3232P19-A  
 SNMG190616-HRM AH8015

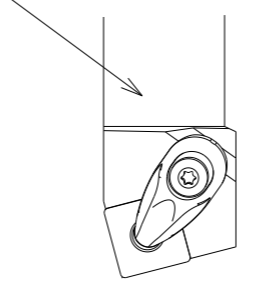

**Turning A**  
**AH8000**

**CUT101**  
**OD Turning Rough**  
 PPXOL3232P13-HD  
 POMG130612-MNW AH8015

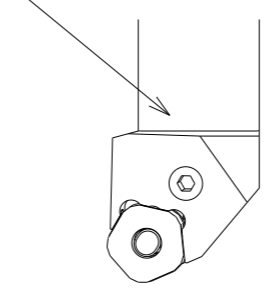

**TurnTenFeed**  
**AH8000**

**CUT101** <sup>1</sup>  
**OD Turning Rough**  
 C6ACLNL45065-16N  
 CNMG160608-HRM AH8015

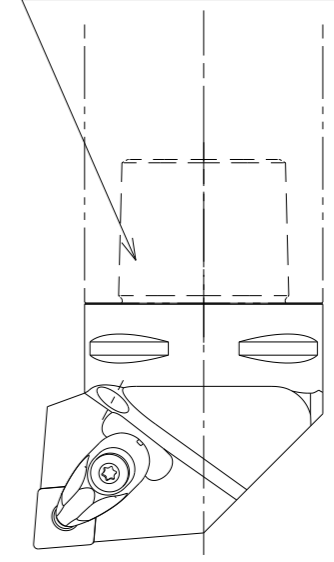

**TungCap**  
**TungTurn-Jet**  
**AH8000**

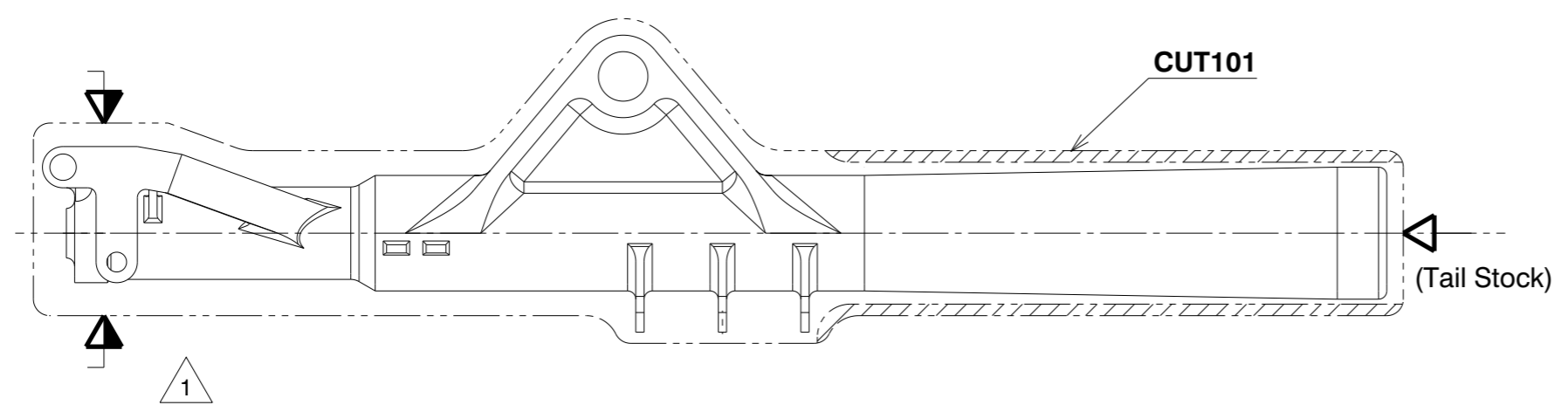

**Lathe : O.D. Rough Turning**

Unspecified Tolerances	Draw	--	--	Customer: TUNGALOY	Japan	
	Design			Designation: LAYOUT OP100-LANDING GEAR		
Dim.s:	Check			Process		Page 1
	Appr.			Concept	Layout.	Rev. No. 1
Angles:	Scale	-		-		Of 1
				FL-40032524		Reg.No. 62312/1
				© 2019 Tungaloy Corporation - Copyrights Notice		A3L

MODEL IN SCALE : Free TOOLS IN SCALE 1:3

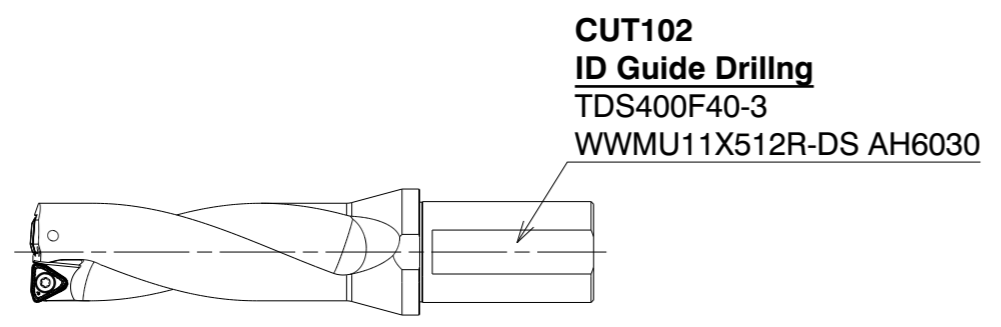

**TungSix-Drill**

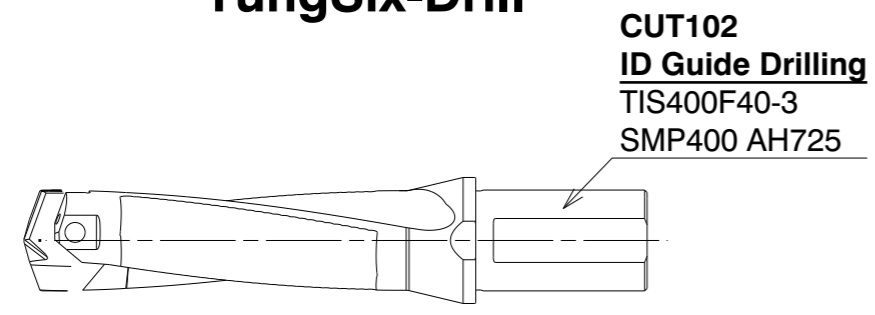

**DrillForceMeister**

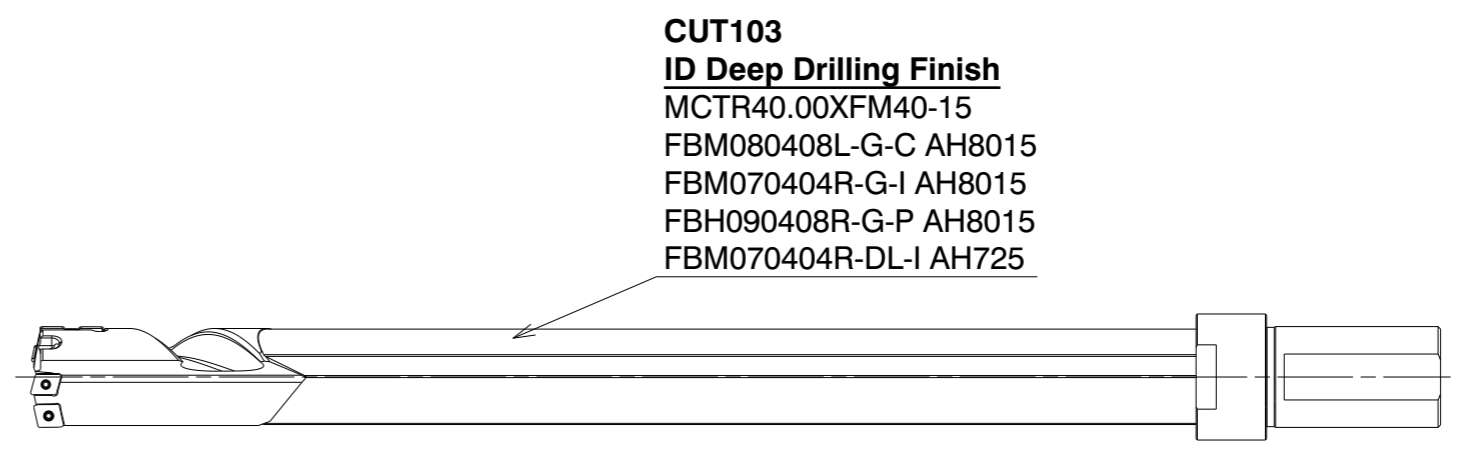

**DeepTriDrill  
AH8000**

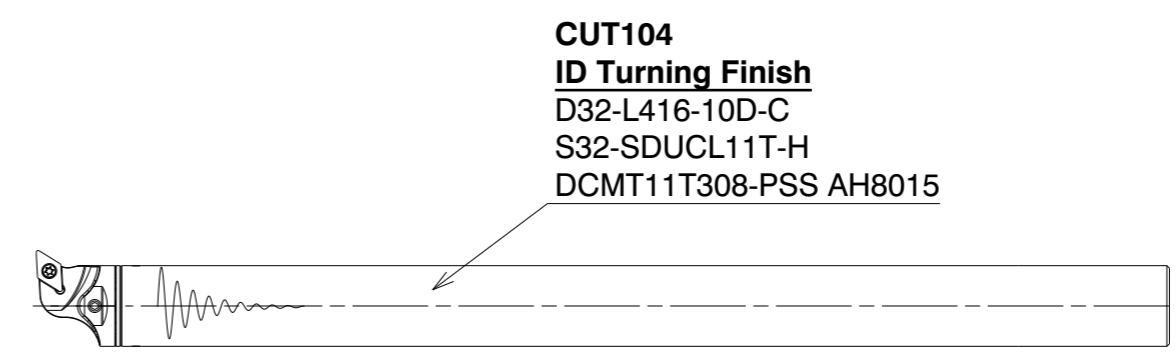

**BoreMeister  
AH8000**

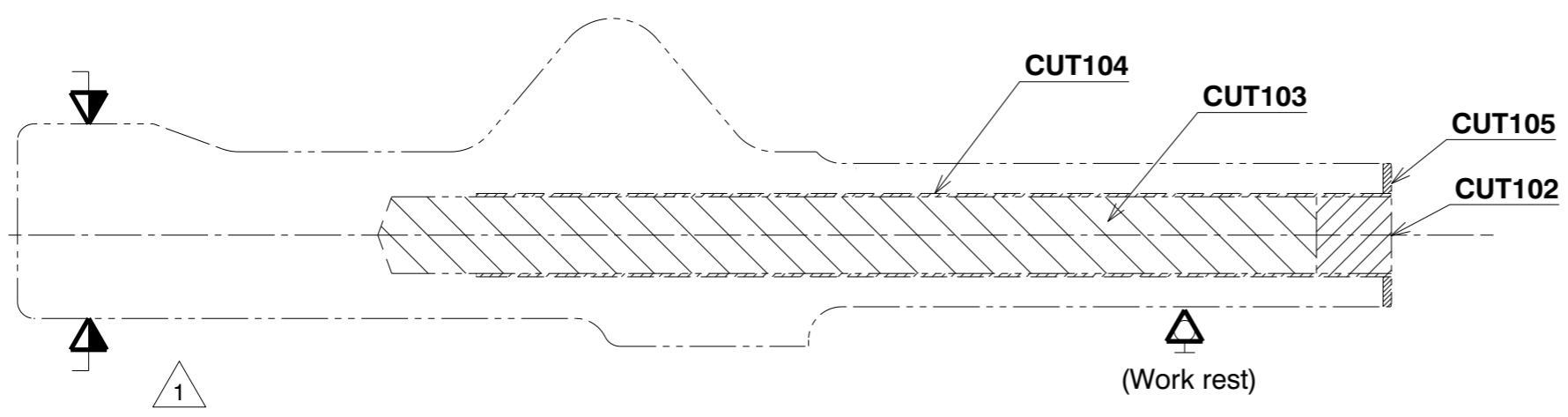

**CUT 105  
End Face Turning Finish**  
PCLNL2525M12-CHP  
CNMG120408-HRF AH8015

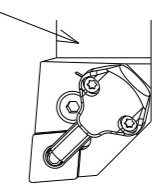

**TungTurn-Jet  
AH8000**

**Lathe : I.D. Turning / Face Turning**

Unspecified Tolerances	Draw	-.	-.	Customer: TUNGALOY	Japan	
Dim.s:	Design			Designation: <b>LAYOUT OP100-LANDING GEAR</b>		
Angles:	Check			Process	Layout.	Page 1 Of 1
	Appr.			Concept		Rev. No.
	Scale	-				Reg.No. 62312/1
		© 2019 Tungaloy Corporation Copyrights Notice		FL-40032524		A3L

MODEL IN SCALE : Free TOOLS IN SCALE 1:3

**CUT 106**  
**OD Turning Finish**  
 PDJNL2525M15-CHP  
 DNMG150408-HRF AH8015

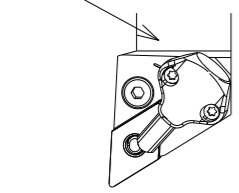

**TungTurn-Jet**  
**AH8000**

**CUT106**  
**OD Turning Finish**  
 C6PDJNL45065-15-CHP  
 DNMG150408-HRF AH8015

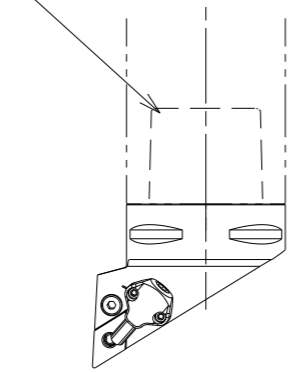

**TungCap**  
**TungTurn-Jet**  
**AH8000**

**CUT107** <sup>1</sup>  
**OD High Feed Milling Rough**  
 TXSW09M063B22.0R06  
 SWMT0904ZER-MM AH130

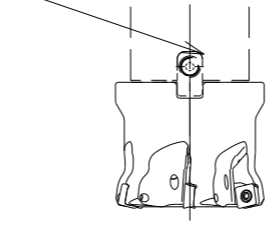

**MillQuadFeed**

**CUT107**  
**OD High Feed Milling Rough**  
 TXN06R063M22.0E06  
 LNMU06X5ZER-ML AH130

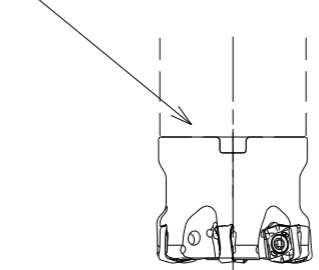

**DoFeed**

**CUT108** <sup>1</sup>  
**OD High Feed Milling Rough**  
 HXSW09M032M16R04  
 SWMT0904ZER-MM AH3135

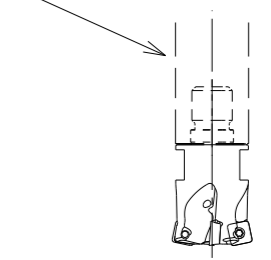

**MillQuadFeed**  
**TungFlex**

**CUT107**  
**OD High Feed Milling Rough**  
 TRP16R066M27.0E05  
 RPMT1606EN-ML AH4035

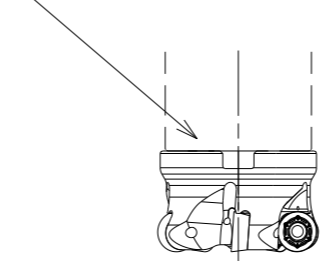

**FixR-Mill**

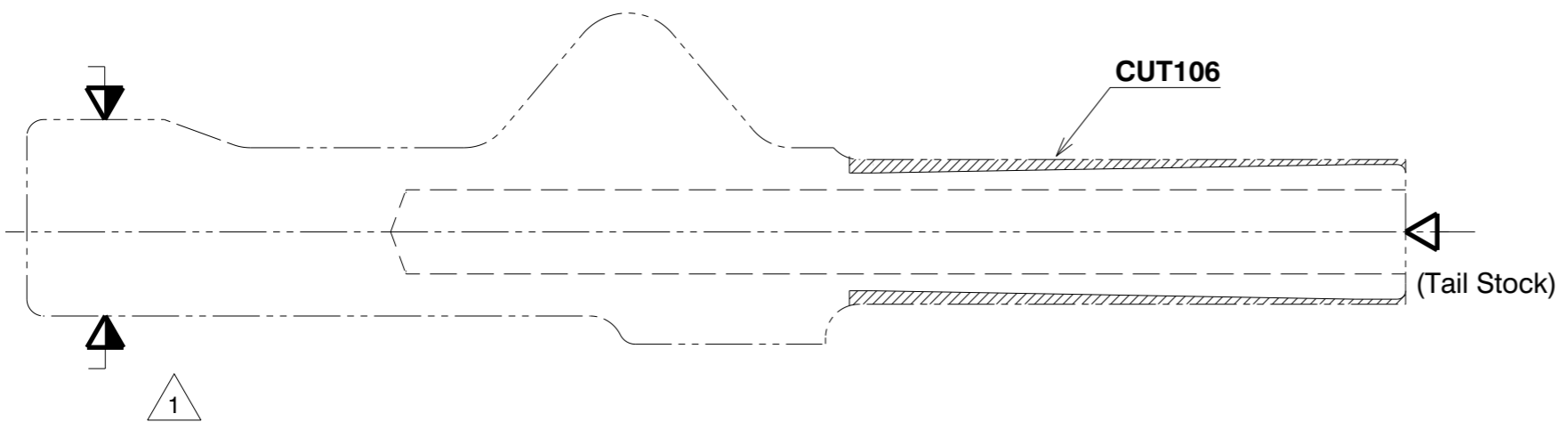
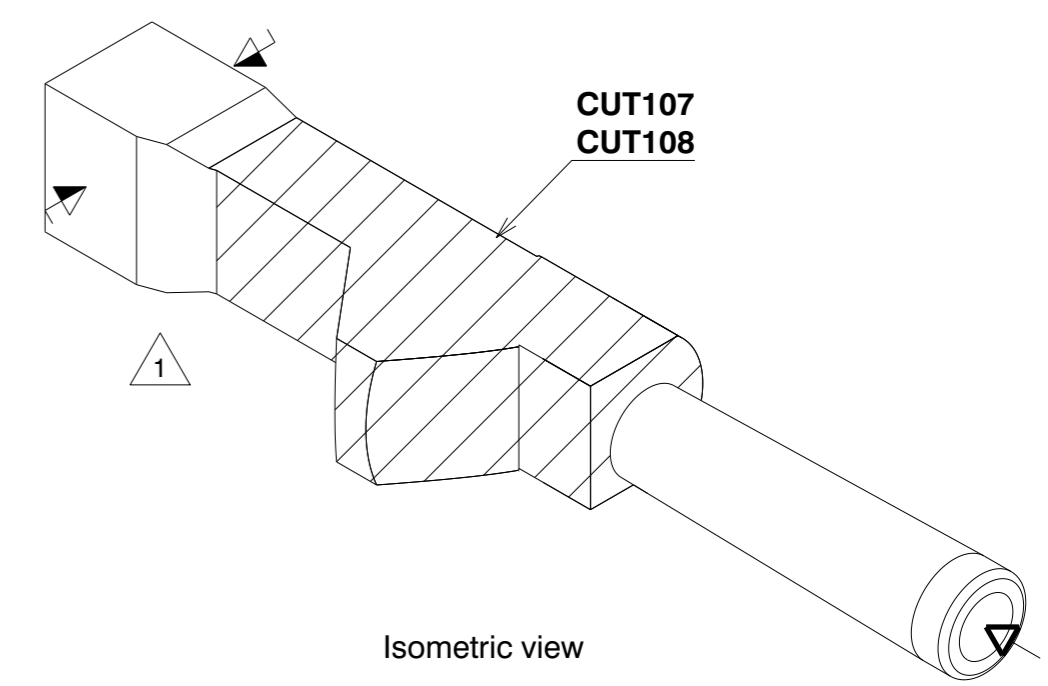

**Lathe : O.D. Turning Finish**  
**M/C : High Feed Milling Rough**

Unspecified Tolerances	Draw	--	--	Customer: TUNGALOY	Japan	
	Design			Designation: LAYOUT OP100-LANDING GEAR		
Dim.s:	Check			Process		Page 1
	Appr.			Concept		Of 1
Angles:	Scale	-		Layout.		Rev. No. <sup>1</sup>
				-		Reg.No. 62312/1
	© 2019 Tungaloy Corporation - Copyrights Notice			FL-40032524		A3L

MODEL IN SCALE : Free TOOLS IN SCALE 1:3

**CUT109**   
**Out Side Profile Milling Rough**  
 TXSW09M050B22.0R07  
 SWMT0904ZER-MM AH3135

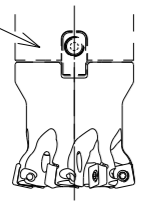

**MillQuadFeed**

**CUT109**  
**Out Side Shoulder Milling Rough**  
 TLA10R050L054M22.0E04  
 TOMT100408PDER-MJ AH120

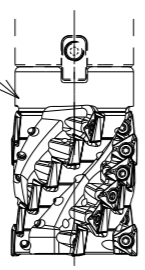

**TungTri**

**CUT109 /110**  
**Out Side Profile Milling Rough**  
 HXN03R032MM16-06-C  
 LNMU0303ZER-ML AH130

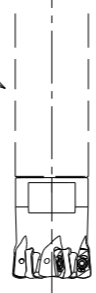

**DoFeed  
TungFlex**

**CUT111**  
**Out Side Profile Millng Finish**  
 HXLN04M025M12R03  
 LNMX0405R4-ML AH3135

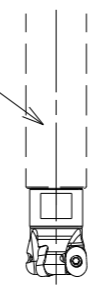

**DoTwistBall  
TungFlex**

**CUT111**  
**Out Side Profile Millng Finish**  
 HBFM16M08  
 ZFBM160R00-MJ AH725



**BallFinishNose  
TungFlex**

**CUT112**  
**Out Side Face Milling Finish**  
 TPTN12M080B27.0R08  
 TNMU120708PER-MJ AH3135

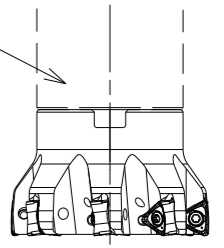

**DoForceTri**

**CUT112**   
**Out Side Face Milling Finish**  
 THSN12M080B27.0R08  
 SNMU120612EN-MM AH3135  
 SNMU120608HNEN-MM AH3135

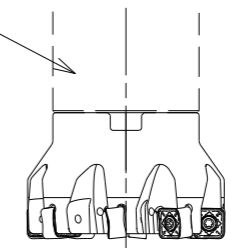

**DoQuad-Mill**

**CUT112**   
**Out Side Face Milling Finish**  
 TPA10R080M27.0E07  
 TOET100408PDER-MJ AH3135

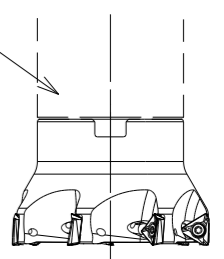

**TungTri**

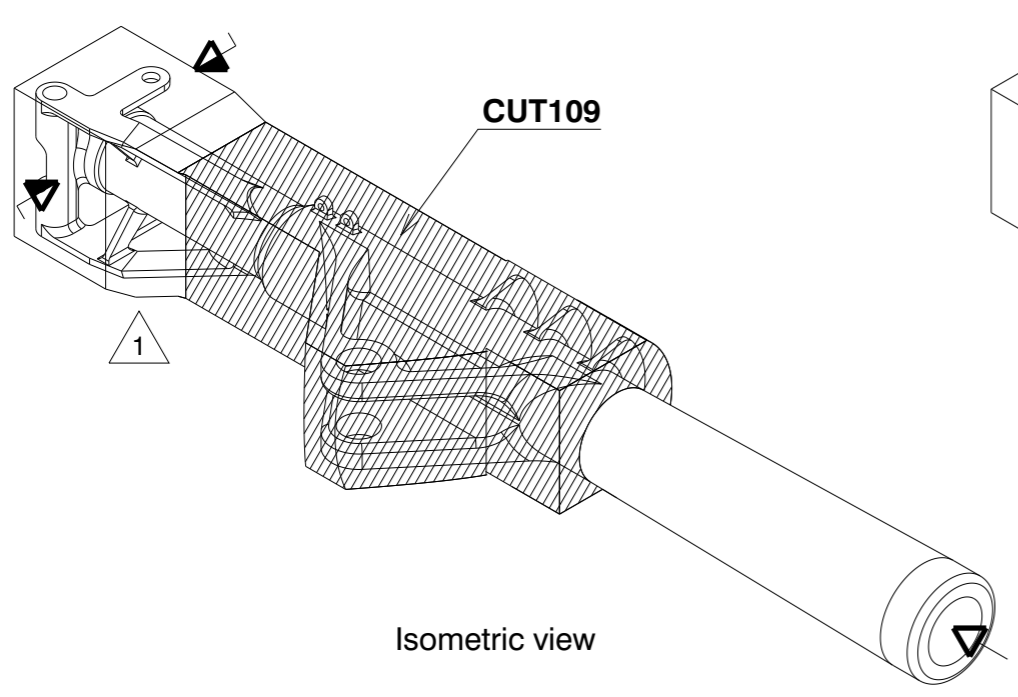

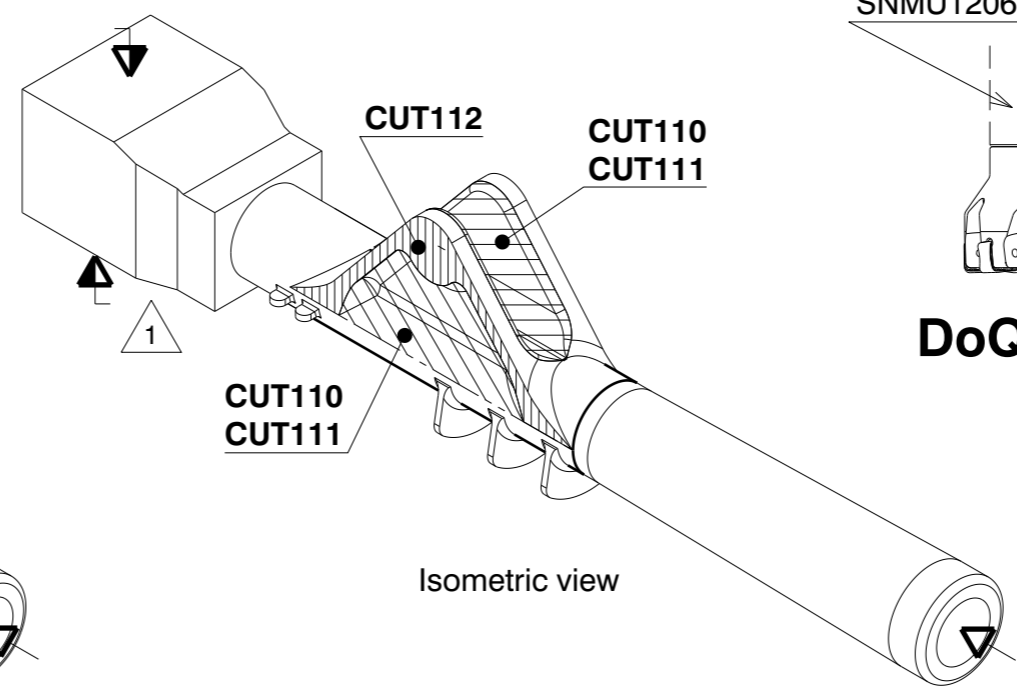

Isometric view



Isometric view

**M/C : Out side Millng Rough / Finish**

Unspecified Tolerances	Draw	--	--	Customer: TUNGALOY	Japan	
	Design			Designation: LAYOUT OP100-LANDING GEAR		
Dim.s:	Check			Process		Page 1
	Appr.			Concept		Rev. 
Angles:	Scale	-		Layout.		Of 1
				-		No. 1
	© 2019 Tungaloy Corporation - Copyrights Notice			Reg.No. 62312/1		A3L
				FL-40032524		

MODEL IN SCALE : Free TOOLS IN SCALE 1:3

**CUT113**  
**Out Side Profile Millng Finish**  
 HXLN04M025M12R03  
 LNMX0405R4-ML AH3135

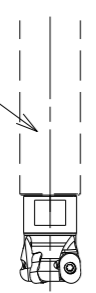

**DoTwistBall  
TungFlex**

**CUT113**   
**Out Side Profile Millng Finish**  
 HBFM20M10  
 ZFBM200R00-MJ AH725



**BallFinishNose  
TungFlex**

**CUT113**  
**Out Side Profile Millng Finish**  
 VSSD16L090S10-C  
 VBD160L09.5-BG-02S10AH725

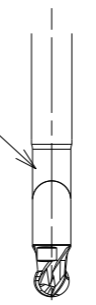

**TungMeister**

**CUT114**  
**Holemaking Rough**  
 TDS245F25-3  
 WWMU060306R-DS AH6030

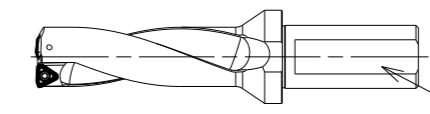

**TungSix-Drill**

**CUT114**  
**Holemaking Rough**  
 TID240F32-3  
 DMP246 AH725

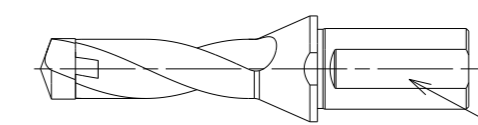

**DrillMeister**

**CUT117**   
**Shoulder Milling Finish**  
 TECK120H4M-24C12CF-R06 AH725



**SolidMeister  
VariableMeister**

**CUT115**  
**Chamfering Finish**  
 EASD05M016C16.0R04  
 SDMT050204PN-MJ AH725

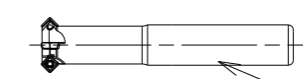

**TungQuad**

**CUT116**  
**Reaming**  
 TRM-T8-R20-5  
 HRM-25.000-BL-T8 AH725

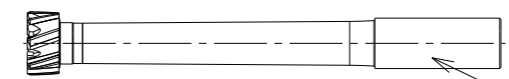

**ReamMeister**

**CUT116**  
**Boring Finish**  
 206.064.025.045  
 254.025.006.115  
 CCMT060204-PSS AH8015

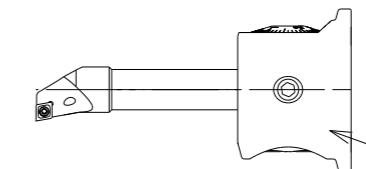

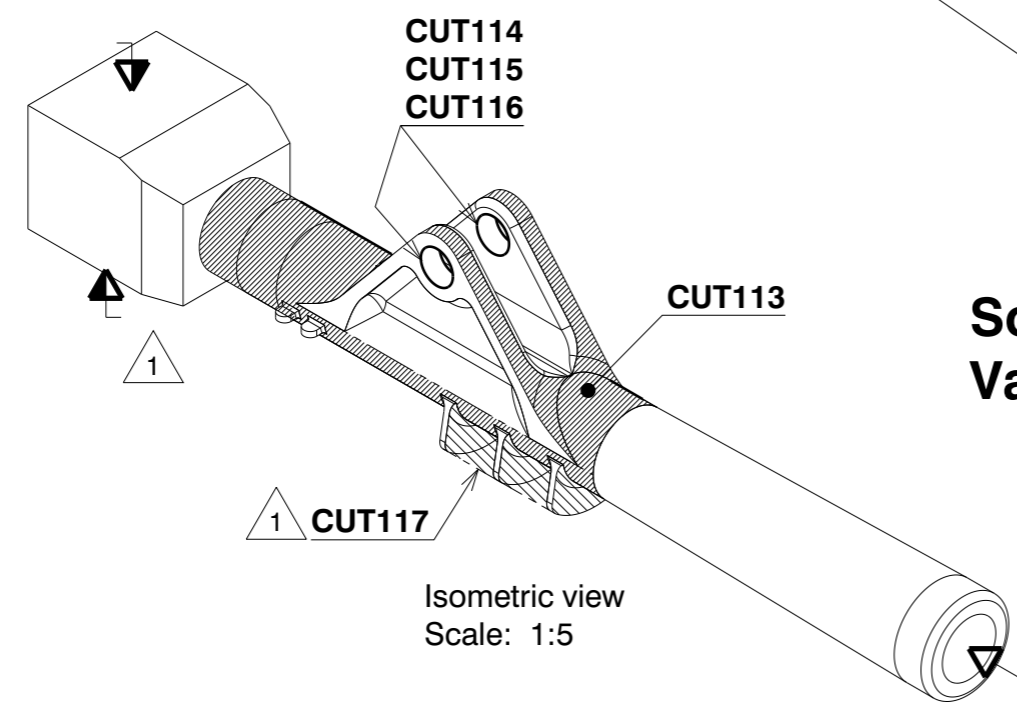

**SwissTool  
AH8000**



Isometric view  
Scale: 1:5

**M/C : Profile Millng Finish / Holemaking**

Unspecified Tolerances	Draw	-. -.	-. -.	Customer: TUNGALOY	Japan	
Dim.s:	Design			Designation:		
Angles:	Check			LAYOUT OP100-LANDING GEAR		32448865-HC4
	Appr.			Process	Layout.	Page 1
	Scale	-		Concept		Of 1
				-		Rev. No. 
				FL-40032524		Reg.No.
						62312/1
						A3L

MODEL IN SCALE : Free TOOLS IN SCALE 1:3

**CUT201**   
**Out Side Profile Milling Rough**  
 TXSW09M050B22.0R07  
 SWMT0904ZER-MM AH3135

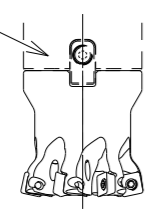

**MillQuadFeed**

**CUT201**  
**Out side Profile Milling Rough**  
 HXLS02M016M08R05  
 LSMT0202ZER-HM AH3225

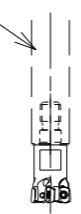

**TungForceFeed**  
**TungFlex**

**CUT202**  
**Out Side Profile Milling Finish**  
 HXLN04M025M12R03  
 LNMX0405R4-ML AH3135

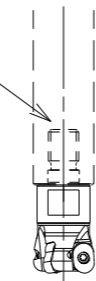

**DoTwistBall**  
**TungFlex**

**CUT202**  
**Out Side Profile Milling Finish**  
 HBFM16M08  
 ZFBM160R00-MJ AH725

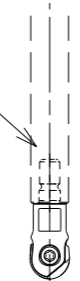

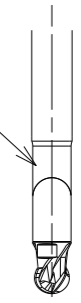

**BallFinishNose**  
**TungFlex**

**CUT202**  
**Out Side Profile Milling Finish**  
 VSSD16L090S10-C  
 VBD160L09.5-BG-02S10AH725

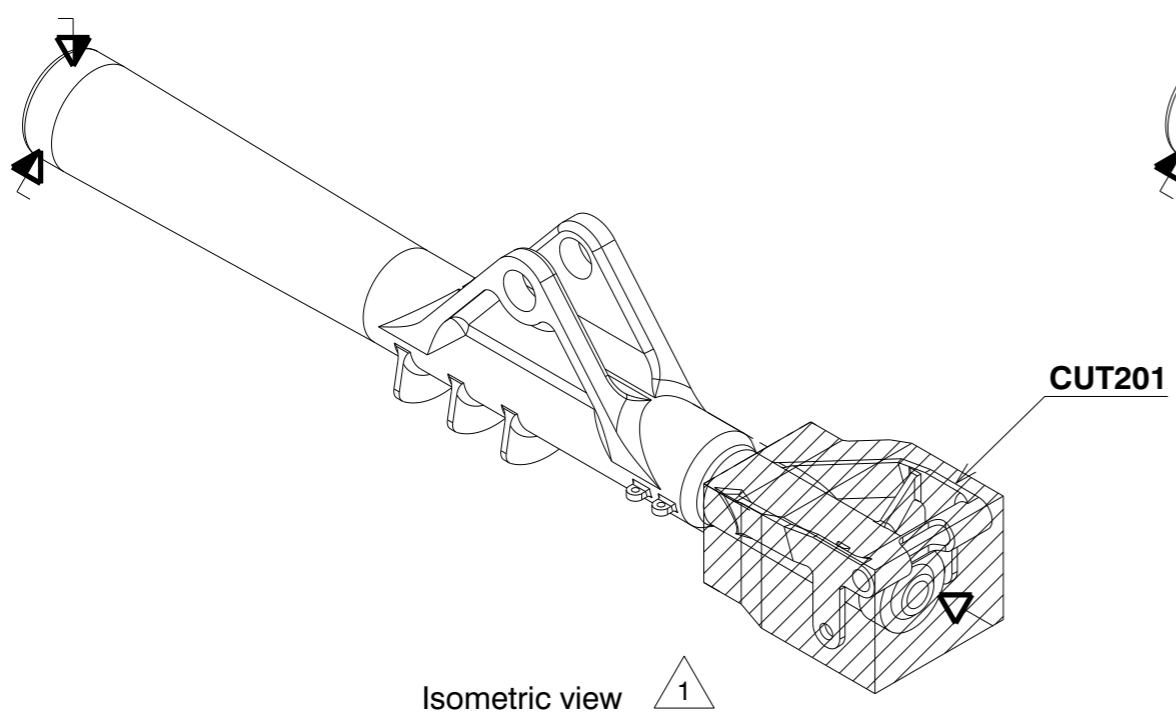

**TungMeister**





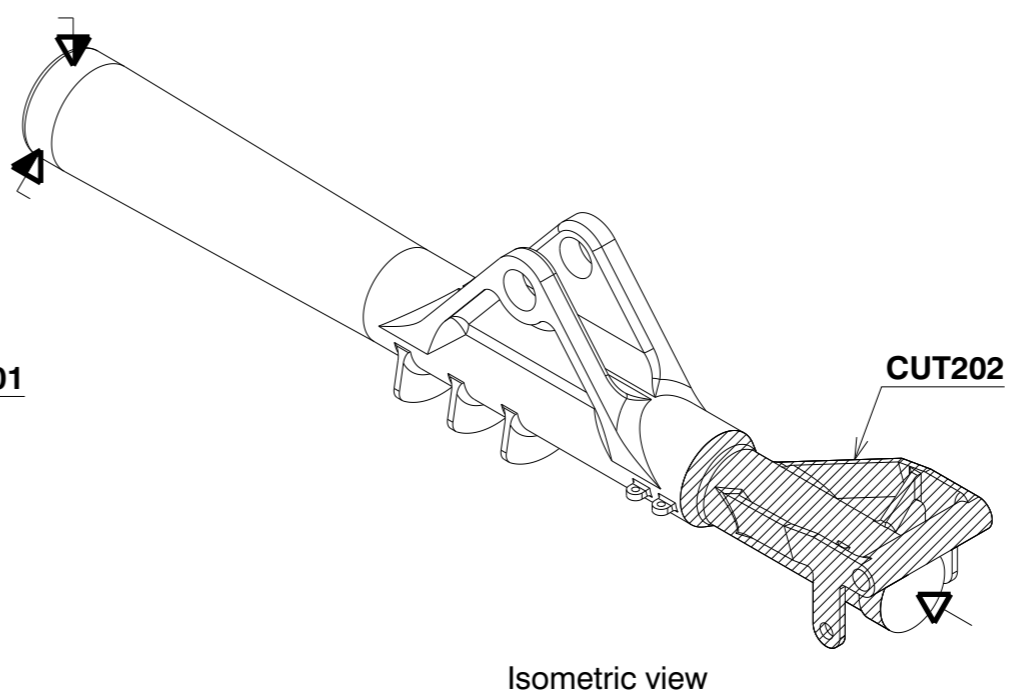

Isometric view 



Isometric view

**M/C : Out side Millng Rough / Finish**

Unspecified Tolerances	Draw	-.	-.	Customer: TUNGALOY	Japan	
Dim.s:	Design			Designation:		
Angles:	Check			LAYOUT OP200-LANDING GEAR		32448865-HC5
	Appr.			Process	Layout.	Page 1
	Scale	-		Concept		Of 1
	© 2019 Tungaloy Corporation - Copyrights Notice			-		Rev. No. 
				FL-40032524		Reg.No. 62312/1
						A3L

MODEL IN SCALE : Free TOOLS IN SCALE 1:3

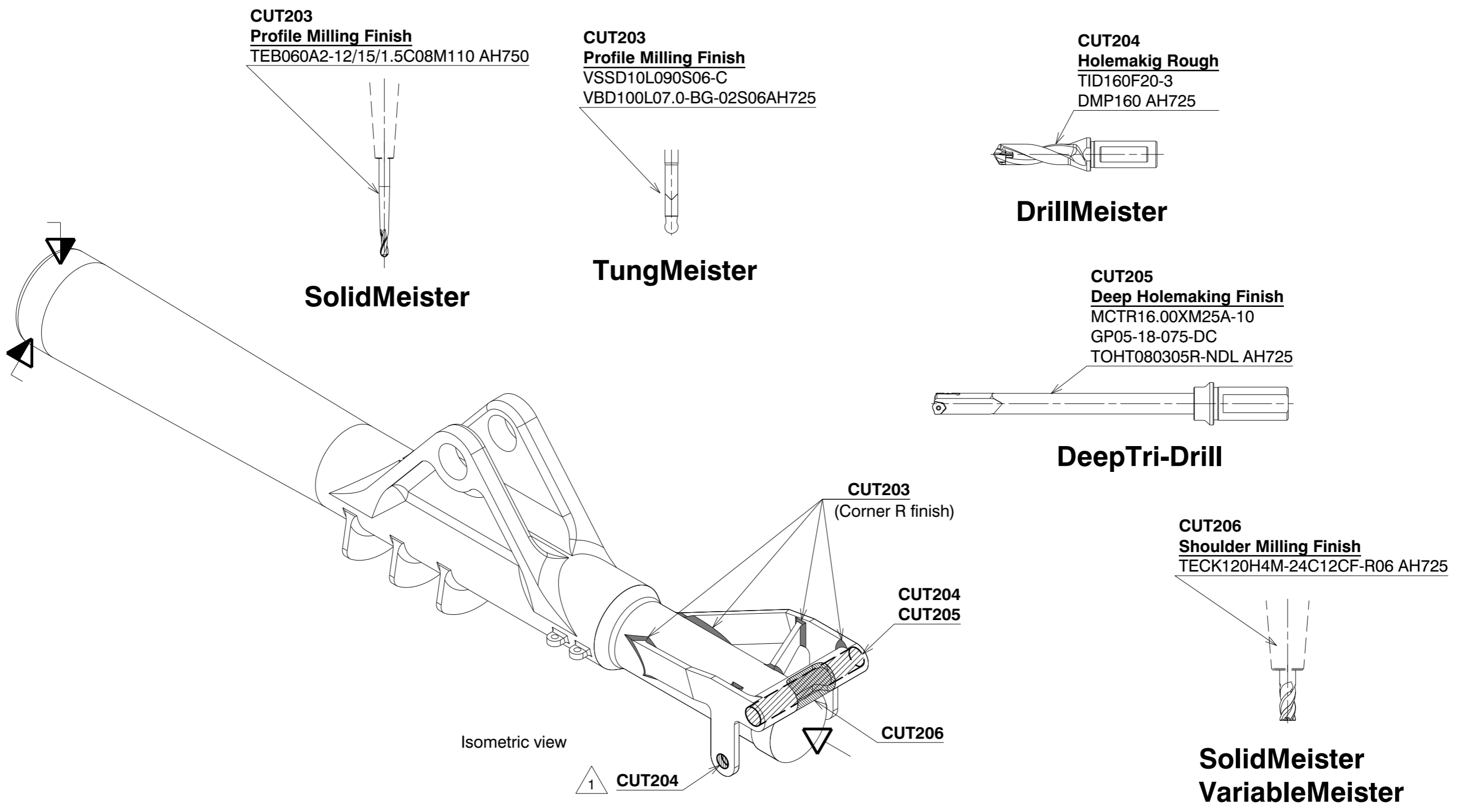

**M/C : Profile Milling Finish / Holemaking / Shoulder Milling**

Unspecified Tolerances	Draw	--	--	Customer: TUNGALOY	Japan	
Dim.s:	Design			Designation: LAYOUT OP200-LANDING GEAR		
Angles:	Check			Process	Layout.	Page 1
	Appr.			Concept		Of 1
	Scale	-		-		Rev. No. 1
	© 2019 Tungaloy Corporation - Copyrights Notice			FL-40032524		Reg.No. 62312/1
						A3L



MODEL IN SCALE : Free TOOLS IN SCALE 1:3

**CUT207**  
**Pre Holemaking Rough**  
 DSW051-020-06DE3 AH725

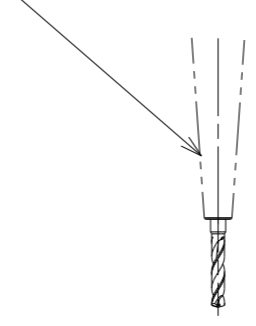

**SolidDrill**

**CUT208**  
**Unified Threading Finish**  
 MTEC06045C1220UN AH725

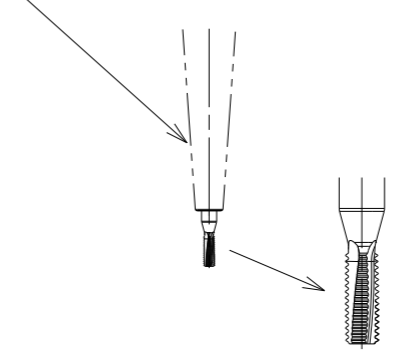

**ThreadMilling**

**CUT209**  
**Profile Milling Finish**  
 TEB030A2-06/08/3.0C06M70 AH725

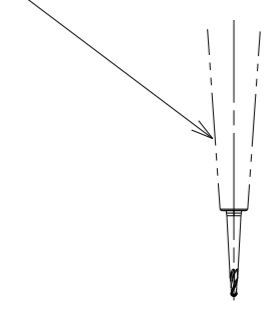

**SolidMeister**

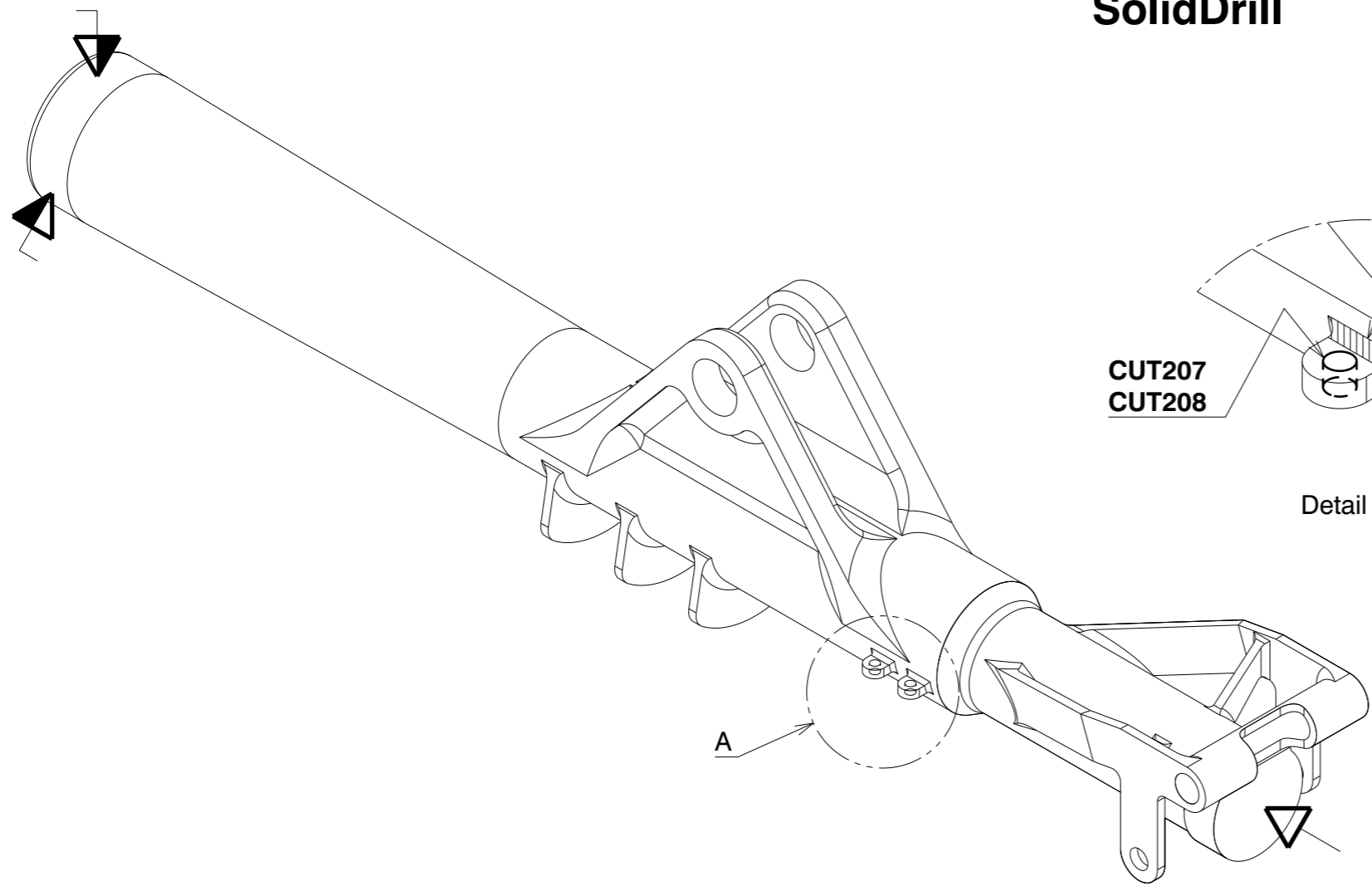

Isometric view

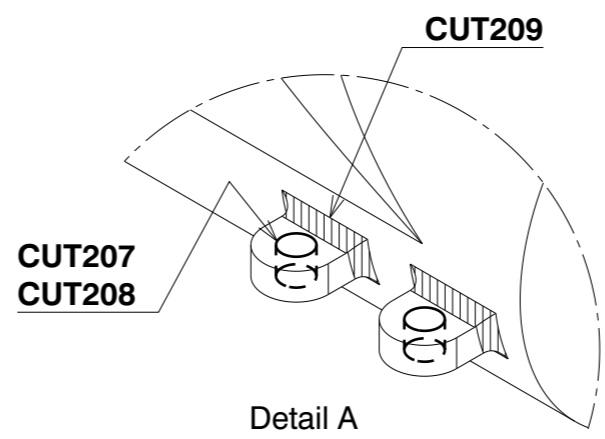

**M/C : Threading / Profile Milling Finish**

Unspecified Tolerances	Draw	-.	-.	Customer: TUNGALOY	Japan	
	Design			Designation: LAYOUT OP200-LANDING GEAR		
Dim.s: -.	Check			Process		Page 1 Rev. No. 0
	Appr.			Concept		Of 1
Angles: -.	Scale	-		Layout.		Reg.No. 62312/1
				-		A3L
				© 2019 Tungaloy Corporation - Copyrights Notice		FL-40032524